

Title	A concurrent power supply and data transmission protocol for 2D communication sensor system
Author(s)	Lim, Azman Osman; Oota, Toshifumi; Kado, Youiti; Shirazi, Mehdad N.; Zhang, Bing
Citation	2010 Seventh International Conference on Networked Sensing Systems (INSS): 85-88
Issue Date	2010-06
Type	Conference Paper
Text version	publisher
URL	<a href="http://hdl.handle.net/10119/10327">http://hdl.handle.net/10119/10327</a>
Rights	Copyright (C) 2010 IEEE. Reprinted from 2010 Seventh International Conference on Networked Sensing Systems (INSS), 2010, 85-88. This material is posted here with permission of the IEEE. Such permission of the IEEE does not in any way imply IEEE endorsement of any of JAIST's products or services. Internal or personal use of this material is permitted. However, permission to reprint/republish this material for advertising or promotional purposes or for creating new collective works for resale or redistribution must be obtained from the IEEE by writing to <a href="mailto:pubs-permissions@ieee.org">pubs-permissions@ieee.org</a> . By choosing to view this document, you agree to all provisions of the copyright laws protecting it.
Description	



# A Concurrent Power Supply and Data Transmission Protocol for 2D Communication Sensor System

Azman Osman Lim, *Member, IEEE*, Toshifumi Oota, *Nonmember, IEEE*, Youiti Kado, *Nonmember, IEEE*, Mehdad N. Shirazi, *Nonmember, IEEE*, and Bing Zhang, *Member, IEEE*

*Abstract*—The two-dimensional communication system (2DCS) is a novel technology that allows the surface physical as a communication medium for providing simultaneous power supply and data transmission to any device. However, how to carry out simultaneous power supply and data transmission in an efficient manner is still an open issue for 2DCS. In this paper, we propose a concurrent power supply and data transmission protocol based on the modifications of IEEE 802.15.4 MAC protocol standard, and then propose a generic rechargeable battery model by considering the features of 2DCS. Simulation results reveal that our proposed scheme highly improves the energy charging efficiency of 2DCS.

*Index Terms*—2D communication system, concurrent power supply and data transmission, generic rechargeable battery model

## I. INTRODUCTION

Convergence of home networks and the next generation Internet further brings Internet into a variety of application scenarios which provide users with a wide range of high demanding services. The two-dimensional communication system (2DCS) has a huge potential for realizing the aforementioned network convergence. This is because the novelty of 2DCS is invented in order to provide a high-speed end user Internet access technology at home. In 2DCS, radio waves are confined and propagated inside a special designed 2D sheet. A special coupler (hereinafter we call it connector) is used to transmit and receive the radio waves through the 2D sheet. Basically, 2DCS allows the 2D sheet to provide room-size communications and other services to devices that are placed on top of it. The devices may include sensors, laptops, PDAs, mobile phones, home appliances, and other types of device habitually placed on the surface. This new medium form of 2DCS is not just able to establish the high-speed data transmission between two devices, but it also can provide other services including power supply provision, high security, high accurate estimation of the device's location, and efficient spatial reuse.

A dearth of research has been published in relation to the surface as a medium for power and networking. For example, a 'networked surface' was proposed by Scott et al. [1] in October 1998 at the Laboratory for Communications Engineering, Cambridge University. The Networked Surface is primarily

aimed at connection of higher-end computational devices (e.g., handhelds and laptops) that are placed on top of the surface such as a table. On the other hand, Lifton and Paradiso [2] use the surface with pushpins and layered conductive sheets, where direct contact to the conductive layers in the board is used to obtain the power, whereas the networking is established via infrared. To envisage high-speed networking capabilities, Laerhoven et al. [3] propose that the conductive layer can be used as a bus network for pins. Instead of using pin-shaped connector, Sekitani et al. [4] have successfully manufactured a large-area power transmission sheet by using printing technologies. The position of electronic objects on the sheet can be contactlessly sensed by electromagnetic coupling using an organic transistor active matrix. The power is selectively fed to the objects by electromagnetic field using a plastic MEMS-switching matrix. The major disadvantage of this system is the issue of capacitive coupling. This is because it is difficult for people to put the receiver on the right position on top of the transmitter.

To tackle the mismatching problem on the connector, Yamahira et al. [5] introduce a simple 2DCS whereby a proximity connector touches the surface freely without restraint for power or networking. Meanwhile, Itai et al. [6] propose an electrode array for absorbing the power from 2D sheet in order to realize the simultaneous signal-power transmission at the device side. To our knowledge, no specific protocol scheme for enabling concurrent power supply and data transmission functions so far. The authors [7] were the first proposed the concurrent power supply and data transmission protocol for the 2DCS. This original idea becomes our focus in this paper to study the simple, efficient concurrent power supply and data transmission protocol for the 2DCS when a novel generic rechargeable battery is modeled. In other words, we can focus our study mainly on the energy charging efficiency for 2DCS when the proposed scheme is applied.

The rest of the paper is organized as follows. Section II describes briefly our proposed concurrent protocol in conjunction with the ZigBee protocol. Section III explains the generic rechargeable battery model, which is adopted in our simulation. Section IV presents the simulation settings, scenarios, and performance results. The last section concludes the paper.

## II. CONCURRENT POWER SUPPLY AND DATA TRANSMISSION PROTOCOL

The 2DCS is potentially used for sensing across a range of home applications, e.g., measuring the temperature at the

Manuscript received December 24, 2009; revised April 15, 2010.

A. O. Lim, T. Oota, Y. Kado, M. N. Shirazi, and B. Zhang are with the National Institute of Information Communications Technology (NICT), 2-2-2 Hikaridai, Seika-cho, Soraku-gun, Kyoto 619-0288, JAPAN (e-mail: {aolim, oota, kado, mahdad, zhang}@nict.go.jp).

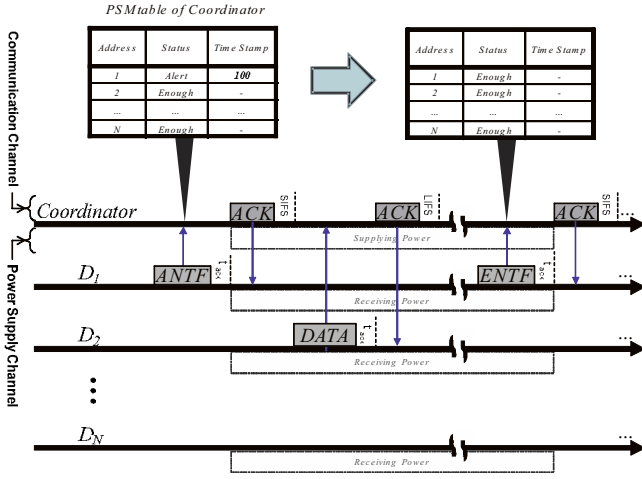

Fig. 1. Frame passing of ANTF and ENTF.

living room and uploading the measured data to the Internet. Most of the existing protocol for such networks is designed to efficiently deal with energy limited resources in order to maximize the network lifetime. To design the protocol that can support both power supply and data transmission features, we therefore propose the concurrent power supply and data transmission protocol, which is based on the IEEE 802.15.4 (ZigBee) protocol standard. One of the main reasons of choosing the ZigBee is that the protocol is simple to be modified for adding the power supply feature at the first preliminary stage of protocol implementation. More details on the proposed scheme can be found in [7]. In this paper, we will only briefly discuss the operation of the proposed scheme.

To support the power supply feature in the ZigBee protocol, an alert notification (ANTF) frame and an enough notification (ENTF) frame are proposed. These two frames follow the handshaking sequence of other control frames in the ZigBee protocol. When a device attempts to transmit the ANTF frame or the ENTF frame, it must first sense the channel in the contention access period interval. Upon transmitting the ANTF frame or the ENTF frame, the device waits for the ACK frame from the coordinator. When the device fails to receive the ACK frame, the device increases the contention window before it makes another attempt to transmit the failed frame. Figure 1 shows how the coordinator manages its power supply channel corresponding to the received ANTF and ENTF frames. At the initial operation, we assume that a coordinator contains a power supply management (PSM) table. Upon receiving the ANTF frame, the coordinator updates its PSM table with the alert entry of the sent device. Then, the coordinator supplies power continuously in the power supply channel. If the coordinator's PSM table contains none of the alert entries, then the coordinator shall stop supplying power.

### III. GENERIC RECHARGEABLE BATTERY MODEL

A battery model is necessary for a battery-driven system, such as sensor, mobile phone, etc. The battery model captures the characteristic of real-life rechargeable batteries, and can be used to predict system behavior under various conditions of

charge/discharge. The battery provides voltage and current for the components attached to the battery such as radio interfaces, central processing unit, memory blocks, sensing module, etc. The battery is a repository of electric charges, which loses its charge when an electrical current is taken off from it. In general, the unit of battery capacity is denoted as milli-ampere hour (mAh). One mAh is the electric charge transferred by a steady current of one milli-ampere for one hour. In this paper, we assume a generic rechargeable battery model. This model is based on battery capacity counting technique. The battery capacity counting technique accumulates exponentially according to time when the battery is charging and dissipates exponentially when the battery is discharging. Figure 2(a) shows the battery exponential charging characteristic. This model does not consider over-charging loss, charge/discharge efficiency, self-discharge loss, time durability, and cycle durability.

We model that the generic rechargeable battery model is equivalent to a resistor-capacitor circuit representation of rechargeable battery as shown in Fig. 2(b). In the electrical schematic, we simplify the circuit representation model from [8] into two basic components: internal resistance ( $R_i$ ) and effective capacitance ( $C_e$ ). We consider that  $\gamma$  denotes the charging rate with  $0 \leq \gamma \leq 1$ . Thus, the voltage of internal resistance and the voltage of capacitance is equivalent to the nominal voltage for charging the battery.

$$V_{R_i} + V_{C_e} = V_{nom} \quad (1)$$

$$\Rightarrow I_c R_i + \frac{Q}{C_e} = V_{nom} \quad (2)$$

We know  $Q = \gamma C_e V_{nom}$  and the battery charging current can be written as below:

$$I_c = (1 - \gamma) \frac{V_{nom}}{R_i} \quad (3)$$

Therefore, the battery charging capacity is given by

$$C_c = I_c T_c \quad (4)$$

where  $T_c$  is the charging time. Due to the internal resistance of battery, the battery encounters the capacity loss while it is charging. The battery charging capacity loss simply is given by

$$C_{loss} = (I_c)^2 R_i T_c \quad (5)$$

As we can see from Fig. 2(b), the input power from the rectenna can be expressed as below:

$$P_{in} = P_r - P_{dum p} \quad (6)$$

where  $P_{dum p}$  the dumped power from the rectenna, in which the battery cannot accept more power when the battery is getting to almost full. And we can obtain the received power of rectenna by the equation below:

$$P_r = P_S \frac{D}{2\pi d} \quad (7)$$

where  $P_S$  is the power supply level of the coordinator in Watt.  $D$  is the connector diameter in meter and  $d$  is the distance in between the connector and the coordinator. The equation (7) is

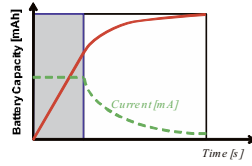

(a) Battery exponential charging characteristic

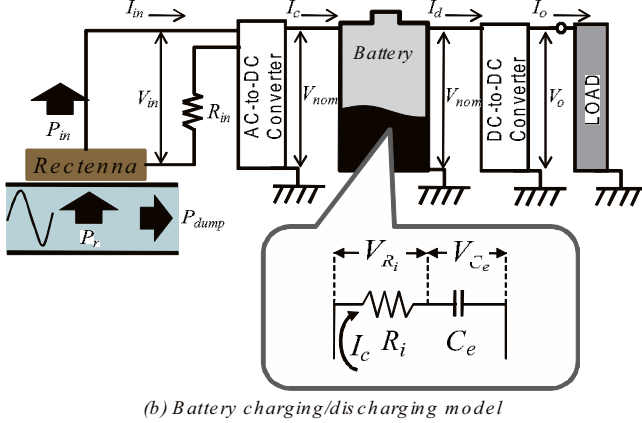

(b) Battery charging/discharging model

Fig. 2. A generic rechargeable battery model.

called as an angular pathloss model. Unlike wireless medium, the total received power in 2D medium can vary from the touched size of connector that puts on top of the 2D sheet. In other words, the total received power is proportional to the angle ( $\theta$ ) that is covered by the connector. We also consider that the total received power in the 2D medium is depending on the coordinator placement; the coordinator is at any point of 2D sheet, or at the side, or at the corner. In this paper, we do not consider the 2D sheet loss, shadowing effect, and reflect wave effect.

For evaluation purposes, we assume that  $n = \{1, 2, \dots, N\}$  is a set of sensors. We assume that each sensor is embedded with a rechargeable battery. Therefore, the energy charging of a sensor,  $n$ , from the coordinator is given by

$$E_c^n = V_{nom}^n C_c^n \quad (8)$$

And the energy charging loss of a sensor,  $n$ , is given by the equation below:

$$E_{loss}^n = V_{nom}^n C_{loss}^n \quad (9)$$

We define that the energy dumped of a sensor,  $n$ , is the waste of energy, simply the equation can be written as below:

$$E_{dump}^n = E_r^n \check{S} (E_c^n + E_{loss}^n) \quad (10)$$

We also obtain that the energy charging efficiency of 2DCS system can be expressed as follow:

$$E_{eff} = \frac{\sum_{n=1}^N E_c^n}{E_S} \quad (11)$$

where  $E_S$  is the total supplied energy from the coordinator.

## IV. PERFORMANCE EVALUATION

The simulation experiments are conducted through QualNet 4.5 simulator, and the simulation time is 24 hours. Two topologies are considered in the simulation. The coordinator in both topologies is placed at the bottom-left corner of 2D sheet area, which the size is  $3 \text{ m} \times 3 \text{ m}$ . The first topology is an arrangement with one sensor and the second topology is an arrangement with two sensors. In the second topology, the near-sensor and the far-sensor are placed at one meter and three meters, respectively away from the coordinator. In both topologies, the sensor is set to send data packets to the coordinator. For the traffic model, a constant bit rate traffic is assumed where the packets of 64-byte are sent at the interval of 0.983 seconds. This interval value is equivalent to the beacon period when the beacon order is 6. In order to avoid packet collision, the first data packet of first sensor is sent at 20 ms. Then, the first data packet of second sensor is sent at 40 ms. The evaluation parameters are described as below:

- **Energy Charging Loss ( $E_{loss}$ )** is defined as the total energy charging loss by all the sensors while the sensors' battery are charging.
- **Energy Dumped ( $E_{dump}$ )** is defined as the total energy waste by all the sensors when the sensor's battery are reluctant to be charged.
- **Energy Charging Efficiency ( $E_{eff}$ )** is defined as the total energy charging by all the sensors over the total energy supplied by the coordinator.

### A. Simulation Result and Discussion

Figure 3(a) shows the total energy charging varies with the power supplied level for one-sensor topology. For the case without the proposed scheme, the coordinator is supplying power from the beginning of simulation until the end of simulation. The total energy charging for the case without the proposed scheme is higher than the case with the proposed scheme. This is because the sensor keeps charging its battery all the times even though the battery capacity is full. As we can see from Fig. 3(b), the total energy supplied for the case without the proposed scheme and for the case with the proposed scheme is the same when the supplying power is small. If we increase the power supply, the total energy supplied for the case without the proposed scheme increases exponentially whereas the case with the proposed scheme maintains the fixed power supply level. As a result, 87.13 % improvement of supplying power for the case with the proposed scheme when the power supplied level is 33 dBm. In the viewpoint of energy charging efficiency as shown in Fig. 3(c), the energy charging efficiency is gradually decreased to about 0.05 % for the case without the proposed scheme when the power supplied level is 33 dBm. However, the energy charging efficiency is constantly maintained at 0.33 % for the case with the proposed scheme.

Figure 4(a) indicates that the energy charging loss increases as the power supplied level increases for two-sensor topology. Moreover, the energy charging loss of the case with the proposed scheme is higher than the case without the proposed scheme. This is because the case with the proposed scheme

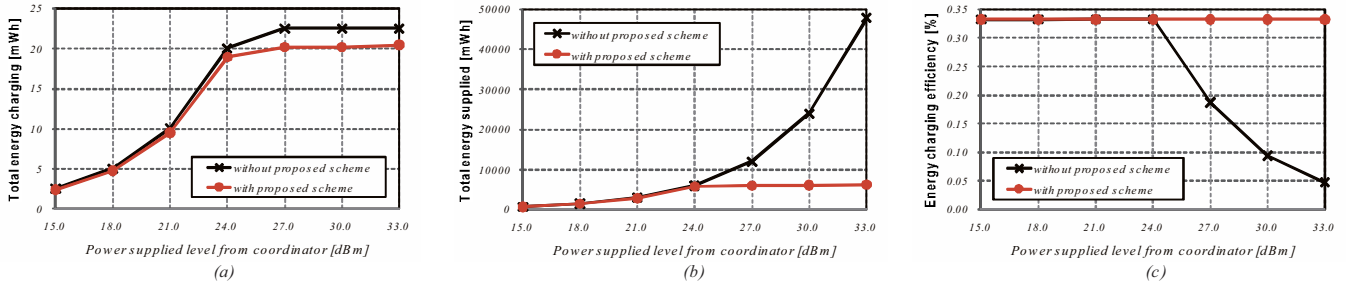

Fig. 3. Simulation results for one-sensor topology.

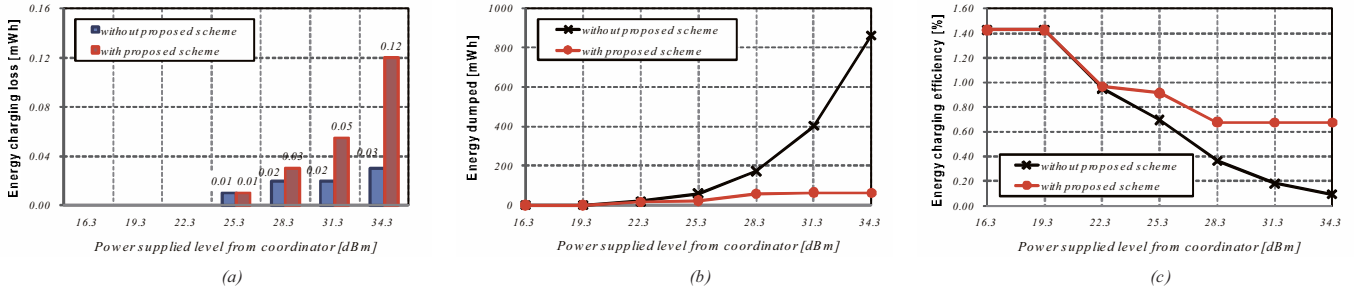

Fig. 4. Simulation results for two-sensor topology.

enables the power supply ON and OFF at the coordinator side by sending the frames of ANTF and ENTF, respectively depending on the battery capacity level. Since the energy charging loss is high when the battery capacity level is low, there is almost nothing about the energy loss for the case with the proposed scheme when we compare to the low energy dumped for the entire simulation. On the other hand, the case without the proposed scheme faces the high energy dumped even though the energy loss is low. Figure 4(b) indicates that the energy dumped. When the high energy dumped occurs, the battery cannot accept more energy when the battery level is almost full. In other words, high power supply can make the energy dumped increase severely. Therefore, our proposed scheme solves this problem by stopping the power supply when the battery is sufficiently charged. Figure 4(c) shows that the energy charging efficiency decreases as the supplied power level increases. However, we can observe that the energy charging efficiency for the case with the proposed scheme is better than the case without the proposed scheme. This is because the energy supplied for the case with the proposed scheme is low when the energy dumped is low, in which this leads to the high energy charging efficiency. When the power supplied level is 34.3 dBm, the energy charging efficiency is about 0.67% for the case with the proposed scheme. However, the energy charging efficiency is about 0.09% for the case without the proposed scheme. We summarize that the case with the proposed scheme can significantly improve the energy charging efficiency for the overall system of 2DCS.

## V. CONCLUDING REMARKS

We proposed the feasible concurrent power supply and data transmission protocol in cooperation with the ZigBee protocol, which allows sensor to charge its own battery corresponding

to the battery status without disturbing the data transmission among other sensors. By taking into account the generic rechargeable battery model, we examined the performance of the proposed scheme. Simulation results reveal that the proposed scheme improves the energy charging efficiency and reduces the energy dumped. As our future works, we will further evaluate the performance of the proposed scheme when we consider other factors like the different propagation model with shadowing and reflection effects.

## REFERENCES

- [1] J. Scott, F. Hoffmann, M. Adlaseet, G. Mappt, and A. Hopper, "Networked surfaces: A new concept in mobile networking," in *Proc. IEEE Workshop on Mobile Computing Systems and Applications (WMCSA)*, pp.11–18, 2000.
- [2] J. Lifton and J. Paradiso, "Pushpin computing system overview: A platform for distributed, embedded, ubiquitous sensor networks," in *Proc. Pervasive Comp., Lecture Notes in Computer Science (LNCS)*, vol.2414, pp.139–151, 2002.
- [3] K.V. Laerhoven, N. Villar, A. Schmidt, and H.W. Gellersen, "Pin & play: The surface as network medium," *IEEE Commun. Mag.*, vol.41, no.4, pp.90–95, 2003.
- [4] T. Sekitani, M. Takamiya, Y. Noguchi, S. Nakano, Y. Kato, K. Hizu, H. Kawaguchi, T. Sakurai, and T. Someya, "A large-area flexible wireless power transmission sheet using printed plastic MEMS switches and organic field-effect transistors," in *Proc. IEEE Int. Electron Devices Meeting (IEDM) Conf.*, pp. 287–290, 2006.
- [5] N. Yamahira, Y. Makino, H. Itai, and H. Shinoda, "Proximity connection in two-dimensional signal transmission," in *Proc. SICE-ICASE Int. Joint Conf.*, pp.2735–2740, 2006.
- [6] H. Itai, B. Zhang, and H. Shinoda, "Method of simultaneous signal-power transmission using surface microwave," in *IEICE Technical Report on Ubiquitous and Sensor Networks (USN)*, vol.107, no.53, pp. 115–118, 2007.
- [7] A.O. Lim, T. Oota, and B. Zhang, "Adaptive power supply scheme and performance evaluation for 2-dimensional communication system," in *IEICE Technical Report on Ubiquitous and Sensor Networks (USN)*, vol.108, no.252, pp.27–32, 2008.
- [8] L. Gao, S. Liu, and R.A. Dougal, "Dynamic lithium-ion battery model for system simulation," in *IEEE Trans. on Components and Packaging Technologies*, vol.25, no.3, pp.495–505, 2002.