

Title	Energy efficient thermal comfort service controller in home network environment
Author(s)	Luu, Hai Quoc
Citation	
Issue Date	2012-09
Type	Thesis or Dissertation
Text version	author
URL	<a href="http://hdl.handle.net/10119/10770">http://hdl.handle.net/10119/10770</a>
Rights	
Description	Supervisor: Tan Yasuo, 情報科学研究科, 修士

# Energy efficient thermal comfort service controller in home network environment

By Luu Hai Quoc

A thesis submitted to  
School of Information Science,  
Japan Advanced Institute of Science and Technology,  
in partial fulfillment of the requirements  
for the degree of  
Master of Information Science  
Graduate Program in Information Science

Written under the direction of  
Professor Yasuo Tan

September, 2012

# Energy efficient thermal comfort service controller in home network environment

By Luu Hai Quoc (1010216)

A thesis submitted to  
School of Information Science,  
Japan Advanced Institute of Science and Technology,  
in partial fulfillment of the requirements  
for the degree of  
Master of Information Science  
Graduate Program in Information Science

Written under the direction of  
Professor Yasuo Tan

and approved by  
Professor Yasuo Tan  
Associate Professor Lim Azman Osman  
Professor Yoichi Shinoda

August, 2012 (Submitted)

## Contents

Chapter 1 Introduction .....	1
1.1 Home network system and service.....	1
1.2 Objective .....	1
1.3 Structure of this document .....	2
Chapter 2 Background research.....	3
2.1 Sensor network.....	3
2.2 Home service network.....	4
2.3 Related work .....	5
2.4 Proposed methodology and system .....	5
2.4.1 Methodology.....	5
2.4.2 Proposed system .....	6
Chapter 3 Thermal comfort.....	7
3.1 Thermal comfort factor .....	7
3.1.1 Relative humidity .....	7
3.1.2 Air velocity.....	7
3.2 Thermal comfort calculator model.....	7
3.2.1 WBGT (Wet Bulb Globe Temperature) .....	8
3.2.2 Apparent Temperature of Steadman model.....	8
3.2.3 WBGT .....	9
3.2.4 Not comfort Index (NCI).....	9
3.2.5 Sensible temperature: net effective temperature (NET).....	9
Chapter 4 System architecture and implementation .....	11
4.1 System overview .....	11
4.2 Sensor Logger .....	12

4.3 Device client controller .....	15
4.4 Air conditioner controller .....	16
4.5 Thermal comfort controller .....	17
4.5.1 Controller algorithm .....	18
4.5.2 Client socket module .....	20
4.5.3 Device manager module .....	20
4.5.4 Environment manager.....	21
4.5.5 NCI NET Logger .....	24
Chapter 5 Experiment and evaluation.....	26
5.1 Experiment method .....	26
5.1. 1 Experiment environment .....	26
5.1.2 Sensor and device .....	27
5.2 Evaluation method.....	30
5.3 Result.....	32
5.4 Conclusion – Future work.....	40
Bibliography .....	42
Appendix A : Home device command configuration file.....	43
Appendix B : User manual for TCSC system installation .....	44

# Chapter 1

## Introduction

### 1.1 Home network system and service

As the development of High speed Internet Access in Japan such as ADSL or FTTH in Japan, it provides the required infrastructure for the trend of Home Network System (referenced as HNS). For example, one of the popular trend in HNS is home security and home automation system that consists the combination of many home appliance and sensor network. Home Network Service access the home resource by the home gateway, provides the automation controller to the user such as home appliance remote control. Recently, the applications of sensor network in home environment become more variety and give more solution for the smart home service. Sensing data from the sensor network give more information for the Home Network Service about the environment for make decision to the home resource. The trend of giving more better method for managing the home resource and combined them to give an functions to the end user is the main point of Home Network Service .

### 1.2 Objective

The aim of this research is to build a Home Network Service that called thermal comfort controller service. By the sensing data of surrounding climate such as temperature, humidity, wind, rain, it give the operations to the home appliances to achieve the inside thermal comfort, also striving to improve energy consumption. Moreover, for saving the energy consumption, the controller try to use the outside air, and the air circulation inside room to achieve the human comfort, without use a lot of energy consumption of air conditioner. For example, in summer, the air conditioner is usually turned on to create the inside comfort by keeping the temperature room in a suitable temperature. At summer midnight about 3a.m to 6a.m when the outside air temperature is around 25 Cencius degree, but people also use the air conditioner until they wake up in the morning. Hence, at that time when the air temperature is very comfort, we can save the energy by turning off the air conditioner, open window to get the air go inside, and use fan instead of cooling system.

In some related research, the method of controlling the air conditioning system in suitable operation for increasing comfort and decreasing unnecessary energy use based on use the information of surrounding environment. For the better energy efficient of a human comfort system, another approach is proposed by taking the advantages of outdoor air and try to use another human-comfort-related-devices, as less as possible using the air conditioner.

Thermal comfort is the state of humans that expresses satisfaction with the surrounding environment, includes a lot of factors such as air temperature, humidity, wind, meant radiant temperature. A cooling system is just balance the two factors of air temperature and humidity to achieve the human comfort and consume a lot of energy. In this research we will research

strategies to achieve thermal comfort by balancing all the above thermal comfort factors, propose a thermal comfort system for the users under a variety of scenarios and different home configurations but and less using the air conditioner while making utility of outdoor air for better energy efficient.

### **1.3 Structure of this document**

Chapter 1 introduce the trend of home network system and objective of this research. Chapter 2 give some background knowledge about sensor network and home service network. The definition, calculator model of thermal comfort; the model used in this research is presented in chapter 3. The detail of experiment and implementation of thermal comfort controller system is put in the chapter 4.

In Chapter 5 will give the experiment and evaluation methodology, introduce about the experiment environment. Finally, the problem of the implemented system also be presented in chapter 5.

# Chapter 2

## Background research

### 2.1 Sensor network

A sensor network consists of spatially distributed autonomous sensors to *monitor* physical or environmental conditions, such as temperature, sound, pressure, etc. and to cooperatively pass their data through the network to a main location. Sensor network consists a lot of different kind of sensor such as temperature, humidity, vehicular movement, lightning condition, noise levels, etc. Sensor nodes can be used for continuous sensing, event detection, event ID, location sensing, and local control of actuators. Sensor network has many applications in a wide range of field such as military, health care, smart home.

Sensor network in home applications field, have two mains trend is home automation and smart environment.

- In home automation, smart sensor nodes and actuators can be buried in appliances, such as vacuum cleaners, micro-wave ovens. These sensor nodes inside the domestic devices can interact with each other and with the external network via the Internet. They allow end users to manage home devices locally and remotely more easily.
- In smart environment, the sensor network can be embedded into the Home Network Service and give the monitoring data about the home environment to the service, and new hardware technologies, networking solutions, and middleware services have to be developed. Sensor nodes can be integrated with existing embedded devices to become self-organizing, self regulated through the decision of Home Network Service. One specific scenarios is described in Fig. 1, it consists of Smart Home Management Server, Home Server and one or more sensors and actuators. The home server gathers sensing data via its sensor network, becomes aware of environmental situations by communicating the sensing data gathered with smart home management servers that are in the remote system. The sensors are used for getting environmental data, monitoring situations and the actuators are for controlling devices to provide services to user without any control of user.



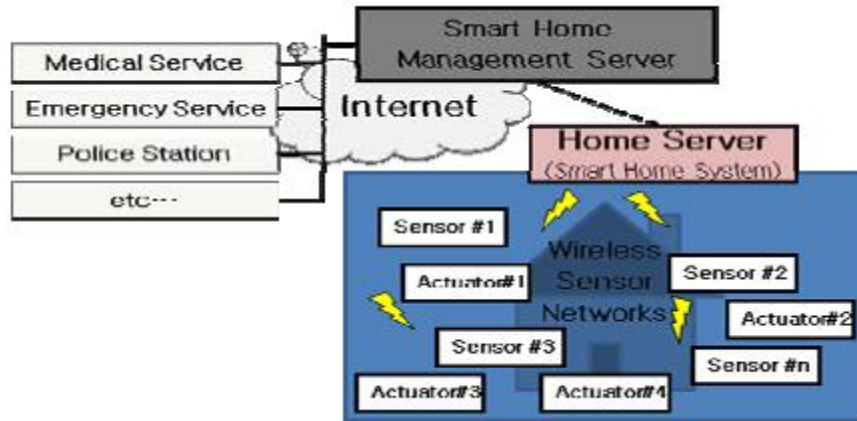

Figure 2.1: Sensor network in smart home applications

## 2.2 Home service network

Home information network is mainly composed of digital electrical home appliances, network that connects these electrical home appliances, home gateway that offers interconnection among home information network and outside network and controls and manages home information network, etc. Its interconnection technology and standard include physics layers access technology, high rise interconnection technology, and management and control technology. Among them, physics layer access technology mainly includes HAVI (Home Audio/Video Interoperability) in audio frequency and video apparatus, UPnP (Universal Plug and Play) [2] that is applied to home information network proposed by Microsoft Company, middleware technology of home information network proposed by SUN and an end-to-end solution, OSGi (Open Services Gateway Initiative) that is from remote service provider to local apparatus, etc.

Home gateway is an important factor in home information network, which is not only responsible for collecting state of information appliances and communication with customer's host computer, but also preventing home information network from being visited by illegal user. Home gateway mainly has such functions as security, Traffic control, firewall, QoS and information gathering of information appliances state, etc.

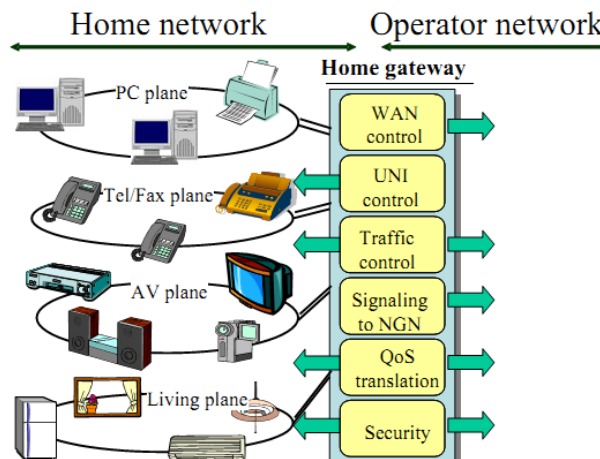

Figure 2.2: Home network and home gateway

## 2.3 Related work

In some related research, the method of controlling the air conditioning system in suitable operation for increasing comfort and decreasing unnecessary energy use based on make utility of the outdoor air is proposed and give some results in energy efficient [1,2]. In [2], multi-point of Zigbee sensor is built to measure the data of temperature and humidity in the surrounding environment, and to increase comfort and to decrease unnecessary energy waste from the air conditioner. Fuzzy rule is applied to calculate the membership grade, and control air conditioning system according to the most suitable operation speed of the environment.

In this research, for the better energy efficient of a human comfort system, another approach is proposed by taking the advantages of outdoor air and try to use the another human-comfort-related-devices, create the air circulation to give the human comfort, and as less as possible using the air conditioner.

## 2.4 Proposed methodology and system

### 2.4.1 Methodology

As introduced in section 1.2, the target of this research is built a system that obtained the home inside human thermal comfort and achieve good energy efficiency. The popular cooling system makes people feel comfortable when set the temperature at about 24<sup>0</sup>C, however it consumes a lot of energy. By the research of Tokyo Environmental agency in [11], if air conditioner ups 1<sup>0</sup>C, the system can save 10% consumption energy. The solution of energy efficiency of this system is try to get the outdoor air inside if it acceptable and gives comfort state to human. The current of outdoor air is updated to the system continuously, supports system to understand clearly the surrounding environment status. For example, if the air temperature is 24<sup>0</sup>C, relative humidity is 60%, people will feel comfortable with this condition. At that time, system will get the outdoor air into inside and use the fan for create the inside air circulation. How this action affects to the inside air, how it change the inside conditions such as air temperature and humidity is also observed. The next operation of system is depended on the current status of inside comfort and outdoor air. Therefore, the system reads the status of inside door continuously to know whether inside air achieves thermal comfort or not, the information of outdoor air also get updated rapidly. By this way, the comfort outdoor air is used while the using of fan create and the inside air circulation, and especially, try to set the temperature of air conditioner in high temperature brings the result in saving wasteful energy.

The strategy for the system to achieve the human comfort with the less using of air conditioner is consider deeply in this research. With the cooling system, it creates a cool air

circulation, and bring the comfortable feeling for human. However, the human comfort is controlled by a lot of factors, the thing to find out the effect of these factor to human comfort and discover a model to take account all factors to one index for measuring the human comfort is important. This problem is related a definition call thermal comfort, the analysis and strategy to get the thermal comfort is explained more detail in next chapter. In sum, this system is a kind of intelligent home service that take advantage of outdoor air and gives the human comfort by control a lot of climate factor affect directly to human instead of the using of cooling system.

### **2.4.2 Proposed system**

The proposed system is called thermal comfort controller service (from now called by TCSC). For understanding the outside and inside environment conditions, the temperature, humidity, wind and rain factor will be observed by the sensor network. Sensor network takes an important role by catching the environment context, gives the “smart knowledge” to system for set up the home device configuration as an intelligent home service. The more correctness of sensor network is, the more system understands about the surrounding air and inside comfort. By the communication with the sensor network, the system will know the current outside temperature, air, wind speed, whether it rains or not. Then analysis the information to know if the current outdoor air is good or not, the level of inside home comfort. After that, give the suitable operation to home device (window, curtain, air conditioner). The effect of control action to the inside comfort then be feed back by observing the inside condition by the sensor network, when the inside condition is changed it will be carefully observed and notify to our system for the next operation.

Moreover, the home device controller of variety devices of window, curtain, air conditioner also are implemented. These controller is the middleware of our TCSC, handling the request from TCSC and give the correct operation to home device. The main TCSC and sensor network server, home device controllers can be distributed on different system, because the components of entire system contact each other and can be accessed by Internet. This point gives the advantage of the real current situation when almost of information systems such as AV system, climate system, sensor system, etc is departed from each other and manage by themselves. In addition, with this kind of implementation, the system can be easily expanded, integrate other systems such as Image system for monitoring the action of home system.

# Chapter 3

## Thermal comfort

Thermal comfort is a term defined the state of mind in humans that expresses satisfaction with the surrounding environment. Thermal comfort is affected by air temperature, relative humidity, air velocity and radiation.

### 3.1 Thermal comfort factor

#### 3.1.1 Relative humidity

Relative humidity is the ratio of the current absolute humidity to the highest possible absolute humidity (which depends on the current air temperature). we feel much hotter than the actual temperature when the relative humidity is high. If the relative humidity is low, we can feel much cooler than the actual temperature because our sweat evaporates easily, cooling us off. In high humidity (higher than 85%) environment, human feels not very comfort. People tend to feel most comfortable at a relative humidity of about 25-65%, best in 45-50% percent.

#### 3.1.2 Air velocity

Air velocity is an important factor in thermal comfort because people are sensitive to it. Moving air in warm or humid conditions can increase heat loss through convection without any change in air temperature. Small air movement in cool or cold environments may be perceived as draught. If the air temperature is less than skin temperature it will significantly increase convective heat loss.

Wind blows also make the human sensible temperature decrease, feels cold (wind chill). Sensible temperature decreases when has wind. For example, when the air temperature is 25°C and relative humidity is 50%, if the wind speed is 0.5 m/s the sensible temperature is 24°C.

### 3.2 Thermal comfort calculator model

As mentioned in 3.1 section, human sensible temperature is consisted a lot of factor such as air temperature, wind, relative humidity. Usually, in daily life, we valuate about the hot or cool weather by the air temperature. However, combining all thermal comfort factors become one index for evaluating human thermal stress is researched and applied to the climate science by some developed country. To provide health-related weather services to the general public, many weather centers around the globe have developed various kinds of operational system for alerting the public to the danger of extreme weather conditions. Among of a lot of thermal

comfort calculating method, there are some outstanding method such as Wet Bulb Globe Temperature (WBGT), Apparent Temperature Heat Index and Apparent Temperature Wind Chill of Steadman model. More detail of these methodologies will be shown in next section.

### 3.2.1 WBGT (Wet Bulb Globe Temperature)

The index combined temperature, humidity, radiation and wind into a single value which could be used for assessment. the dry and wet bulb temperatures, radiation and air movement into a single heat index that is best suited to practical use in the field by personnel unskilled in psychrometry. It is determined from readings of the natural wet bulb temperature ( $t_w$ ), the black globe temperature ( $t_{bg}$ ), and shade air temperature ( $t_a$ ).

#### Formula

- For indoor environments (infra red radiation only)

$$WB-GT = 0.7t_w + 0.3t_{bg}$$

- For outdoor environments (solar radiation)

$$WB-GT = 0.7 t_w + 0.3 (a \times 0.95 (t_{bg} - t_a) + t_a)$$

where

$a$  = absorptivity of clothing for total solar radiation

0.95 = absorptivity of black globe

Globe temperature is measured by the *black globe thermometer*, which usually consists of a 150 mm (6 inch) black globe with a thermometer located at the centre.



Figure 3.1: black globe thermometer

### 3.2.2 Apparent Temperature of Steadman model

AT Steadman Model is a model that proposed by R.G Steadman for take accounting the apparent temperature index. The Steadman Appararen Temperature formula (Steadman, 1984) to measure the net heat loss of a healthy adult with an appropriate amount of outdoor clothing in winter. The model consists of a typical human walking at 1.4m/s, generating heat of 177W for each square metre on total body surface (177W/m<sup>2</sup>). The Thickness of clothing needed to equate heat loss to heat production (heat loss through the skin ) in steady-state conditions ,has one-to-

one correspondence to apparent temperature. By curve fitting the climate data in Australia, below simple computing formulas are obtained that included temperature, vapor pressure, wind and solar radiation factors.

<ul style="list-style-type: none"> <li>• Indoor</li> </ul> $AT_p = 0.89 T_a + 3.82 P_a - 2.56$
<ul style="list-style-type: none"> <li>• Shade</li> </ul> $AT_{pv} = T_a + 3.30 P_a - 0.70 v_{10} - 4.00$
<ul style="list-style-type: none"> <li>• In sun</li> </ul> $AT_{pvg} = T_a + 3.48 P_a - 0.70 v_{10} + 0.70 Q_g / (v_{10} + 10) - 4.25$

Where

Atp: Apparent Temperature with humidity applies

Atpv: Apparent Temperature with humidity and wind applies

Atpvg: Apparent Temperature with humidity, wind and extra radiation applies

$v_{10}$ : wind speed

$Q_g$ : heat transfer rate per unit area of body surface

### 3.2.3 WBGT

In the WBGT methodology, the black globe thermometer is required, while the Apparent Temperature of Steadman model is appropriate to Australia climate which is a dry temperature, low humidity climate country, has big different with Japan climate. Therefore, two above methodologies are not suitable with my research. Following, two others methodologies that are embedded in our system will be shown.

The indoor thermal comfort will be evaluated through two index: the non-comfort index (NCI) and sensible temperature (NET).

### 3.2.4 Not comfort Index (NCI)

NCI is the index combined from two factors air temperature and relative humidity, is used as a measurement of human comfort. The bigger the NCI is, the more discomfort people feels. Human feel comfort if NCI is about 60-70, and not comfort with the NCI higher than 80.

$$NCI = 0.81T + 0.01RH(0.99T - 14.3) + 46.3$$

### 3.2.5 Sensible temperature: net effective temperature (NET)

For measuring the thermal stress level, a methodologies is proposed by P.W. Li in [2]. This study is to explore the methodologies available, to adopt an operational index suitable to Hong Kong, and currently used by the Hong Kong 's climate bureau. This is the improved formulas from the effective temperature formula that is proposed by Missenard in 1937. NET formula calculates the sensible temperature by three factors: air temperature, humidity and wind speed . The resulting formula for NET is:

$$NET = 37 - \frac{37 - T}{0.68 - 0.001RH + 1 / (1.76 + 1.4v^{0.75})} - 0.29T(1 - 0.01RH)$$

where T is the ambient temperature (in °C), v the wind speed (in m /s) and RH the relative humidity (in %).

The advantages of using NET are:

- It is applicable in both hot and cold situations. It is relatively simple to compute and easy to interpret.
- It displays similar sensitivity as 'wind-chill' : NET decrease when wind speed grows bigger
- It is consistent with common human perception:
- In hot weather, NET increases as temperature and/or RH increases, but decreases with increasing winds;
- In cold weather, NET decreases with temperature, and with increasing RH and winds.

# Chapter 4

## System architecture and implementation

The thermal comfort service controller is a home network service in smart environment. It gets the outside /inside temperature and humidity, process the operation of air conditioner, window, curtain, fan suitably try to using the outdoor air if it is acceptable with the aim to get the thermal comfort in home environment and good energy efficient. The input/output of the system is shown in Figure 4. Base on the condition of the surrounding environment, the serice controller make the decision for the home devices: such as open/close window, set the suitable temperature of the cooling.

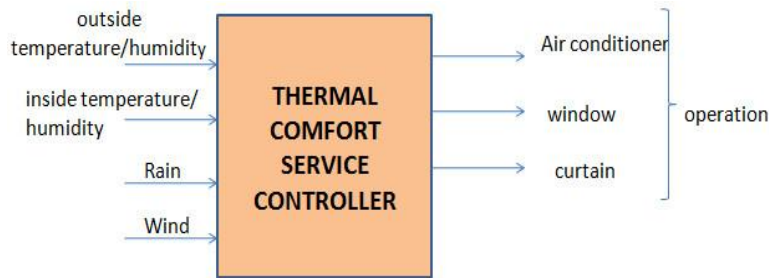

Figure 4.1: system overview with input and output

### 4.1 System overview

Figure 5 presents the system architecture overview. The main controller (thermal comfort service controller) get the context of the surrounding environment (air temperature, humidity, etc) from the sensor Logger modules, and give the command to the Device client if it want to operate the window and curtain, or send the command to Air conditioner controller if want to access the air conditioner. The request from the TCSC to window or curtain, at first is passed to Device Client, go to the Message Handling Server. At that step, base on the destination device, Message Handling Server will send operation request to Windowd modules for controlling windows or to Curtaind modules for requesting to curtain.



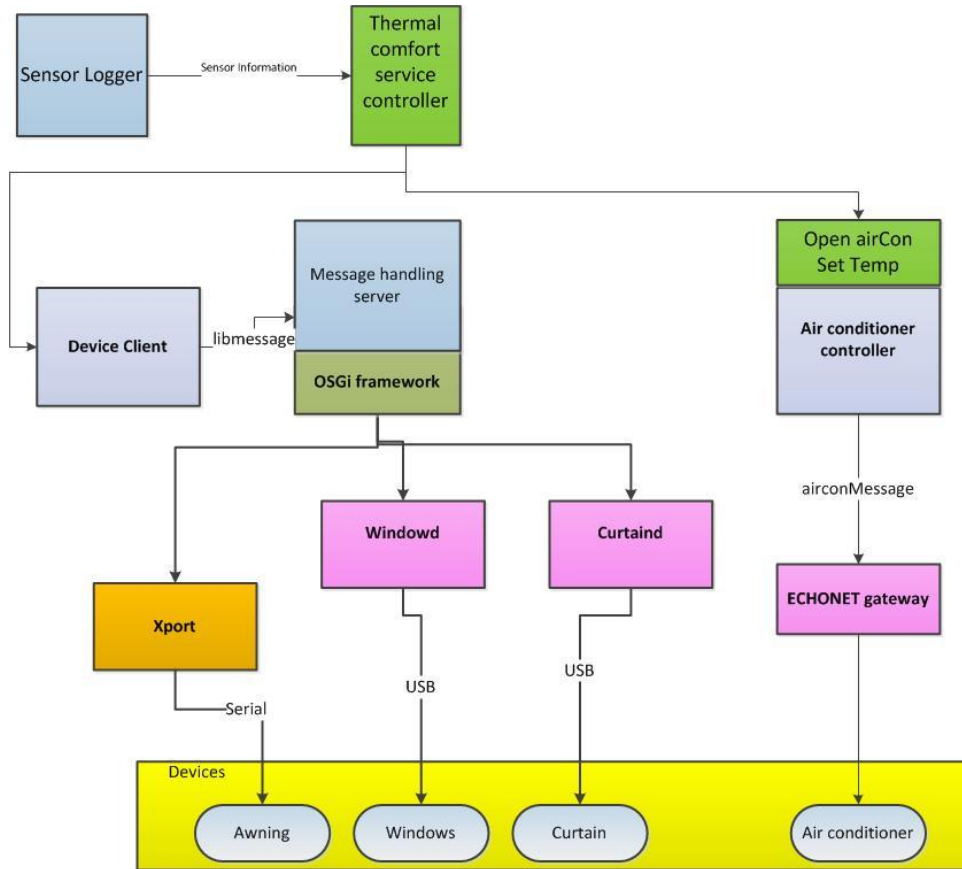

Figure 4.2: system software overview

## 4.2 Sensor Logger

Sensor Logger is to monitor the sensor information, get data of temperature/humidity, wind, rain into the record logger file, and send the block of data information to TCSC if it received the inquiry. It consists sensor data Logger and sensor data server modules. The sensor data Logger is communicated directly with the sensor network, get the information and put it in the logger file, while the sensor data server handles the request inquiry from the TCSC.

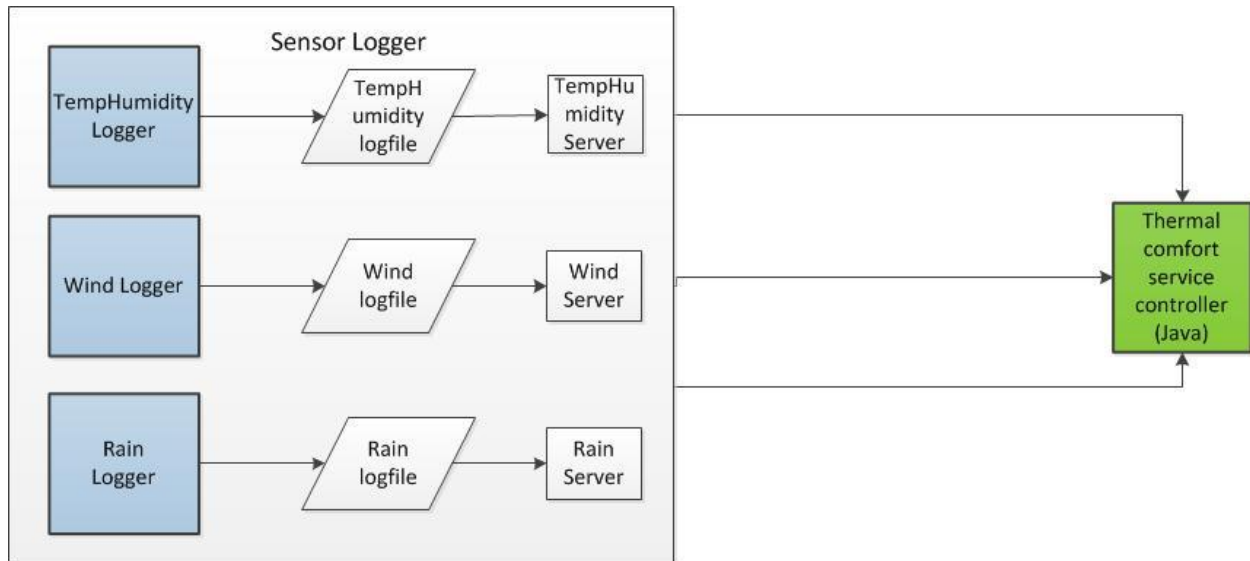

Figure 4.3: sensor logger structure

Sensor data log file includes the sensor information such as ID, and related-properties such as the temperature, humidity, or wind speed. The detail of these Sensor data log file is presented in below figures.

- ❖ temperature Humidity log file
  - first column: time
  - second column : sensor ID
  - third column: Temperature
  - fourth column: Humidity
- ❖ wind log file
  - first column: time
  - second column : wind speed
- ❖ rain log file
  - first column: time
  - second column : rain detection status

Time	Sensor ID	Temperature	Humidity
2012/08/06 00:00:00	8005	29.32	75.2,22,3,3
2012/08/06 00:00:03	8001	28.56	77.7,22,3,3
2012/08/06 00:00:05	9003	28.88	68.93,22,3,1
2012/08/06 00:00:16	10004	28.8	80.13,98,3,3
2012/08/06 00:00:16	9005	29.2	67.59,20,3,1
2012/08/06 00:00:18	10007	29.2	72.3,78,3,1
2012/08/06 00:00:18	8003	28.8	76.46,17,2,3
2012/08/06 00:00:20	10003	26.36	87.0,20,3,2
2012/08/06 00:00:30	8005	29.28	74.66,24,3,3
2012/08/06 00:00:33	8001	28.56	77.7,20,3,3
2012/08/06 00:00:35	9003	28.88	68.93,22,3,1
2012/08/06 00:00:46	9005	29.2	67.59,20,3,1
2012/08/06 00:00:46	10004	28.76	80.13,98,3,3
2012/08/06 00:00:48	10007	29.24	72.3,78,3,1
2012/08/06 00:00:49	8003	28.84	76.46,17,2,3
2012/08/06 00:00:50	10003	26.36	86.91,20,3,2
2012/08/06 00:01:01	8005	29.32	75.2,22,3,3
2012/08/06 00:01:03	8001	28.56	77.7,24,3,3
2012/08/06 00:01:05	9003	28.88	68.93,22,3,1
2012/08/06 00:01:16	9005	29.16	67.59,20,3,1
2012/08/06 00:01:16	10004	28.72	80.13,92,3,3
2012/08/06 00:01:18	10007	29.24	72.3,85,3,1

Figure 4.4: temperature Humidity log file

Time	Speed
2012/08/07 00:00:03	1.58,183.2,4.2
2012/08/07 00:00:08	1.78,200.0,1.4
2012/08/07 00:00:13	1.50,203.3,0.5
2012/08/07 00:00:18	1.62,190.6,1.4
2012/08/07 00:00:23	1.66,194.3,-0.5
2012/08/07 00:00:28	1.74,194.2,1.1
2012/08/07 00:00:33	1.68,200.1,-2.8
2012/08/07 00:00:38	1.09,202.7,4.6
2012/08/07 00:00:43	1.83,197.0,2.4
2012/08/07 00:00:48	1.69,186.8,-3.0
2012/08/07 00:00:53	1.72,199.6,-3.0
2012/08/07 00:00:58	1.42,201.4,-5.7
2012/08/07 00:01:03	1.43,184.8,0.7
2012/08/07 00:01:08	1.70,182.7,4.0
2012/08/07 00:01:13	1.39,186.0,-2.5
2012/08/07 00:01:18	1.35,182.5,11.5
2012/08/07 00:01:23	1.30,221.5,-9.6

Figure 4.5: wind log file

Date	RainStatus
2012/08/07	00:00:01,NotFound
2012/08/07	00:00:06,NotFound
2012/08/07	00:00:11,NotFound
2012/08/07	00:00:16,NotFound
2012/08/07	00:00:21,NotFound
2012/08/07	00:00:26,NotFound
2012/08/07	00:00:31,NotFound
2012/08/07	00:00:36,NotFound
2012/08/07	00:00:41,NotFound
2012/08/07	00:00:46,NotFound
2012/08/07	00:00:51,NotFound
2012/08/07	00:00:56,NotFound
2012/08/07	00:01:01,NotFound
2012/08/07	00:01:06,NotFound
2012/08/07	00:01:11,NotFound
2012/08/07	00:01:16,NotFound
2012/08/07	00:01:21,NotFound
2012/08/07	00:01:26,NotFound

Figure 4.6: rain log file

### 4.3 Device client controller

By the device controller, window and curtain can access and operate by the Internet. After receiving the operation command from TCTS, Device client controller will check whether it is a correct request or not; if it is right, it passes it to the message handling server, vice versa sends an error notification to TCTS. The request syntax is :

Window controller command : “window” + ID + “close”/”open”

Curtain controller command : “curtain” + ID + “close”/”open”

#### ❖ Operation description

- Receive the command request from TCSC, check whether it is right or not. Hence all the correct commands are defined in one configuration file (see more in the appendix A), therefore, in the command checking step, the device client controller scans the received command with all defined commands in this file, and understands if that command is correct or not.
- Parse the received command and store the information of the appliance to be operated and the operation manner.  
Example: with the command “curtain1 open”, the parsing result is : appliance is “curtain1” and operation manner is “open”
- Create the socket, connect to the Message handling server socket, send the appliance information and control data to the Message handling server

#### ❖ Hardware structure

Figure 4.7 gives the hardware communication structure of the window and curtain. The completed structure of window controller includes DACS, window controller board and Radio box

- DACS: converter the parallel signal to serial signal
- Window controller board: (micro controller unit) board to handles the request command and controller the board. By 1-bytes (8 bits) command, it can give the status decision to Radio box to give the radio signal to open or close 4 windows. In detail, with two open and close status of each window, we have totally 8 possible status, 8 bits command is used for these 8 status.

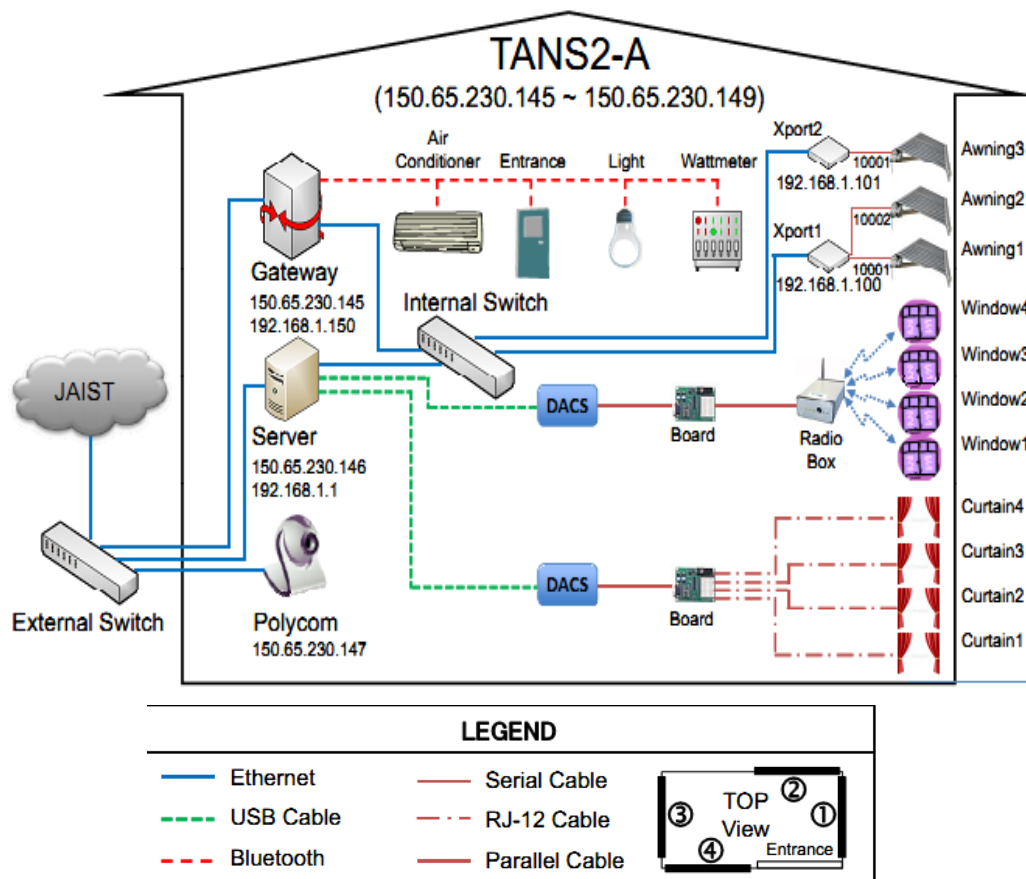

Figure 4.7: the hardware structure of window and curtain controller

The same as the window controller, curtain controller is the combination of DACS, MCU controller board, without the operation of radio box due to the curtains can be operated by the serial communication.

## 4.4 Air conditioner controller

The main handler of air conditioner controller includes socket managing for transmit data with the TCSC module and message handler module. Moreover, the air conditioner controller also provides the air conditioner function library that includes functions to operate the air conditioner. The socket managing module receives request from TCSC, pass it to message

handler module. Then the suitable manner of air conditioner will be active , in some case, the status of air conditioner is sent to TCSC by socket managing module.

The air conditioner function library provides those functions:

- Open/close air conditioner
- Set operation mode: cooling, dehumidifier
- Set temperature
- Get operation mode: cooling, dehumidifier

All of above functions is built base on the foundation of get/set functions of basic ECHONET library. The get/set function of ECHONET library can give the operation for all ECHONET device by the MAC address.

The detail of eoj, epc and edt and the specified value of each ECHONET device class or control data is described detail in [10]. EOJ is the Object type that specify the kind of object such as air conditioner, rain sensor, sound sensor, etc. The information of control target owned by each device is specified as a property, known as edt and the operating method (setting, getting) for this is specified as a service (edt).

ECHONET OBJECT (EOJ)

Here is the get/set functions of a ECHONET device.

- Get : getProperty(bda,eoj,epc)
- Set: setProperty(bda,eoj,epc,edt)

Example: to turn on the air condition ( mac address is 0:03:7a:33:5f:10), the setProperty function is called with the parameter as :

setProperty (00:03:7A:33:5F:10,013001,80,0x30)

#### ❖ Get temperature function

When a request of getting temperature is received from TCSC, the message handler module calls the get temperature function.

#### **Description**

Because the basic getProperty of ECHONET library returns the value of the require command in hex string, so after getting the hex string result data, message handler module convert it to the integer string and send to TCSC by socket transmission. For example : after request to get the current setting temperature to ECHONET air conditioner, message handler module receive the “0x14” hex string result, then it convert to the “20” integer string and flush it to the socket transmission.

#### ❖ Set Temperature function

The message handler module the set temperature request from TCSC in integer string, convert it to hex string and call the ECHONET library set function.

## **4.5 Thermal comfort controller**

Thermal comfort controller (from now called by TCC) is the main controller of TCSC. It manage the environment data by the sensor network, monitor the home device by collaborate with device client controller and air conditioner controller. The effect of the TCSC to the inside air and inside comfort is record to the logger file that includes NCI and NET indexes for evaluating and monitor the operation result.

### 4.5.1 Controller algorithm

In circularly, our system checks whether the indoor comfort is achieved or not. Then check out the home device status and outdoor air, give the control requests to the suitable devices.

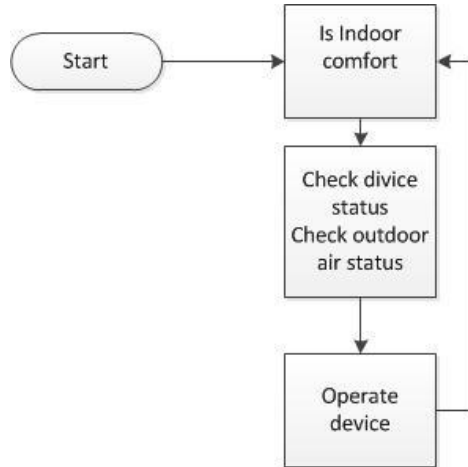

Figure 4.8: basic algorithm

Our system base on the environment formation to give the decision to home device : curtain, window and air conditioner. Under the active operation of these device, the inside thermal factor will be changed. Table 4.1 give the relationship of home device and thermal comfort factor. The operation of air conditioner affects to inside temperature and humidity, fan give the air flow and change the inside wind speed, while the open or close action of window and curtain get the outside climate factor into inside and give impact to inside temperature, humidity and wind.

Home devices	Thermal comfort factor
Air conditioner	Inside temperature/humidity
Fan	Wind
Window, curtain	Inside temperature/humidity/wind

Table 4.1 : the relationship between home devices and thermal comfort factors

The operation of main algorithm is aim to get the inside home thermal comfort. Periodically, TCC get the environment information: temperature, humidity, wind and rain of inside and outside home. Base on these data, TCC evaluate whether the inside home is already achieved or not. In the case that the inside environment has the comfort status, TCC will keep this status. Otherwise, if the indoor is not comfort, TCC will try to control the window and air conditioner to get the home comfort. The window will be opened if the outdoor air is acceptable, the outside air is get into the inside home make positive effect to the inside temperature,

humidity, wind with the purpose to create a comfort space to the inside home. If the outdoor air is not good as expected, window will be closed and the home thermal comfort is decided by the air conditioner operation. TCC controls the air conditioner in the suitable manner, try to reduce the high humidity and set the appropriate temperature to get the home comfort.

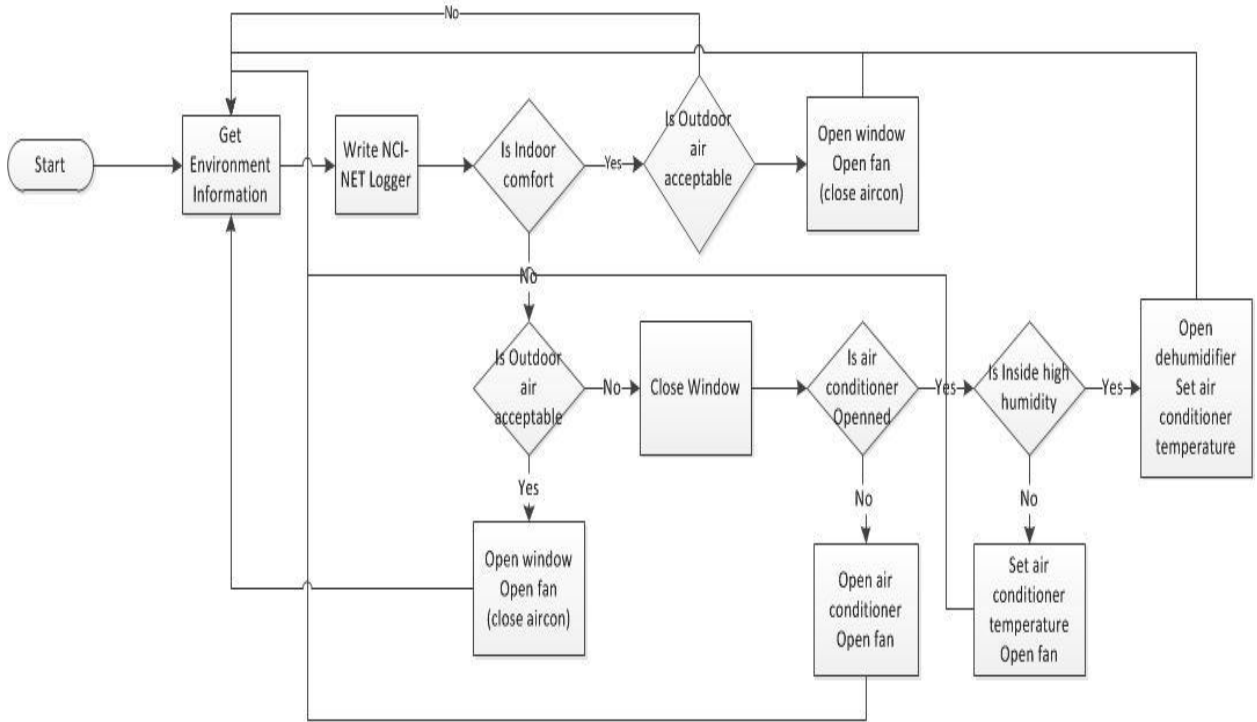

Figure 4.9: TCC manner algorithm

By the research of Tokyo Environmental agency in [11], if air conditioner ups 1°C, the system can save 10% consumption energy. Therefore, the use of electric fan to create the air flow circulation, set air temperature higher can bring the better electric efficiency. This is the reason in our algorithm fan is used almost of the time whenever the outdoor air is acceptable or not acceptable, air conditioner is on or off.

As mentioned in section 3.2, the Indoor thermal comfort is evaluated by two indexes : Not Comfort Index (NCI) and net effective temperature (NET) that expressed the human sensible temperature. The indoor thermal comfort is achieved in the case the NCI in the range of 60-70 and NET is in 19-25. The outdoor is acceptable in case: NCI is in 60-70, relative humidity is not high: lower than 90%, wind speed lower than 9 m/s and no rain. If these norm is all acceptable, the outdoor air is acceptable that means human feel comfort with the outside air. In detail, if the outdoor air acceptable, the window opens for take the outdoor air to inside. While the use of fan makes the inside air flow and reduce the energy consumption from the air conditioner by setting higher temperature.

TCC is structured with those main modules: Client socket module, Device manager module, Environment manager, NCI NET Logger.



## 4.5.2 Client socket module

In our implementation, there are many different servers for serving requesting of sensor data, control device (window, curtain) and air conditioner operation. Totally , there are 4 servers:

- Temperature humidity data server
- Wind rain server data
- Device client server
- Air conditioner controller

And client socket module of TCSC manages the socket of client that connects to those servers for requesting data, and receiving data. Client socket modules is implemented with some basic functions for socket communication such as:

- Create and connect to server socket
- Send inquiry to server
- Receive data from server
- Close the socket

Moreover, each client socket has a separated in/out buffer for receiving/sending data.

## 4.5.3 Device manager module

Device manager module monitors the status and gives the operation decision to window, curtain and air conditioner.

### ❖ Window/curtain manager

By the client socket that connecting to the device client module, the device manager modules can control window and curtain. This includes these functions :

- Open window/curtain
- Close window/curtain

Moreover, the status of window (open/close) also be monitored by the device manager module

### ❖ Air conditioner manager

Air conditioner manager understand the status manner of air conditioner and operates the air conditioner by set and get operation through the client socket connects to air conditioner cotroller. It provides following operation to air conditioner:

- Open/close air conditioner
- Set operation mode: cooing, dehumidifier
- Set temperature
- Get on/off status: for understanding the air conditioner is on or off at that time
- Get temperature

If the air conditioner manager wants to set the manner to air conditioner, it sends a string message to air conditioner controller. The syntax of string requesting message to air conditioner is defined as below.

- Open air conditioner: “openAircon”
- close air conditioner: “closeAircon”
- Set cooling operation mode: “openCooling”
- Set dehumidifier operation mode : “openHumid”
- Set temperature “setTemp “ temperature value. Example: “setTemp 25” for setting room temperature at 25<sup>0</sup>C

- Get on/off status: “getOnOffStatus”
- Get temperature : “getTemp”

The result of the inquiry from the get temperature function is an integer string that sent from the air conditioner controller. This integer string is converted and stored to integer data for latter operation of TCSC.

The class diagram of air conditioner is shown below.

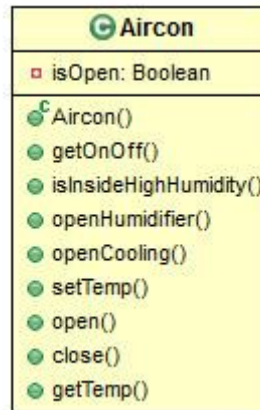

Figure 4.10: class diagram of aircon class

#### 4.5.4 Environment manager

Our system, periodically, gets the environment information (temperature, humidity, wind, rain) of inside and outside. Therefore for managing easily the current environment status, Environment manager divides to two main separated components : indoor and outdoor components. The indoor component manages the indoor status of temperature, humidity and wind, while the outdoor component handles the outdoor temperature, humidity, wind and rain.

In section 3.2, two indexes NCI and NET is introduced as the indexes for evaluating the indoor comfort. Therefore, besides monitors the information of thermal comfort factors (temperature, humidity, wind), the indoor component also store the NCI and NET indexes. NCI and NET indexes is calculated from the data of inside temperature, humidity, wind. Outdoor component includes the outdoor NCI indexes by storing the information of outdoor temperature, humidity, wind.

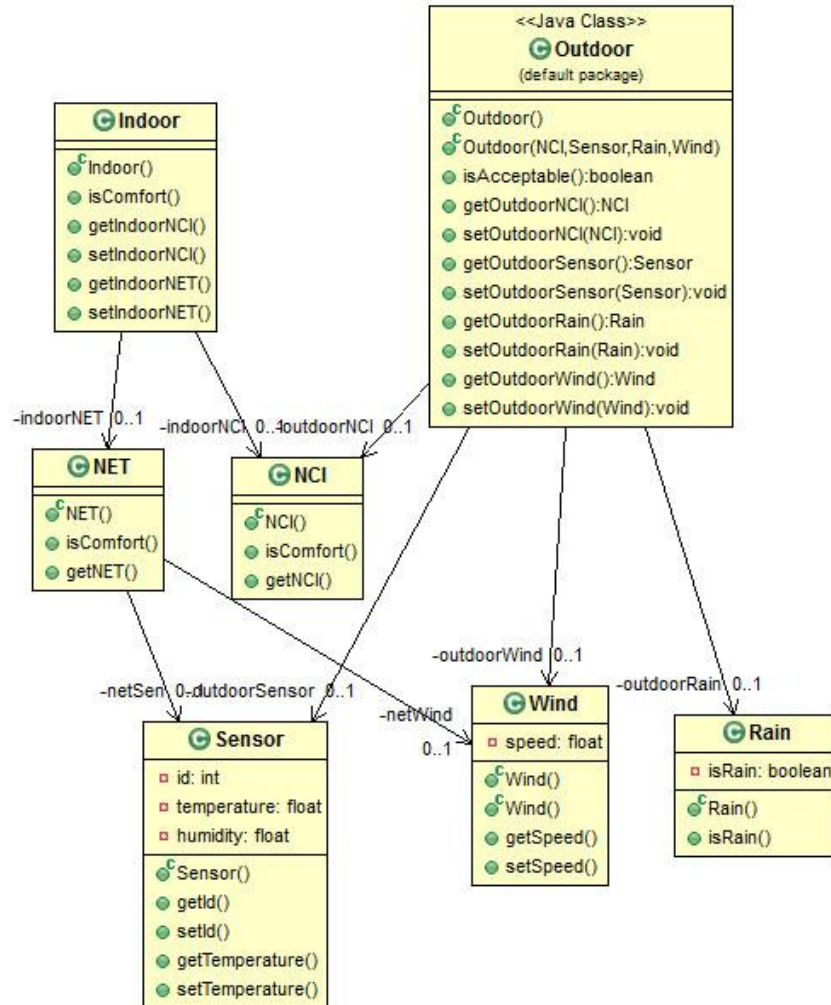

Figure 4.11: class diagram of Indoor and Outdoor class

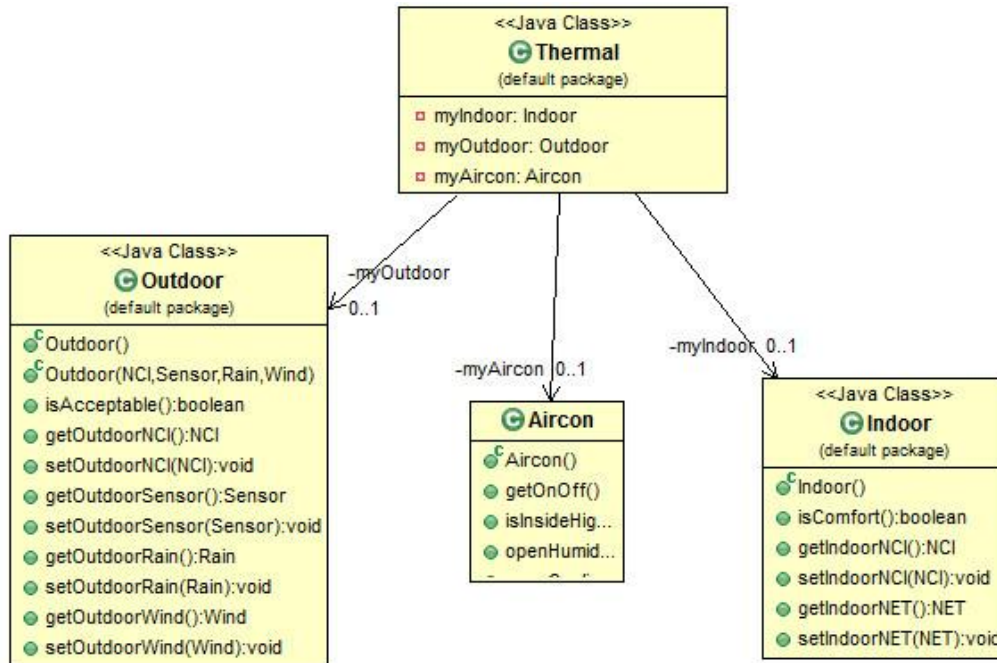

Figure 4.12: class diagram of Thermal class

As the figure 4.12, the NCI and NET class consists the functions to check whether current NCI and NET is comfort or not. The detail of thermal comfort evaluation methodology can found in section 4.6.1. Due to the fact that the temperature and humidity sensor is embedded in one sensor, class Sensor is implemented for storing the information of temperature and humidity sensor. Class Wind and Rain are represented for implementation of wind and rain sensor.

Environment manager provides function for getting the current information of surrounding environment by sensor network. The function library of environment manager is explained below

- ❖ **getInsideTempHumidity** : get the current inside temperature and humidity
  - Input: The logger file from the temperature/humidity server
  - Output: the sensor object that includes of current inside temperature and humidity
  - Description : Environment manager send inquiry to TempHumidity server module to requesting the temperature and humidity information. Then the TempHumidity server read the TempHumidity log file, send back current inside and outside temperature and humidity to the environment manager. The average inside temperature and humidity is restored to the one sensor object.
- ❖ **getOutsideTempHumidity**:
  - Input: The sensor log file from the temperature/humidity server
  - Output: the sensor object that store current outside temperature and humidity
  - Description: from the received of requesting data from TempHumidity server, the average temperature and humidity of inside and outside are restored to the separated sensor object. The average outside temperature and humidity is restored to the one sensor object.

- ❖ `getRainWindData`:
  - Input: wind and rain logger file from the wind/rain server
  - Output: wind object and rain object store the current average wind speed and rain status
  - Description: Environment manager sends inquiry to wind rain server module to requesting the wind and rain information. Then the wind/rain server read the wind log file and rain log file, send back current wind and rain information to the environment manager. The average current average wind speed and rain status are restored to separated wind object and rain object.

#### 4.5.5 NCI NET Logger

- Input: the inside NCI, NET and outside NCI
- Output: the inside NCI/NET log file and outside NCI log file as in below figures. The NCI/NET log file stores the information of time and NCI, NET indexes.
- Description: after getting the environment information, the inside NCI, NET and outside NET is calculated. Then the NCI NET logger saves these information to inside NCI NET log file and outside NET log file.

```
Time NCI
00:17 76.46418
00:17 76.46418
00:17 76.46418
00:17 76.46418
00:17 76.46418
00:17 76.46418
00:18 76.46418
00:18 76.46418
00:18 76.46418
00:18 76.46418
00:18 76.46418
00:18 76.46418
00:18 76.46418
00:18 76.46418
00:18 76.46418
00:20 76.48407
00:20 76.48407
00:20 76.46951
00:20 76.46951
```

Figure 4.13: NCI file

```
Time NET
00:17 21.341671
00:17 21.341671
00:17 21.341671
00:17 21.341671
00:17 21.341671
00:17 21.341671
00:18 21.341671
00:18 21.341671
00:18 21.341671
00:18 21.341671
00:18 21.341671
00:18 21.341671
00:18 21.341671
00:18 21.341671
00:18 21.341671
00:18 21.341671
00:20 25.745804
00:20 25.745804
00:20 25.737862
00:20 25.737862
00:25 25.725431
```

Figure 4.14: NET file

# Chapter 5

## Experiment and evaluation

### 5.1 Experiment method

#### 5.1.1 Experiment environment

The thermal comfort controller is installed and done experiment in the TANS2A home. TANS2A home has about 12 square metres, and is equipped with some home device can be remote controlled by the user through the internet. Figure 5.1 is the overview from the outside of TANS2A home. Figure 5.2 shows the equipped home device of TANS2A and the detail hardware structure of all devices.



Figure 5.1 : outside view of TANS2A

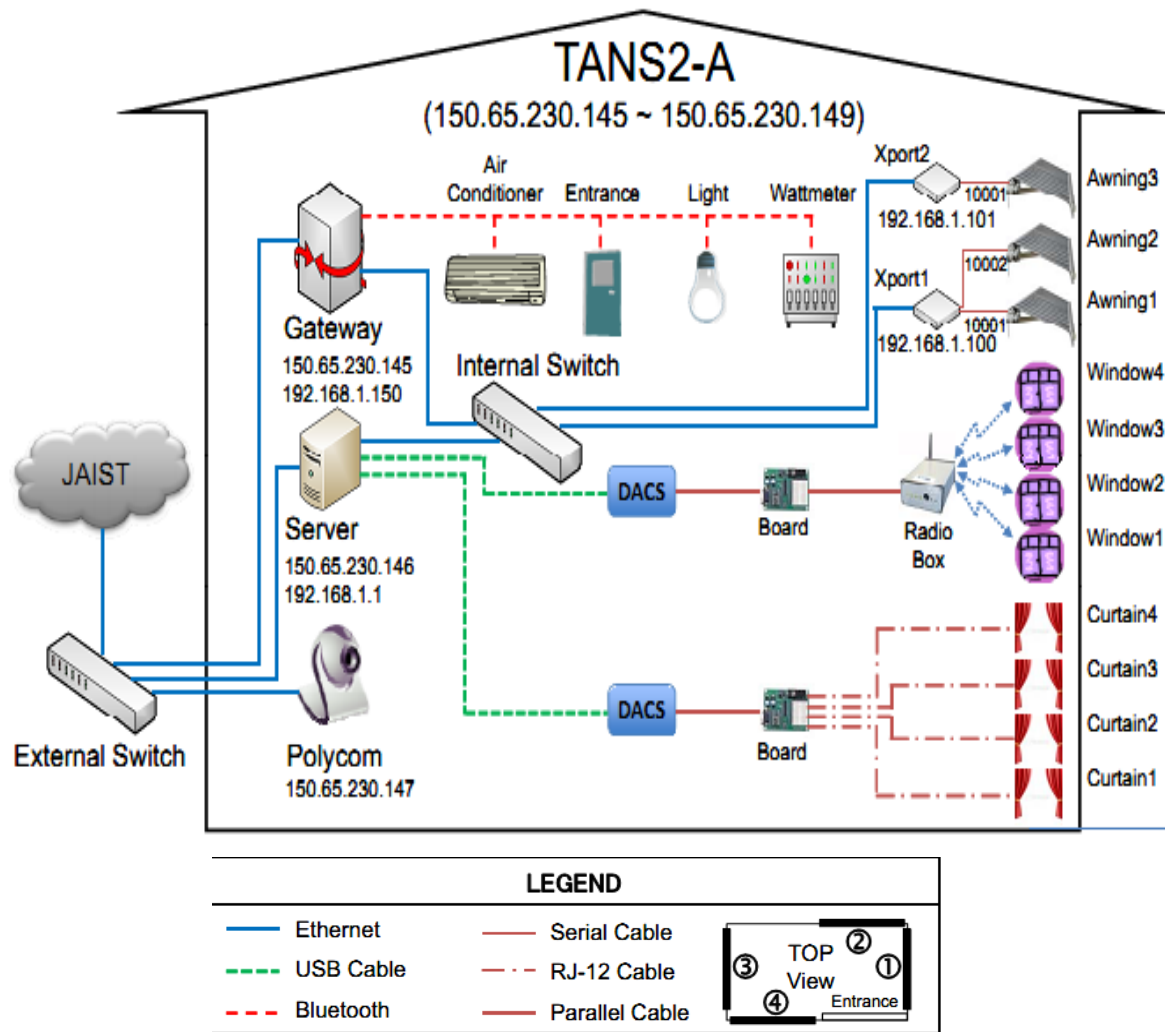

Figure 5.2: TANS2A hardware device structure

There are four windows, four curtains and one air conditioner in TANS2A.

### 5.1.2 Sensor and device

#### ❖ Temperature humidity sensor

Senshirion SHT-11 Temperature humidity sensor is used in TANS2A. Senshirion SHT-11 sensor is the integrate sensor of relative humidity and temperature sensors[12] and can transmit data with PC by the USB protocol. Three child nodes of sensors and one coordinator node are set the same PAN ID and channel to create one sensor network, and the coordinator code is connected to the server by USB cable. Periodically, 4 child nodes send its sensor ID, temperature, humidity to coordinator node. By the USB protocol, coordinator send data to server and these information then are recorded to the temperature humidity log file as decribed in section 4.2. Three child sensor nodes is distributed with the equal distance in the center of TANS2A to get the inside information (as Figure 5.3), and one child sensor node in outside TANS2A. Therefore, the inside temperature humidity that Environment manager of TCSC is the everage value of the data of 3 inside child nodes, and the outside temperature humidity is the data receives from outside node.





Figure 5.3: three temperature Humidity server in TANS2A

❖ Wind sensor and Rain sensor

Both wind sensor and rain sensor are the ECHONET sensor. The used wind sensor is a 3D-wind-sensor, that means it can detect the direction of wind but this function is not necessary in this research while we just care about the wind speed.

Fan: two kinds of fans are used in the experiment

- Green Fan 2: give wind directly to human. Green Fan 2 has 4 levels for setting the wind speed. Due to Green Fan 2 can not be remote controlled by internet, so in the experiment scenarios, base on the weather condition, it will be set by a fixed value during the experiment time.

Level	Wind speed (m/s)
1	0.1
2	0.2
3	0.8
4	2.2

Wind speed of each level of Green Fan 2

- Green Fan: make the air flow circulation in the room

Experiment installation:

Components of our system are distributed in different server as summarized in the figure 5.4

- TCSC, device client controller, air conditioner controller all the needed components for controlling windows and curtains are installed all the sever of TANS2A.
- Temperature humidity sensor sever is installed in a indepedent server called tempHumidSensor sever
- Wind rain sensor sever is installed in the IHouse server, wind sensor and rain sensor are connect to the UPNP of IHouse. IHouse is also a experiment smart home with the bigger scale than TANS2A (see in figure xxx)

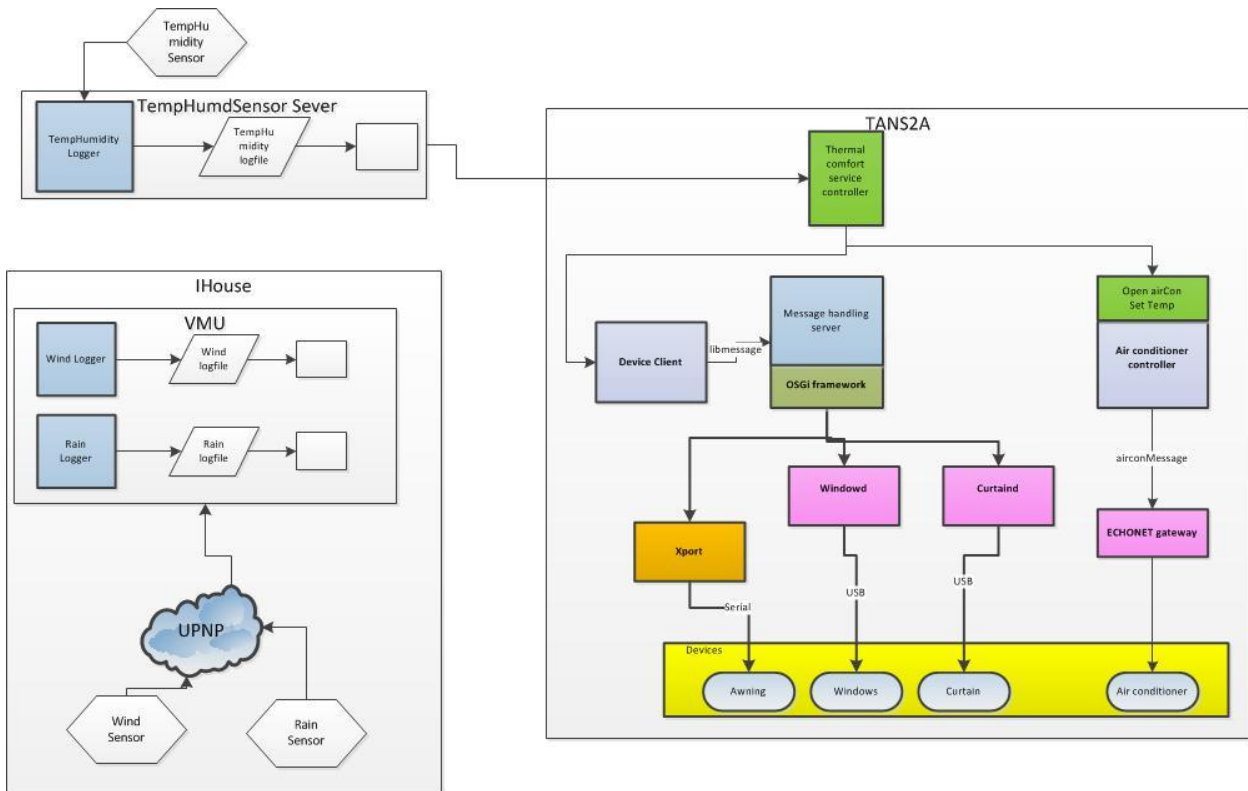

Figure 5.4: system installation figure



Figure 5.5: the outside view of IHouse

## 5.2 Evaluation method

TCSC is installed to the TANS2A experiment home, how this system make inside human thermal comfort is evaluated by two thermal comfort indexes : NCI and NET, while the energy consumption is also measured. Under the operation of TCSC, NCI and NET will be recorded continuously for statistic, at the same time the energy consumption is also be observed. In sum, the performance of TCSC is considered by evaluates the inside NCI, NET, and the energy consumption.

For evaluating the performance of TCSC compared with other systems, another system just used air conditioner with the same purpose is to achieve the inside thermal comfort is implemented and installed in TANS2B. TANS2A and TANS2B have the same square area, and inside structure and constructed by the same material. After that, the performance of two different system in TANS2A and TANS2B are evaluated base on how thermal comfort it makes and the efficiency in energy consumption, three evaluate indexes are NCI, NET and power consumption are observed and compared between two systems.



Figure 5.6: outside of TANS2A and TANS2B

❖ Test case

- In TANS2A: when air conditioner is on, TCSC will control NET about 25<sup>0</sup>C
- In TANS2B: the inside NET is also controlled in 25<sup>0</sup>C, the same with TANS2A

Figure 5.7 express the control algorithm in TANS2B to achieve desire inside NET. Base on the current inside temperature and humidity (wind speed is 0, because not use fan), air conditioner set the suitable temperature. Furthermore, the inside NCI and NET is also recorded to the log file (as in TCSC system described in section 4.6) for monitoring the performance of system operation in TANS2B. The experiment diagram in TANS2B is shown in Figure 5.8.

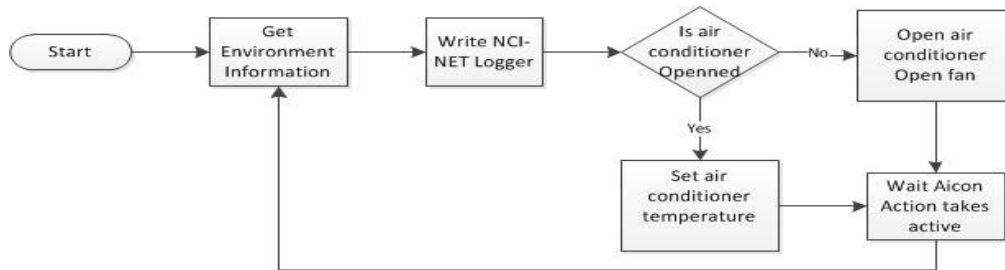

Figure 5.7:TANS2B system control algorithm

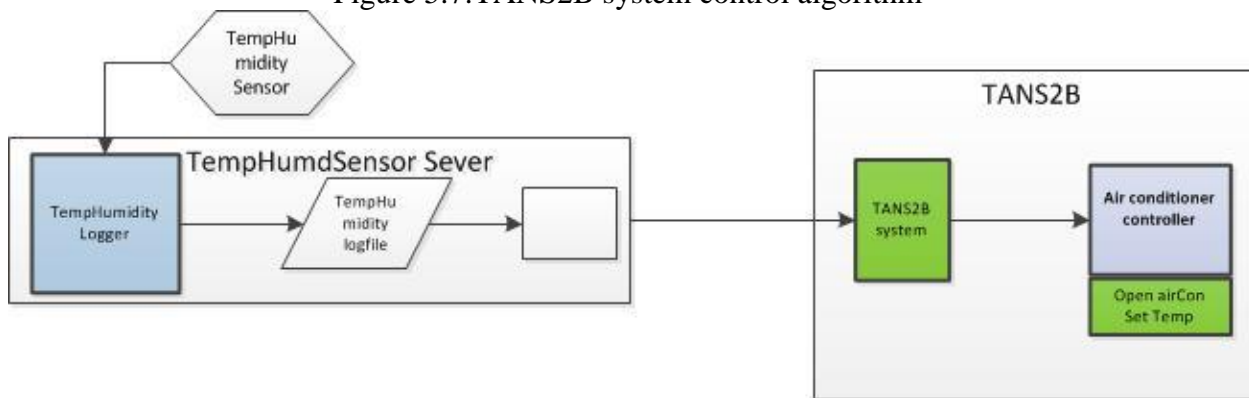

Figure 5.8: TANS2B experiment diagram

❖ TANS2B experiment system

**Temperature Humidity sensor :** Use the same method in the server that implemented in TANS2A (see section 5.1) for collecting the temperature humidity data, 3 sensor nodes are distributed with the equal distance in the center of TANS2B to get the inside information. Moreover, these 3 sensor nodes of TANS2B and 3 inside sensor nodes, 1 outside sensor nodes of TANS2A, is set up in the same sensor network. Figure 5.9 is the entire temperature and humidity logger file that storing the sensor data of both TANS2A and TANS2B. The detail sensor ID of sensors that used in TANS2A and TANS2B is summarized in table 5.1.

Location	Sensor ID
Inside TANS2A	8001, 8003, 8005
Outside TANS2A	10003
Inside TANS2B	9001, 9003, 9005

Table 5.1: the temperature humidity sensor in TANS2A and TANS2B

```

Time, Sensor ID, Temperature, Humidity
2012/08/06 00:00:00,8005,29.32,75.2,22,3,3
2012/08/06 00:00:03,8001,28.56,77.7,22,3,3
2012/08/06 00:00:05,9003,28.88,68.93,22,3,1
2012/08/06 00:00:16,10004,28.8,80.13,98,3,3
2012/08/06 00:00:16,9005,29.2,67.59,20,3,1
2012/08/06 00:00:18,10007,29.2,72.3,78,3,1
2012/08/06 00:00:18,8003,28.8,76.46,17,2,3
2012/08/06 00:00:20,10003,26.36,87.0,20,3,2
2012/08/06 00:00:30,8005,29.28,74.66,24,3,3
2012/08/06 00:00:33,8001,28.56,77.7,20,3,3
2012/08/06 00:00:35,9003,28.88,68.93,22,3,1
2012/08/06 00:00:46,9005,29.2,67.59,20,3,1
2012/08/06 00:00:46,10004,28.76,80.13,98,3,3
2012/08/06 00:00:48,10007,29.24,72.3,78,3,1
2012/08/06 00:00:49,8003,28.84,76.46,17,2,3
2012/08/06 00:00:50,10003,26.36,86.91,20,3,2
2012/08/06 00:01:01,8005,29.32,75.2,22,3,3
2012/08/06 00:01:03,8001,28.56,77.7,24,3,3
2012/08/06 00:01:05,9003,28.88,68.93,22,3,1
2012/08/06 00:01:16,9005,29.16,67.59,20,3,1
2012/08/06 00:01:16,10004,28.72,80.13,92,3,3
2012/08/06 00:01:18,10007,29.24,72.3,85,3,1

```

Figure 5.9: the temperature humidity log file of both TANS2A and TANS2B

### 5.3 Result

The experiment is conducted in both TANS2A and TANS2B in the same time, collect the NCI and NET indexes during experiment time and measure energy consumption. Some test cases in given, they have different condition of outdoor air to compare the performance between two system in TANS2A and TANS2B in variety situations.

- ❖ Test case 1:
  - Scenarios:
    - Experiment time: from 12:40 to 15:20 am, summer
    - Outdoor condition: extremely hot
      - Average temperature: 39.07
      - Average Humidity: 43.14
      - Average NCI : 87.7

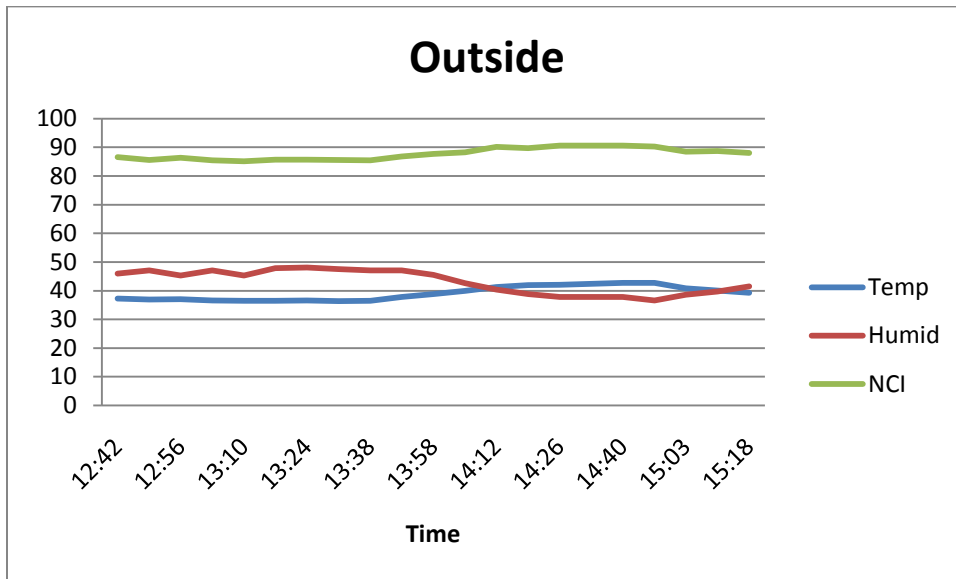

Outside weather condition of testcase 1

- System operation: Due to high temperature, the outdoor air is not acceptable, so the window in TANS2A is closed all time and just air conditioner and fan is used. The Green fan 2 wind speed is set in 2.2 m/s
- Result

The result of two thermal comfort evaluation NCI and NET of them is shown in Figure 5.19. Table 5.2 show the summary evaluation of 3 indexes: NCI, NET, energy consumption.

- NCI: the average NCI during the experiment time in TANS2A and TANS2B almost equally
- NET: the TCSC system in TANS2B give the comfortable sensible temperature with lower NET in about 24<sup>0</sup>C and 25<sup>0</sup>C.
- Energy consumption: TANS2A has better energy efficiency when consumes less energy than TANS2B.

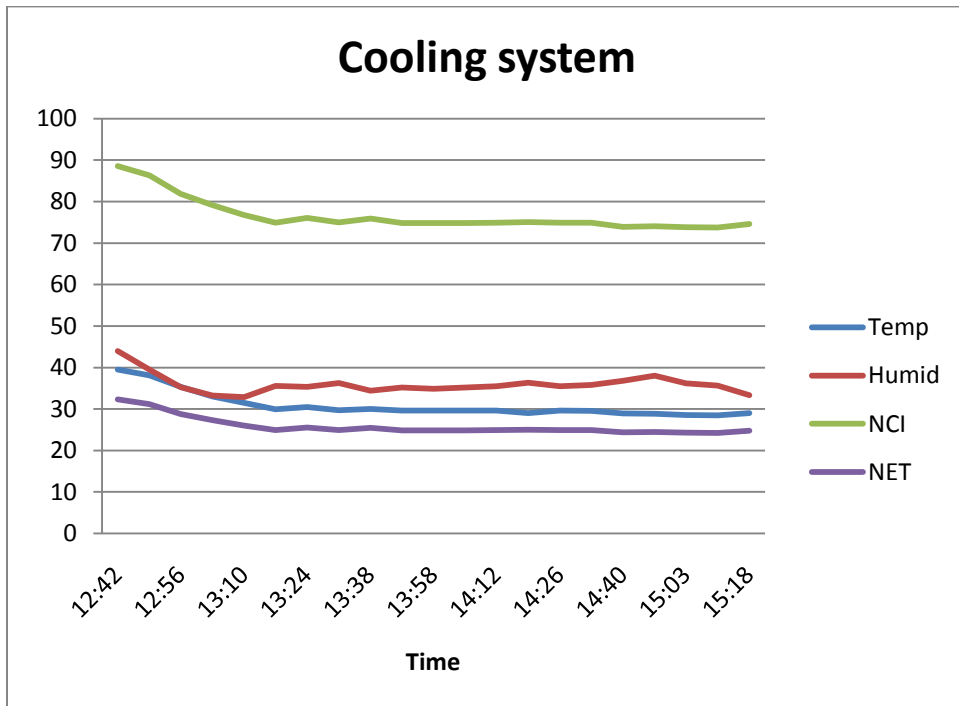
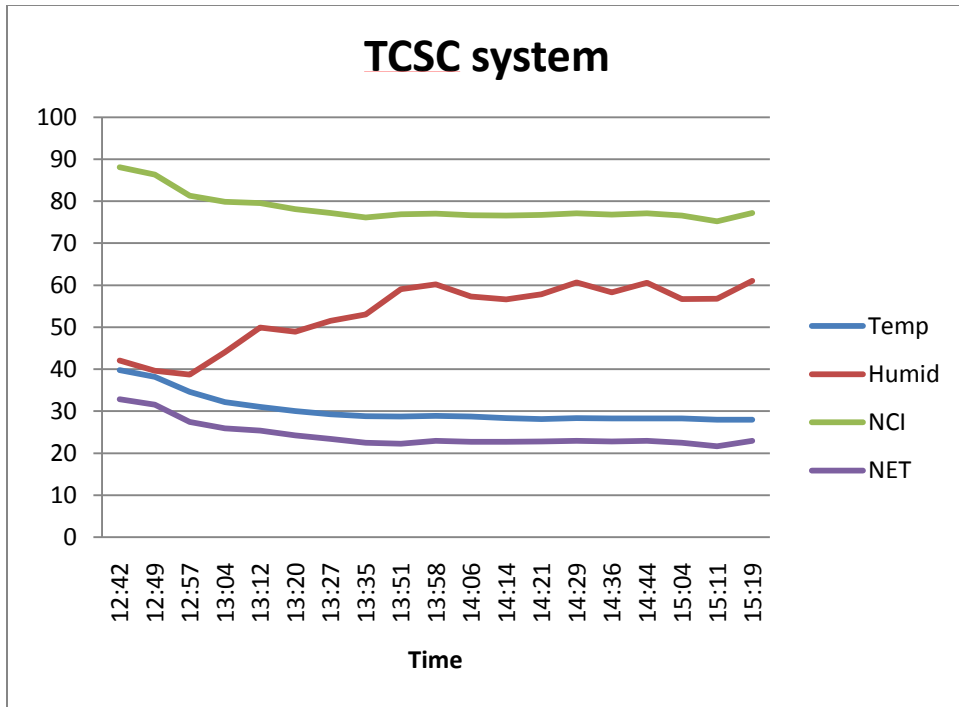

Figure 5.19: the experiment result of test case 1

	TCSC system	cooling system
--	-------------	----------------

NCI	78.45	76.61
NET	24.33	25.85
Energy consumption (Wh)	582	648

Table 5.2: the average NCI NET and energy consumption of test case 1

❖ Test case 2

▪ Scenarios:

- Experiment time: from 5:40 am to 11:40 am, summer
- Outdoor condition: **Hot**
  - Average temperature: 30.08
  - Average Humidity: 62.63
  - Average NCI : 79.2

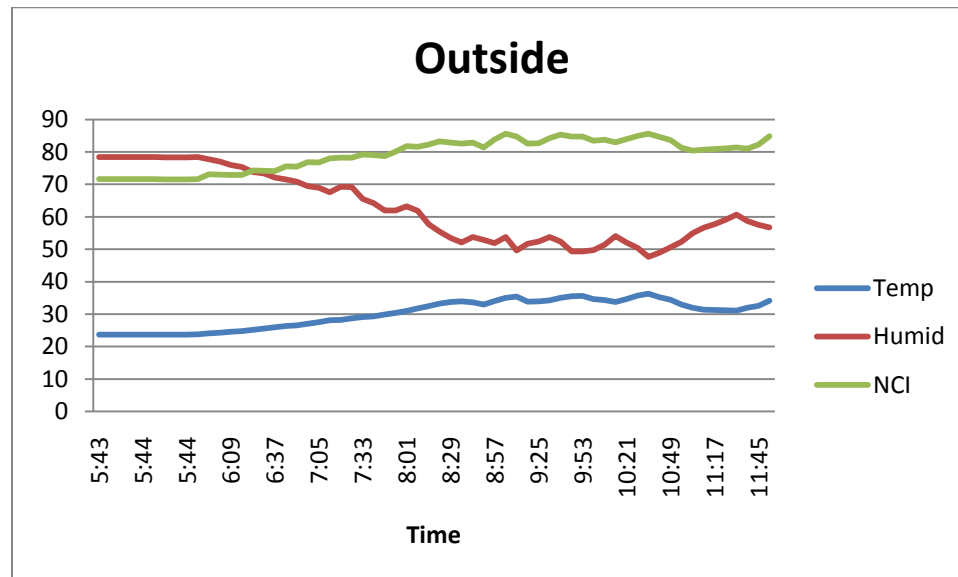

Figure 5.20: outside condition during the experiment time of test case 2

- System operation: Due to high temperature, the outdoor air is not acceptable, so the window in TANS2A is closed all time and just air conditioner and fan is used. The Green fan 2 wind speed is set in 2.2 m/s

▪ Result

The result of two thermal comfort evaluation NCI and NET of them is shown in Figure 5.21. Table 5.3 shows the summary evaluation of 3 indexes: NCI, NET, energy consumption.

- NCI: not big different in two system



- NET: the TCSC system in TANS2A give the more comfortable sensible temperature lower NET in about 22.01.
- Energy consumption: TANS2A has better energy efficiency.

	TCSC system	cooling system
NCI	76.15	73.67
NET	22.01	24.24
Energy consumption (Wh)	1212	1267

Table 5.3: the average NCI NET and energy consumption of test case 2

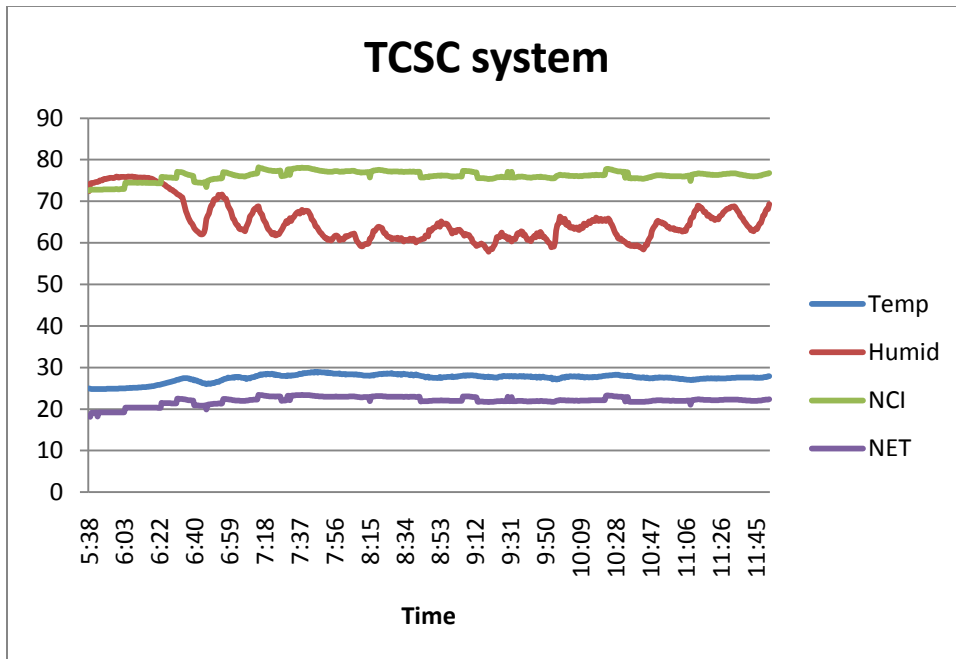

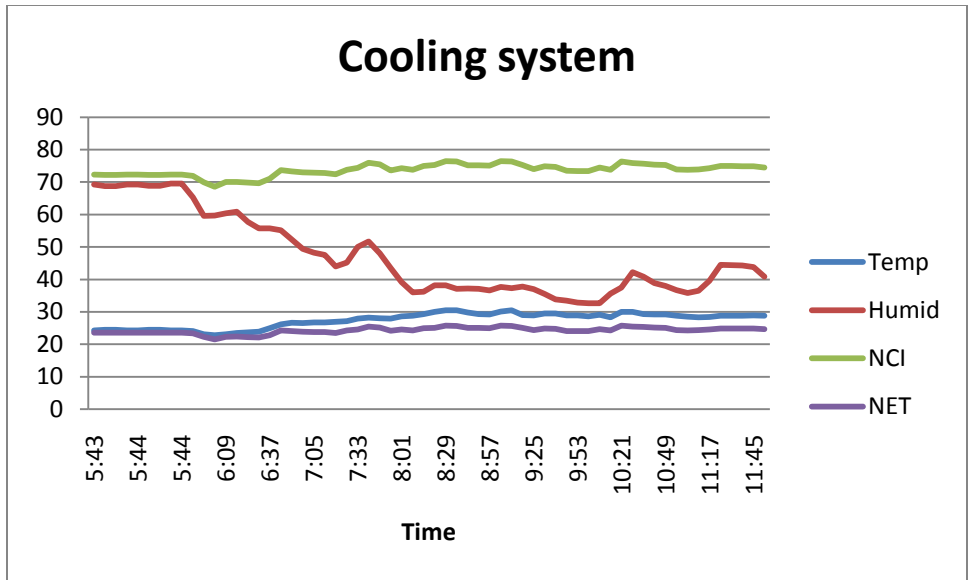

Figure 5.21: the experiment result of Test case 2

❖ Test case 3

▪ Scenarios:

- Experiment time: from 0:30 am to 3:10 am, summer
- Outdoor condition: **Cool**
  - Average temperature: 21.28
  - Average Humidity: 79.4
  - Average NCI : 67.85

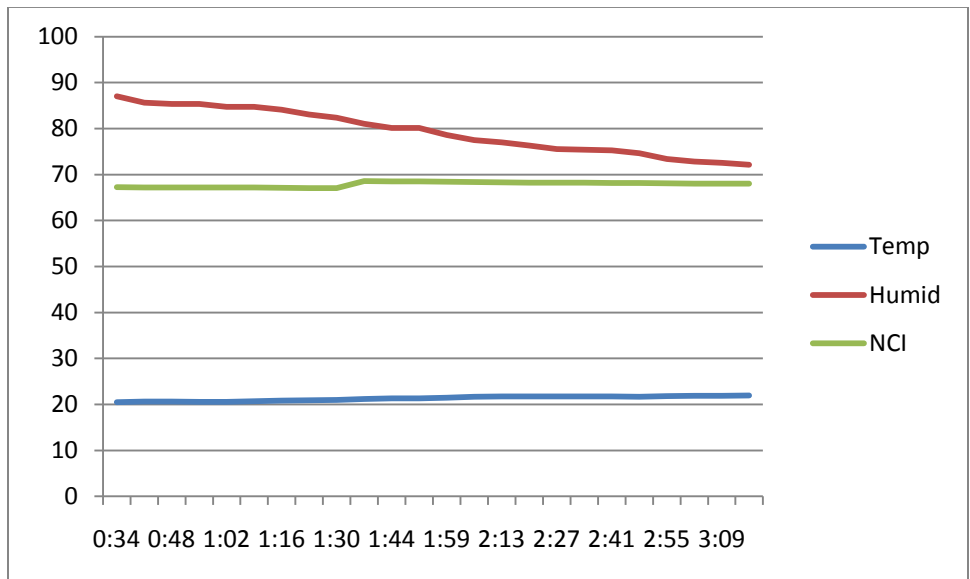

Figure 5.22: outside condition during the experiment time of test case 3

- System operation: Due to the outdoor air acceptable, the window and curtain is opened to get the outside air into inside and air conditioner is not used, fan is set at speed of 0.2 m/s, when TANS2B just use the air conditioner.

▪ Result

The result of two thermal comfort evaluation NCI and NET of them is shown in Figure 5.213. Table 5.4 shows the summary evaluation of 3 indexes: NCI, NET, energy consumption.

- NCI: not big different in two system
- NET: NET of both systems is almost equal with the outside air temperature
- Energy consumption: TANS2A has better energy efficiency due to the not use of air conditioner

	TCSC system	cooling system
NCI	67.88	65.97
NET	21.05	23.29
Energy consumption (Wh)	35.43	214.88

Table 5.4: the average NCI NET and energy consumption of test case 3

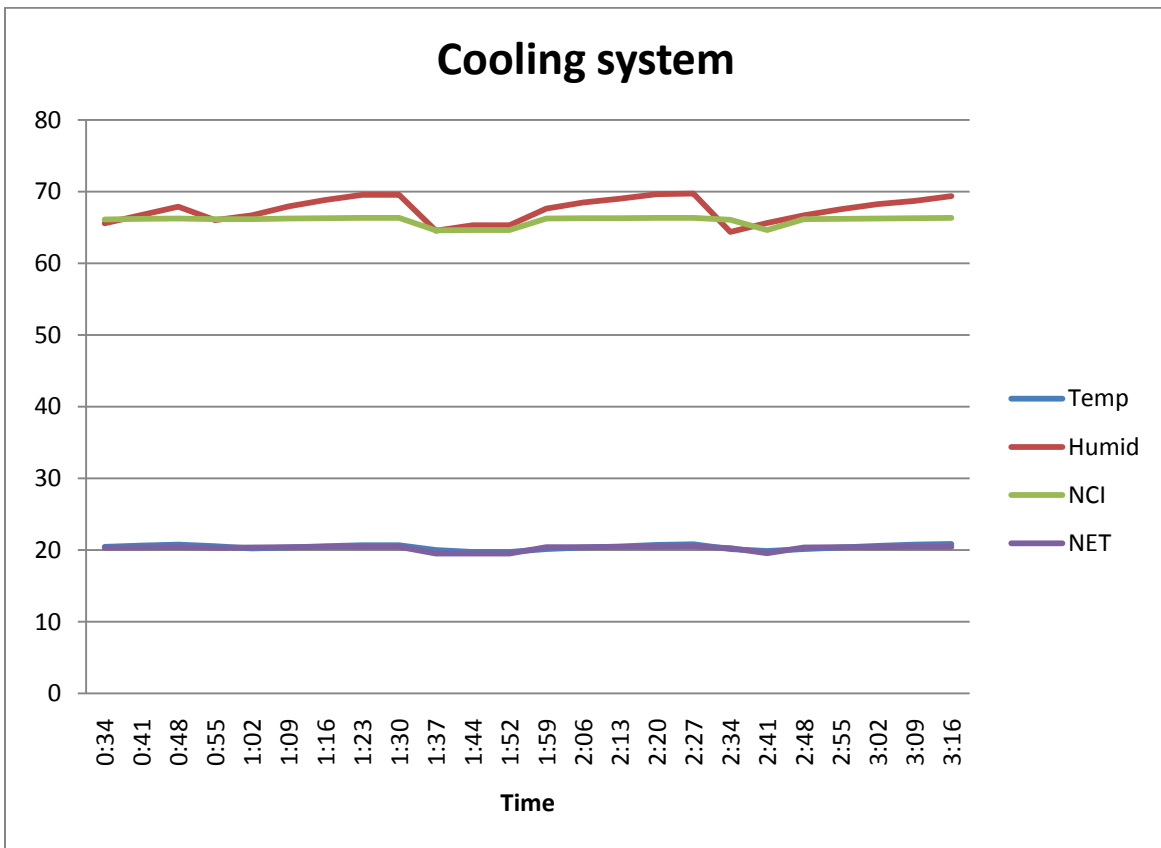
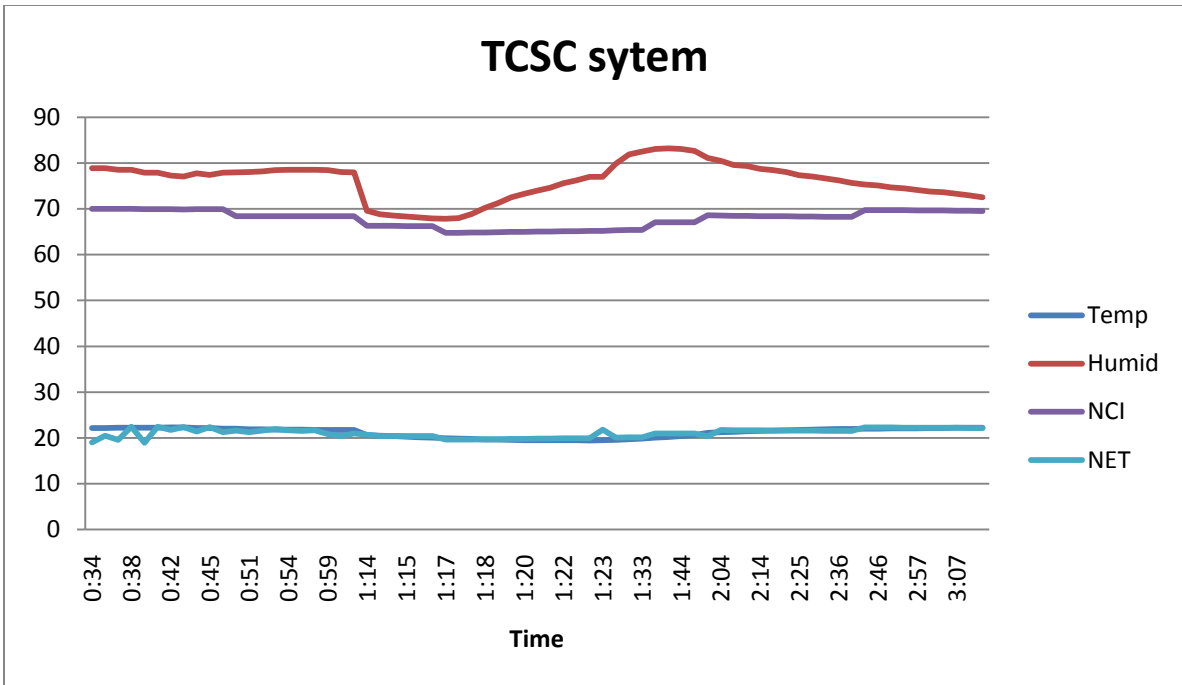

Figure 5.23: the experiment result of Test case 2

## 5.4 Conclusion – Future work

### 5.4.1 Conclusion

The implemented TCSC system is structured with variety modules of getting-information-modules, device-control-module, and controller module, etc but runs smoothly and has no error in device control during a long time about 10 hours. TCSC system achieves to the proposed purpose : inside thermal comfort and energy efficiency. Base on the information received from sensor network, it understands the surrounding environment condition of air temperature, humidity, wind and rain. It is also an important point is our experiment is the using temperature and humidity sensor gives the correct measurement data, almost has no errors. In the cool weather when the outside condition is acceptable, by the combination of use outside air and fan, air conditioner is turned off and give good performance in energy consumption. However, when in the hot or extreme hot condition, the TCSC just save 8% energy consumption than the cooling system.

Moreover, fan can not be controlled automatically also one point that decrease the dynamic feature of this system. By making decision, control automatically the fan can bring the better system performance. Because the dependence on the climate condition, the experiment test case is limited in some weather scenarios, there is just one test case for the cooling weather when the outside air is acceptable.

Current experiment environment is just a simple structure of building, it not familiar to a human living house, the achievement of this document can be applied for expanding to bigger house with many division spaces when the different effect of air conditioner and outside air to the separated space and common space should be consider carefully.

### 5.4.2 Future work

❖ Expand the system with meant radiant temperature factor

Meant radiant temperature is also an important for of thermal comfort, it is a concept arising from the fact that the net exchange of radiant energy between two objects is approximately proportional to their temperature difference multiplied by their ability to emit and absorb heat (emissivity). As the quality of wall increases, the wall is also warmer and therefore higher the mean radiant temperature. The higher the mean radiant temperature the less discomfort in the space. Maintaining a balance between the operative temperature and the mean radiant temperature can create a more comfortable space.

The future work is to improve this system by taking the main radiant temperature into this model, such as measure the radiant temperature of wall and roof and improve the thermal comfort algorithm which is base on the information of air temperature, relative humidity wind, rain and meant radiant temperature

❖ Fault tolerant

The system is combined with a lot of component that distributes in different server, therefore the risk of making the system fault is fairly high. For example, when the sensor out of battery or get some problem that does not give the incorrect measurement data or give the humidity in minus value, TCSC must be found these errors after getting the environment data.

Another risk scenarios is under the control of TCSC, window is opened, if it rains, the current TCSC system can not know this situation immediately for deciding to close the window. A proposed solution is to create a rain detection system that can discover immediately if it rains and give the notification to TCSC.

## Bibliography

- [1] John S. Whinery, “Space conditioning system with outdoor air Space conditioning system with outdoor air and refrigerant heat control of dehumidification of an enclosed space”, US Patent US006427461B1, 2002
- [2] P.W. Li & S.T. Chan, “Application of a Weather Stress Index for Alerting the Public to Stressful Weather in Hong Kong”, pp. 369-371, 2000
- [3] Tzu-Ming Wang, Po-Chun Lin , “Energy Saving of Air Condition using Fuzzy Control System over Zigbee Temperature Sensor”
- [4] ホームネットワークサービスおよびそのシステムの実証、岡田 崇(September, 2011)
- [5] Wireless sensor networks: a survey I.F. Akyildiz, W. Su\*, Y. Sankarasubramaniam, E. Cayirci, pp. 397
- [6] Byoung-Kug Kim, Sung-Hwa Hong, Young-Sik Jeong, Doo-Seop Eom, “The Study of Applying Sensor Networks to a Smart Home” , pp. 677
- [7] Yong Yang, Junmei Guo, “A Study on Home Information Network”, 2011 International Conference on Uncertainty Reasoning and Knowledge Engineering
- [8] Ken PARSONS , “Heat Stress Standard ISO 7243 and its Global Application”, pp. 368-370
- [9] Steadman, R. G.: 1994, “Norms of Apparent Temperature in Australia”
- [10] Appendix Detailed Stipulations for Echonet Device Objects
- [11] 東京環境局、「遊技施設の省エネルギー対」、pp.18
- [12] Sensirion company, “Datasheet SHT1x (SHT10, SHT11, SHT15)”

# Appendix A : Home device command configuration file

```
# 2010.04.20 tans2.conf
# APPLIANCE_NAME EOJ0 EOJ1 EOJ2 PROPERTY_NAME EDT EPC
```

```
# awning1: east, awning2: west, awning3: north, awning4: south
awning1 02 40 01 open 41 e0
awning1 02 40 01 close 42 e0
awning2 02 40 02 open 41 e0
awning2 02 40 02 close 42 e0
awning3 02 40 03 open 41 e0
awning3 02 40 03 close 42 e0
```

```
# window1: east, window2: west, window3: north, window4: south
window1 02 41 01 open 41 e0
window1 02 41 01 close 42 e0
window2 02 41 02 open 41 e0
window2 02 41 02 close 42 e0
window3 02 41 03 open 41 e0
window3 02 41 03 close 42 e0
window4 02 41 04 open 41 e0
window4 02 41 04 close 42 e0
```

```
# curtain1: east, curtain2: west, curtain3: north, curtain4: south
curtain1 02 42 01 open 41 e0
curtain1 02 42 01 close 42 e0
curtain2 02 42 02 open 41 e0
curtain2 02 42 02 close 42 e0
curtain3 02 42 03 open 41 e0
curtain3 02 42 03 close 42 e0
curtain4 02 42 04 open 41 e0
curtain4 02 42 04 close 42 e0
curtainA 02 42 ff open 41 e0
curtainA 02 42 ff close 42 e0
```

```
# light
light 02 90 01 on 30 80
light 02 90 01 off 31 80
```



# Appendix B : User manual for TCSC system installation

The source code folder includes 5 sub folders:

- TCSC: source code of TCSC
- tempHumidServer: Temperature Humidity logger server
  - tempHumidLogger : Temperature Humidity logger program folder
  - tempHumidProvider: Temperature Humidity server handler folder
- rainWindSever: source code of wind rain logger server
  - rainLogger : rain logger program folder
  - WindLogger: wind logger program folder
  - rainWindProvider: rain wind server handler folder
- deviceClient: source code of device client module
- airConditioner: source code of air conditioner controller

TCSC system has total 4 servers : Temperature Humidity logger server, wind rain logger server, device client module, air conditioner controller that serving the request of TCSC. TCSC, device client module, air conditioner controller are installed in the same physical server while Temperature Humidity logger server, wind rain logger server is in others servers. Notice that, except the TCSC program, all others servers and modules must be installed in the Linux environment.

## ❖ Install TempHumidity logger server

- Create a temperature humidity sensor network with the coordinator connects to server by the USB cable
- Copy all files of tempHumidServer folder to server that connects with the temperature humidity sensor
- Run the temperature humidity logger program
- Change the directory path to tempHumidLogger folder
- Use command to run : `./SensorLogger.py -s /dev/ttyUSB0 log.csv`
- Compile and run the temperature Humidity server program
  - Change the directory path to tempHumidProvider folder
  - Compile the program: `javac Provider.java`
  - Run the temperature Humidity server handler program: `java Provider 10000`
  - With 10000 is port number of server handler

## ❖ Install windRain logger server

- Copy all files of rainWindSever folder to server that connects with the win sensor and rain sensor
- Compile and Run wind logger program
  - Change the directory path to windLogger folder
  - Compile : `make`
  - Run : `make run`
- Compile and Run the rain logger program
  - Change the directory path to rainLogger folder
  - Compile: `make`

- Run : make run
- Compile and run the wind rain server handler program
  - Change the directory path to rainWindsever folder
  - Compile : javac RainWindDataProvider.java
  - Run program: java RainWindDataProvider
- ❖ Install device client module
  - Copy all files deviceClient folder to TANS2A server
  - Change the directory path to deviceClient folder
  - Run device client program : python ./echoCIntDuy2.py -c tans2.conf
  - Install air conditioner controller
  - Copy all files airConditioner folder to TANS2A server
  - Change the directory path to airConditioner folder
  - Compile air conditioner controller program : gcc -o cserver.c cserver
  - Run air conditioner controller program : ./cserver

❖ Install and set up TCSC

**Set up TCSC program**

- Configure the ip server address :
  - Configure ip and port tempHumid server : set ip value to thermal.sensorServerAddress property, set port value to thermal. deviceServerPort property
  - Configure ip and port rainWind server: set ip value to thermal.sensorServerAddress property : set ip value to RainWindDataRequester.serverAddress property, set port value to RainWindDataRequester.serverPort property
  - Configure ip and port device server: : set ip value to Aircon.deviceServerAddress property, set port value to thermal. deviceServerPort property
  - Configure ip and port air conditioner: set ip value to Aircon.deviceServerAddress property, set port value to Aircon.sensorServerPort
- Configure NCI NET logger file path : change the path where want to store the NCI NET logger file in the constructor function of Thermal class

```

public Thermal() {
    inNCILogger = new MyLogger("csv/%s_inNCI.csv", "# Time NET");
    outNCILogger = new MyLogger("csv/%s_outNCI.csv", "# Time NET");
    inNETLogger = new MyLogger("csv/%s_inNET.csv", "# Time NET");
}

```

Figure 27: the constructor function of Thermal class

- Copy all files TCSC folder to TANS2A server
- Compile TCSC program: javac Thermal.java
- Run TCSC program: java Thermal