

Title	Iterative Spatial Demapping for Simultaneous Full Data Exchange in Three-way Relaying Channels
Author(s)	Anwar, Khoirul; Matsumoto, Tad
Citation	The 3rd COST IC-1004 Meeting: 1-5
Issue Date	2012-02
Type	Presentation
Text version	author
URL	http://hdl.handle.net/10119/10896
Rights	Copyright (C) 2012 Athors. Khoirul Anwar and Tad Matsumoto, "Iterative Spatial Demapping for SimultaneousFull Data Exchange in Three-way Relaying Channels",The 3rd COST IC-1004 Meeting, 2012, 8-10 February 2012, Barcelona, Spain.
Description	3rd MC and Scientific Meeting, 8-10 February 2012, Barcelona, Spain.

EURO-COST

SOURCE: School of Information Science,
Japan Advanced Institute of Science and Technology
(JAIST), 1-1 Asahidai, Nomi-shi, Ishikawa, JAPAN
923-1292

**Iterative Spatial Demapping for Simultaneous
Full Data Exchange in Three-way Relaying Channels**

Khoirul Anwar and Tad Matsumoto
School of Information Science,
Japan Advanced Institute of Science and Technology (JAIST),
1-1 Asahidai, Nomi-shi, Ishikawa,
JAPAN 923-1292
Phone: +81-(0)761-51-1268
Fax: +81-(0)761-51-1149
Email: {anwar-k, matumoto}@jaist.ac.jp

Iterative Spatial Demapping for Simultaneous Full Data Exchange in Three-way Relaying Systems

Khoirul Anwar* and Tad Matsumoto*,**

*Japan Advanced Institute of Science and Technology (JAIST), 1-1 Asahidai, Nomi, Ishikawa, 923-1292 JAPAN

Email:{anwar-k, matumoto}@jaist.ac.jp

**Center for Wireless Communications, University of Oulu, FI-90014 Finland

Email: tadashi.matsumoto@ee.oulu.fi

Abstract—This TD presents an iterative spatial demapping (ISM) for simultaneous full data exchange in three-way relaying systems where there is no direct link between the users. Based on *a priori* knowledge provided by the decoders, ISM demapper makes it possible for the three users to exchange information simultaneously within only two phase transmissions by help of a relay. In the first phase, each user transmit simultaneously, while at the second phase, the relay amplify-and-forward the received composite signals to each user. The performances are evaluated by computer simulations in additive white Gaussian noise (AWGN) and frequency-flat Rayleigh fading channels. Bit-error-rate (BER) performance results show that clear turbo cliff is achieved at each user’s transmit power of 2.38 dB in AWGN channel (for each user). Extrinsic information transfer (EXIT) chart-based analysis are also presented to evaluate the convergence property of the iterative decoding algorithm. The proposed structure is simple since each transmitter consists of 2-state rate-1 doped accumulator as an inner encoder and short memory convolutional code (CC) as the outer encoder. Since the proposed technique is also spectrally efficient (because only two phase transmission is used for three users), its application includes future conferencing multi-way relaying systems where energy and computational complexity are of significant important.

I. INTRODUCTION

Development of portable wireless devices enable conference calls in which each user in a group is interested in sending and receiving data to and from all members in the groups is needed, for example, by emergency team in a disaster site. The similar situation happens between satellite and users on the earth, where the coverage and quality of the direct link is limited from the satellite to the users. To increase spectrum efficiency and extend the coverage, a practical solution is to introduce relay terminals. This terminal is critical especially when each user does not have direct link to other users or the satellites.

Studies on cooperative transmission for multiple users with the help of a relay have been presented, for example, in [1] where it is stated that feedback is still beneficial in multiuser multiway relay channel and its output is common for each user. Ref. [2] studies the theoretical analysis where the relay has its own message for each user, while in [3] the practical iterative decoding technique is proposed by assuming that the direct link between the users is available. In [4], three dimensional network coding scheme is proposed for three-way relay channels by considering fairness among the users.

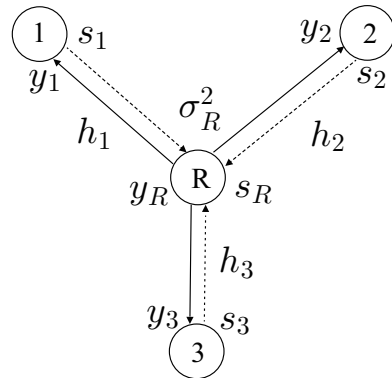

Fig. 1. Full data exchange in three-way relay systems with only two phase transmissions: (1) Phase 1: MAC channel (dashed lines), (2) Phase 2: Broadcast Channel (solid lines)

Many literatures assume that each user transmit their messages in different time slots, where the scheduling and multiple time slots are needed to avoid multiple access interference (MAI) [5]. With the insight from [6], in this work, we focus on full data exchange in three-way relay channels where all users simultaneously transmit their information to the relay (Phase 1) and the relay, broadcast their message as common output of the three-way relay channel (Phase 2).

II. SYSTEM MODEL

We focus on single carrier signalling transmission. Fig. 2 shows the system model considered in this TD. During Phase 1, each user transmits message $s_i, i \in \{1, 2, 3\}$ simultaneously as indicated by dashed line. The relay (R) amplify-and-forward (AF) the message from each user and broadcast s_R to all users during Phase 2 as indicated by solid line.¹

In this TD, we assume the messages s_1, s_2, s_3 are all in binary phase shift keying (BPSK) modulated symbol with $\mathbb{E}[s_1] = \mathbb{E}[s_2] = \mathbb{E}[s_3] = 1$. The channels coefficient between users and relay, h_1, h_2, h_3 , are assumed to be known to the receiver only in each phase but the phase difference $\theta = \angle(h_i, h_{\bar{i}})$ is assumed to be unknown, where $i \in \{1, 2, 3\}$ and $i \neq \bar{i}$.

The received signal at the relay is expressed as

$$y_R = h_1 s_1 + h_2 s_2 + h_3 s_3 + \sigma_r^2, \quad (1)$$

¹The relay does not have its own message in s_R .

where σ_r^2 is the noise variance at the relay. The relay amplify-and-forward the received signal y_R to each user with amplification/scaling factor G as

$$y_i = Gy_R + \sigma_i^2, \quad (2)$$

with y_i and σ_i^2 being the received signal and noise variance at the i -th destination, $i \in \{1, 2, 3\}$. Each user knows G and possible to subtract from its own signal so that the received signal at each i -th user is expressed as

$$\begin{aligned} y_i &= Gy_R - Gs_i + \sigma_i^2, \\ &= G \sum_{n=1, n \neq i}^3 s_n + (G+1)\sigma_i^2. \end{aligned} \quad (3)$$

By assuming that each user transmit with the same power $P_1 = P_2 = P_3 = P$, $\sigma_1^2 = \sigma_2^2 = \sigma_3^2 = 1$, and power of relay does not exceed P_r , we can re-express the scaling factor G as

$$G = \sqrt{\frac{P_r}{y_R}}, \quad (4)$$

$$= \sqrt{\frac{P_r}{3P+1}} \quad (5)$$

with the signal-to-noise power ratio (SNR) γ being

$$\begin{aligned} \gamma &= \frac{G^2(2P)}{(G^2+1)}, \\ &= \frac{2PP_r}{3(P+1)} \end{aligned} \quad (6)$$

III. PROPOSED DECODING STRATEGY

A. Source

Our proposed decoding strategy for three-way relay systems is shown in Fig. 2. Three sources b_1, b_2 , and b_3 are transmitted from three separated single antenna simultaneously. The bitstream b_i is convolutionally encoded using C_i , interleaved by Π_i , doped accumulated, and BPSK-modulated to produce BPSK symbol s_i .

The rate-1 doped accumulator (D-ACC) [7] is applied to support convergence tunnel until a point very close to (1,1) mutual information point. As shown in Fig. 2, D-ACC is performed after the interleaver Π_i . The structure of D-ACC is very simple since it is composed of a memory-1 systematic recursive convolutional codes (SRCC) with octal code generator of $([3, 2]_3)_8$ followed by *heavy puncturing* of the coded bits such that *coding rate* = 1. With a doping rate $P_A = P_B = P_C = 15$ for user 1, 2, 3, respectively, the D-ACC replaces every 15-th systematic bits with the accumulated coded bit.

At the receiver D-ACC decoding, denoted as D_{dacc} , is performed using Bahl-Cokce-Jelinek-Raviv (BCJR) algorithm [8] immediately after the equalization. It should be noted here that interleaver between D_{dacc} and the equalizer is not needed because the extrinsic log-likelihood ratio (LLR) is not exchanged between them.

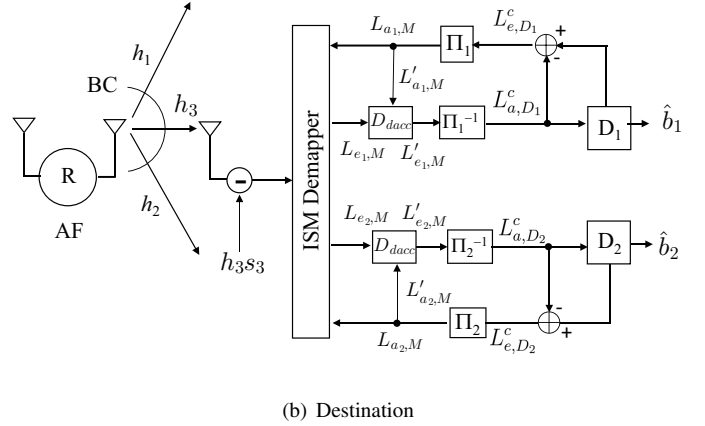
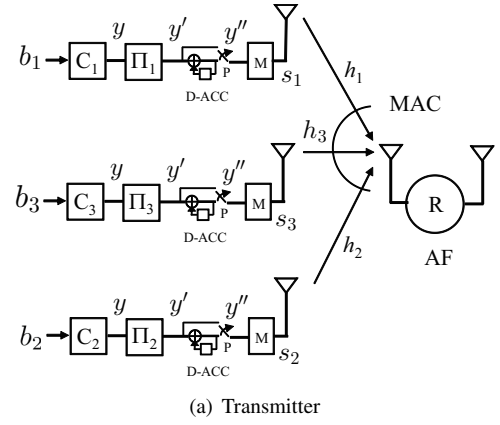

Fig. 2. The Proposed ISM Demapping for simultaneous full data exchange in three-way relay systems

B. Destination

The destination consists of a common ISM demapper, and two independent turbo loops because two sources are to be detected. ISM demapper performs demapping of spatial constellation from y_i with the help of *a priori* information in the form of LLR provided by the decoder. The demapper output is extrinsic LLR which is then fed into D_{dacc} , deinterleaved, and then decoded by the decoder D_i .

C. ISM Demapper

Let's consider, for example, user 3. As shown in Fig. 2(b), with the help of *a priori* information about s_1 provided by the decoder D_1 in the form of $L_{a_1, M}$, the demapper calculates the extrinsic LLR $L_{e_2, M}$ of the symbol s_2 from the received signal r by

$$\begin{aligned} L_{e_2, M} &= \ln \frac{\Pr(s_2 = +1|r)}{\Pr(s_2 = -1|r)} \\ &= \ln \frac{\sum_{s \in S_{+1}} \exp \left\{ -\frac{|r - h_1 s_1 - h_2 s_2|^2}{\sigma_n^2} + b_1 L_{a_1, M} \right\}}{\sum_{s \in S_{-1}} \exp \left\{ -\frac{|r - h_1 s_1 - h_2 s_2|^2}{\sigma_n^2} + b_1 L_{a_1, M} \right\}}, \end{aligned} \quad (7)$$

where \mathcal{S}_{+1} , \mathcal{S}_{-1} are the sets of superposition symbols having symbol s_1 being $+1$ and -1 , respectively, with $s_1 = 1 - 2b_1$. Similarly, with the help of *a priori* information about symbol s_2 provided by decoder D_2 in the form of $L_{a_2,M}$, the extrinsic LLR $L_{e_1,M}$ of symbol s_1 is given by

$$L_{e_1,M} = \ln \frac{\Pr(s_1 = +1|r)}{\Pr(s_1 = -1|r)}$$

$$= \ln \frac{\sum_{s \in \mathcal{S}_{+1}} \exp \left\{ -\frac{|r - h_1 s_1 - h_2 s_2|^2}{\sigma_n^2} + b_2 L_{a_2,M} \right\}}{\sum_{s \in \mathcal{S}_{-1}} \exp \left\{ -\frac{|r - h_1 s_1 - h_2 s_2|^2}{\sigma_n^2} + b_2 L_{a_2,M} \right\}}, \quad (8)$$

with $s_2 = 1 - 2b_2$.

The extrinsic LLRs, $L_{e_1,M}$ and $L_{e_2,M}$, are then used in doped deaccumulator D_{dacc} , deinterleaved by Π_1^{-1} and Π_2^{-1} , respectively, to provide *a priori* LLR, L_{a,D_1}^c and L_{a,D_2}^c , of the coded bits for the decoders D_1 and D_2 . This algorithm also applies for users 1 and 2.

IV. PERFORMANCE EVALUATION AND ANALYSIS

A. EXIT Analysis

This section describes EXIT analysis [9] to observe the convergence properties of the proposed iterative spatial demapper and its corresponding decoders with VI loops for some correlation p values. Fig. 3 shows at destination 3 the source b_1 EXIT chart of the ISM demapper and the decoder (by VI loop) for $P = 2.5$ dB and $h_1 = h_2 = 1 = h_3 = 1$.

The X-axis is mutual information (MI) for *a priori* LLR $I_{a_1,M} = I(x''; L'_{a_1,M})$ and extrinsic LLR $I_{e,D_1}^c = I(x; L_{e,D_1}^c)$, where x and x'' are shown in Fig. 2 and $L'_{a_1,M} = \Pi_1(L_{e,D_1}^c)$ with $\Pi_1(\cdot)$ being the Π_1 interleaver function. Here,

$$L_{a_1,M}(k) \equiv \begin{cases} L'_{a_1,M}(k), & k \neq nP_C, n = 1, \dots, K \\ 0, & \text{otherwise,} \end{cases} \quad (9)$$

where $L'_{a_1,M}(k)$ is the *a priori* LLR for D_{dacc} and k being the bit-index.

The decay of ISM demapper EXIT curve depends on each user's power P , the doping rate P_A, P_B, P_C , and the power at the relay P_r . For $P = 2.5$ dB and $P_A = P_B = P_C = 15$, Fig. 3 shows that higher power at the relay improves the performance as shown in the figure by lifting up the ISM demapper EXIT curve; among $P_r = \{1, 2, 3\}$ the ISM demapper EXIT curve is located at the highest place with $P_r = 3$ in the EXIT chart that makes the convergence tunnel open until a point very close to (1,1) mutual information point.

B. BER Performance

Bit-error-rate performance is evaluated in two conditions: (a) AWGN channel with random phase difference θ (equivalent to Rayleigh fading channel with instantaneous power control) and (b) 1-path block Rayleigh fading channel. The BER results in AWGN channel are plotted in Fig. 4(a). It is confirmed from the figure that $P_r = 3$ provides a better BER performance.

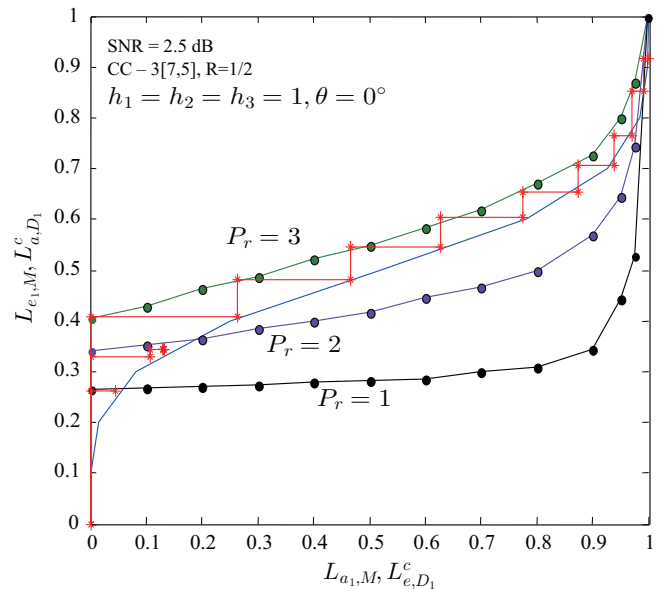

Fig. 3. EXIT chart of ISM Demapper at $P = 2.5$ dB

The results in 1-path Rayleigh fading channel shows that the average BER is slightly shifted from the theoretical QPSK BER curve. The reason is in three-way relay, the phase difference θ can not be controlled to be always orthogonal as in QPSK, when $\theta = 0$ and channel amplitude is the same, it results in received constellation $\{-2, 0, 2\}$.

V. CONCLUSIONS

A simple iterative spatial demapping (ISM) technique is proposed for simultaneous full data exchange in three-way relaying systems. Based on the *a priori* log-likelihood ratio (LLR) provided by the decoder, the ISM demapper can distinguish the simultaneously transmitted information, which allows the three users to exchange information simultaneously within only two transmission phases. Our BER performance results as well as EXIT chart analysis show that the performance in AWGN channel (or Rayleigh fading with instantaneous power control) has clear turbo cliff when each user's transmit power $P = 2.38$ dB with noise variance $\sigma_R^2 = \sigma_i^2 = 1, i \in \{1, 2, 3\}$. The results of average BER performance in block Rayleigh fading channel show that the performance of simultaneous full data exchange in three-way relaying systems is slightly shifted from the theoretical performance of QPSK because of the phase ambiguity.

REFERENCES

- [1] K. Eswaran and M. Gastpar, "Achievable rates for conferencing multiway channels," in *IEEE International Symposium on Information Theory (ISIT)*, Toronto, Canada, July 2008.
- [2] D. Gündüz, O. Simeone, A. Goldsmith, H. V. Poor, and S. Shamai, "Relaying simultaneous multicast messages," in *IEEE Information Theory Workshop (ITW)*, Italy, October 2009.
- [3] O. Iscan, I. Latif, and C. Hausl, "Network coded multi-way relaying with iterative decoding," in *IEEE International Symposium on Personal, Indoor, Mobile and Radio Communications (PIMRC)*, Istanbul, Turkey, September 2010, pp. 482–487.

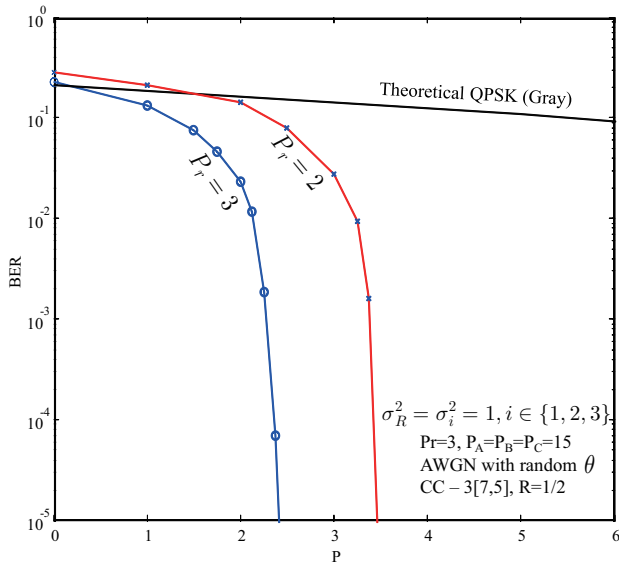

(a) BER for each user AWGN channel with random θ

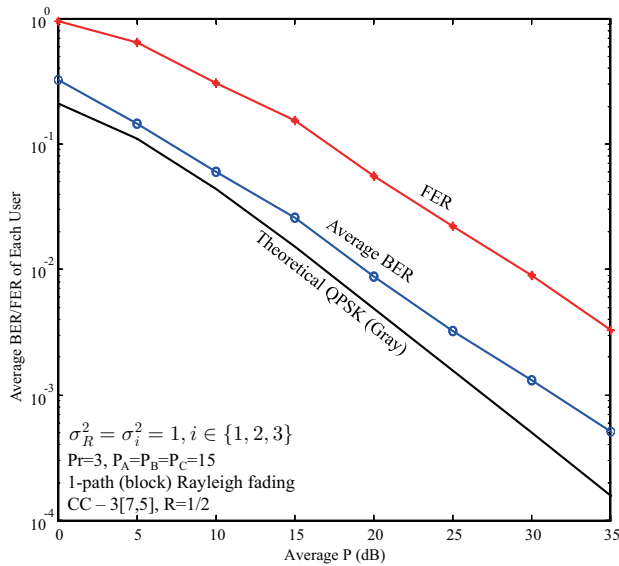

(b) Average BER/FER for each user in 1-path (block) Rayleigh fading channel

Fig. 4. BER performances

- [4] M. Park and S. K. Oh, “An iterative network code optimization for three-way relay channels,” in *IEEE Vehicular Technology Conference (VTC)-Fall*, Anchorage, AK, Sept. 2009.
- [5] Y. Jeon, Y.-T. Kim, M. Park, and I. Lee, “Opportunistic scheduling for three-way relay systems with physical layer network coding,” in *IEEE Vehicular Technology Conference (VTC)-Spring*, Budapest, Hungary, May 2011 2011.
- [6] K. Anwar and T. Matsumoto, “Iterative spatial demapping for two correlated sources with power control over fading MAC,” in *IEEE Vehicular Technology Conference (VTC)-Spring*, Yokohama, Japan, May 2012, (Accepted).
- [7] S. Pfletschinger and F. Sanzi, “Error floor removal for bit-interleaved coded modulation with iterative detection,” *IEEE Trans. on Wireless Communications*, vol. 5, no. 11, pp. 3174–3181, Nov. 2006.
- [8] L. Bahl, J. Cocke, F. Jelinek, and J. Raviv, “Optimal decoding of linear codes for minimizing symbol error rate,” *IEEE Trans. on Info. Theory*, vol. IT-20(2), pp. 284–287, March 1974.
- [9] S. ten Brink, “Convergence behavior of iteratively decoded parallel