

Title	Joint Source-Channel Decoding for LDPC-coded Error-Corrupted Binary Markov Sources
Author(s)	Zribi, Amin; Matsumoto, Tad; Pyndiah, Ramesh
Citation	2016 International Conference on Computing, Networking and Communications (ICNC): 1-6
Issue Date	2016-02
Type	Conference Paper
Text version	author
URL	http://hdl.handle.net/10119/13492
Rights	This is the author's version of the work. Copyright (C) 2016 IEEE. 2016 International Conference on Computing, Networking and Communications (ICNC), 2016, 1-6. Personal use of this material is permitted. Permission from IEEE must be obtained for all other uses, in any current or future media, including reprinting/republishing this material for advertising or promotional purposes, creating new collective works, for resale or redistribution to servers or lists, or reuse of any copyrighted component of this work in other works.
Description	



Joint Source-Channel Decoding for LDPC-coded Error-Corrupted Binary Markov Sources

Amin Zribi^{*§}, Tad Matsumoto^{||} and Ramesh Pyndiah[§]

^{*}Tunis Elmanar University, National Engineering School of Tunis, SysCom laboratory, BP 37, Le Belvedere, 1002, Tunis
Email: amin.zribi@isetcom.tn

^{||} Japan Advanced Institute of Science and Technology, 1-1 Asahidai, Nomi, Ishikawa, Japan,
and Centre for Wireless Communications (CWC), University of Oulu, Finland (Part-time)

Email: matumoto@jaist.ac.jp

[§]Institut Télécom, Télécom Bretagne, Lab-STICC UMR CNRS 6285, Technopole Brest Iroise, CS 83818, Brest, France,
and Université européenne de Bretagne

Email:ramesh.pyndiah@telecom-bretagne.eu

Abstract—We consider the problem of joint decoding and data fusion in data gathering for densely deployed sensor networks modeled by the Chief Executive Officer (CEO) problem. More specifically, we consider the binary CEO problem where all sensors observe the same time-correlated binary Markov source corrupted by independent binary noises. Hence, the observations are two-dimensionally (temporary and spatially) correlated. In the proposed scheme, every sensor apply a low-density parity-check (LDPC) code and transmit the corresponding codeword independently over additive white Gaussian noise (AWGN) channels. To reconstruct the original bit sequence, an iterative joint source-channel decoding (JSCD) technique is considered. To exploit the knowledge about the source correlations, we consider an iterative decoding between a sum-product (SP) decoder serially concatenated with BCJR decoder which is applied for every sensor as local iterations. Then, correlation between sensors' data is employed to update extrinsic information received from the SP-BCJR decoders of the different sensors during global iterations. We illustrate the performance of the joint decoder for different correlation setups and with different number of sensors. Simulation results, in terms of bit error rate show promising improvements compared with the separate decoding scheme where the correlation knowledge is not completely utilized in the decoder.

I. INTRODUCTION

During the last years, and with the advances of hardware and wireless technologies, the scientific community showed a growing research interest in Wireless Sensor Networks (WSNs) [1]. Many data gathering WSNs applications such as environmental and structural monitoring, remote sensing, and precision farming deploy a large number of sensors to collect useful information in the sensing fields of interest. Each sensor independently encodes its measurement, and then send through rate-constrained channel to a single fusion center (FC) for further processing. However, such an architecture may induce some unreliable components since (1) sensors sample their field of interest with noisy, error-prone transducers, and (2) the sensed information is communicated to the FC over unreliable wireless links. The ultimate goal for the FC is to outstrip these constraints to deliver the best estimate on the sensed information with reasonable fidelity. This type of WSNs architecture can be modeled by the CEO problem

[2] where a CEO is interested in a source information that he cannot observe directly, so deploys M agents to obtain different versions that he can use to provide the best estimate on the source information.

Theoretical performance bounds corresponding to source coding under rate constraints for the CEO problem were first proposed by Berger [3] and Tung [4]. In fact, they characterized the inner and outer bounds on the information rate to achieve the acceptable distortions. The quadratic Gaussian CEO problem where two sources uses Gaussian codebook for source coding and the observations are, hence, jointly Gaussian distributed was studied in [5]. Determining the performance bounds of CEO problem remains, in many cases, still open question to this date.

The data gathering densely deployed WSNs setup includes some remarkable properties. First, the nature of the sensed physical phenomena imposes a memory structure in the source information that we call *temporal correlation*. Joint source-channel (JSC) coding methods can exploit such a characteristic to improve the performance with respect to a separated approach. First methods in this context consider an entropy-achieving source encoder, and a channel decoder exploiting the residual redundancy [6], [7]. Otherwise, several JSC techniques [8]–[10] focused on exploiting the whole correlation in the decoding process, without using source compression, to simplify the encoder structure and reduce power consumption which is more convenient for WSNs. Second, the signals forwarded by the multiple sensors are highly correlated since the data to be delivered to the FC are generated by the same originator, we call this dependency *spatial correlation*. In an attempt to exploit this correlation, many recent works [11], [12] focused on proposing distributed source coding methods that approach the Slepian-Wolf limit [13]. JSC coding is also an alternative solution that can be considered when the spatial correlation is not compressed (to reduce the encoder complexity) but is exploited at the decoder to jointly recover the source information with a better reliability. In the last decade, the design of practical iteratively decodable JSC schemes exploiting the correlations within WSNs motivated a lot of at-

tention. Different concatenated codes were considered in many recent contributions such as BCH and LDGM codes in [14], irregular repeat-accumulate (IRA) in [15], a concatenation of convolutional code and doped-accumulator in [16], and Turbo-codes in [17]. In this paper, we propose to use LDPC codes and to exploit their graphical representation to apply iterative JSC decoding. A theoretical expression relating the system capacity to the number of sensors and system parameters was derived in [18] for the CEO problem. In the cited references, it was shown that iteratively applying JSC decoding performs better than separated decoding when the spatial correlation is exploited. However, relatively low attention has been given to the temporal correlation exploitation.

In this paper, we suppose the source is correlated in space and time domains, hence its entropy is not fully saturated, and we aim at demonstrating how exploiting such memory structures at the destination is effective in reducing the traffic load and hence transmit power. We focus on a stationary, ergodic, two-state emitting binary first-order Markov source, and consider M sensors observing independent noisy versions of the source information. The observation error at every forwarding node is presented with a bit-flipping model with some error probability. We also suppose that the different sensors cannot cooperate to exploit their spatial correlation. Thus, every node encodes separately his observation using an LDPC code and forwards the corresponding codeword to the FC. We assume that the encoded sequences from sensors are transmitted through independent additive white Gaussian noise (AWGN) channels. The FC tries to estimate the source information sequence based on the different noisy signals from the sensors and by exploiting both spatial and temporal correlations. With this aim, we propose an iterative message passing JSC decoding method that can be divided into two main processes. In the first process, observations coming from the different sensors are decoded independently. Each decoder applies JSC iterative decoding based on extrinsic information exchange between the sum-product (SP) LDPC decoder and a MAP decoder exploiting the temporal correlation. The second process, aims to recover an estimate of the source information, common to all the observations, by exploiting the spatial correlation. Such task is performed using a Log-likelihood ratio (LLR) updating function between the component decoders with the successive sensors.

This paper is structured as follows. In Section II, notations and preliminaries on the system model are provided. In Section III, we formulate the proposed message passing algorithm for JSC decoding and data fusion which well utilizes the correlation knowledge in the case of LDPC-coded binary Markov sources. Simulation results and discussions are provided in Section IV. Finally, Section V concludes the paper.

II. SYSTEM MODEL

Figure 1 depicts the binary CEO model for a data-gathering WSN scheme investigated in this paper. M sensors are deployed to observe the sensing target. Such an architecture can model many real-life applications like video surveillance,

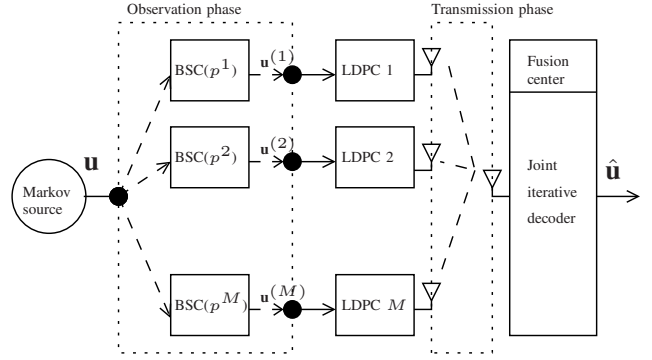

Fig. 1. A sensor network with binary CEO model. \mathbf{u} is a sequence generated by the two-states binary Markov source. For each sensor $m \in \{1, \dots, M\}$, vector $\mathbf{u}^{(m)}$ is the observation of \mathbf{u} through the binary-symmetric channel (BSC) modeling the observation error with probability $p^{(m)}$. The sensors encode their observations using an LDPC code and transmit the resulting codewords to the FC through independent AWGN channels. The decoder fuses the M sequences together and delivers an estimate of \mathbf{u} as $\hat{\mathbf{u}}$.

precision agriculture, industrial monitoring, etc. According to the dynamics that governs the physical behavior of the sensed phenomena, the source delivers temporally correlated data, and a Markov process can be used to model the source-memory. In the following, we describe the source as a two-state binary first-order Markov source $\{S_t\}$ defined by $\alpha = \Pr(S_t = 1|S_{t-1} = 0)$ and $\beta = \Pr(S_t = 0|S_{t-1} = 1)$, generating a sequence $\mathbf{u} = (u_1, \dots, u_K)$ of length K symbols. The memory structure of the source is fully characterized by α and β , with which $\alpha = \beta = 0.5$ indicates the memoryless source. The stationary distribution of the source states $\mu_0 = \Pr(S_t = 0)$, and $\mu_1 = \Pr(S_t = 1)$ are given by $\mu_0 = 1 - \mu_1 = \frac{\beta}{\alpha + \beta}$.

We can also distinguish the case of a symmetric source with memory where $\alpha = \beta \neq 0.5$ that defines equal stationary state probabilities $\mu_0 = \mu_1$. When $\alpha \neq \beta$, the source is called asymmetric and the source is correlated in time and has a non-uniform distribution of the source bits. In this paper, the cases of symmetric and asymmetric first-order Markov sources will be investigated. The entropy rate corresponding to the stationary binary Markov source is given by $H(S) = \mu_0 h(\alpha) + \mu_1 h(\beta)$, where $h(x) = -x \log_2(x) - (1-x) \log_2(1-x)$ denote the binary entropy function.

A set of M sensors observes the source information \mathbf{u} , subject to a probability of sensing error $p^{(m)} = \Pr(u_k^{(m)} \neq u_k)$ for $k \in \{1, \dots, K\}$, with $0 < p^{(m)} < 0.5$ for all $m \in \{1, \dots, M\}$. Thus, sensor number m receives a noisy observation of the source sequence as $\mathbf{u}^{(m)} = (u_1^{(m)}, \dots, u_K^{(m)})$ after passing through a binary symmetric channel (BSC) with crossover probability $p^{(m)}$. Each sensor encodes its data using a systematic irregular LDPC code with rate $R^{(m)}$. We suppose that the different sensor-encoders are not able to communicate with each other to directly exploit the correlation between their inputs. The coded sequence $\mathbf{b}^{(m)} = (b_1^{(m)}, \dots, b_N^{(m)})$ for sensor m consists of K information bits and $N - K$ parity bits. Finally, the obtained sensor codewords $\mathbf{b}^{(m)}$ are modulated by binary-phase shift keying (BPSK) and transmitted to the FC

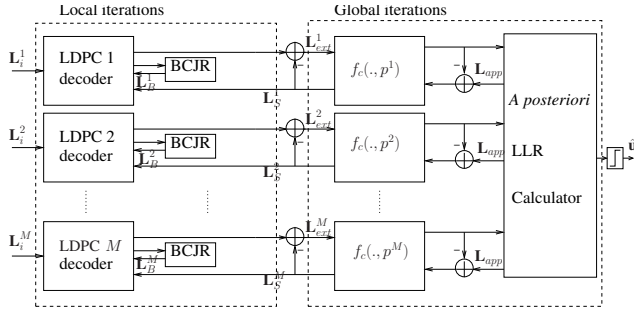

Fig. 2. The proposed JSC decoding strategy for a parallel sensor network exploiting both source temporal correlation and inter-sensors' spatial correlation. The algorithm follows iterative processing with local and global message passing steps. For each elementary decoder $m \in \{1, \dots, M\}$, the initial input is the channel intrinsic information $\mathbf{L}_i^{(m)}$, and the LDPC decoder exploits extrinsic information: $\mathbf{L}_B^{(m)}$ provided by the BCJR decoder, and $\mathbf{L}_S^{(m)}$ generated by the global iterations made by the *a posteriori* LLR calculator.

over independent AWGN channels. The FC aims to recover the original source information from the data sent by all sensors $\mathbf{y}^{(m)} = \mathbf{s}^{(m)} + \mathbf{n}^{(m)}$ for $m \in \{1, \dots, M\}$ where $\mathbf{s}^{(m)}$ is the BPSK modulated symbol sequence at sensor m , and $\mathbf{n}^{(m)}$ denotes a zero mean Gaussian noise with variance $(\sigma^{(m)})^2$.

In this contribution, we don't focus on theoretical aspects, and the main objective is to propose a practical FC joint decoder for the estimation of the source sequence $\hat{\mathbf{u}}$ by applying an iterative message-passing algorithm. The joint decoder applies its knowledge of both the correlation between sensors' data, and the temporal correlation induced by the source memory to update the extrinsic information during the iterative decoding process. In the following section, we present a method for applying such a decoding process for sensor networks equipped by LDPC codes.

III. JOINT DECODING AND DATA FUSION FOR LDPC-CODED BINARY MARKOV SOURCES

As mentioned, for complexity constraints, the WSN system model considered in this paper supposes no source compression, and no distributed processing. Thus, the design of the joint decoder that can best exploit the system correlation properties plays a very important role. In fact, in the proposed decoder the temporal and spatial correlations are exploited through two types of iterations: local and global iterations. As depicted in the block diagram of Fig. 2, during local iterations the systematic variable nodes of the LDPC Tanner graph of sensor number m receives the channel observations LLRs $\mathbf{L}_i^{(m)}$ as intrinsic information, the extrinsic information $\mathbf{L}_B^{(m)}$ delivered by a MAP source decoder using the BCJR algorithm [19] applied to the trellis diagram of the Markov source, and an extrinsic information $\mathbf{L}_S^{(m)}$ fusing all sensors data given by the last global iteration. The latter is equal to zero before the first global iteration. The LLRs are exchanged between the variable and check nodes of the LDPC, and the Markov source-graph on which BCJR is applied until a maximum number of local iterations is reached. Then a global iteration is performed to update the spatial corre-

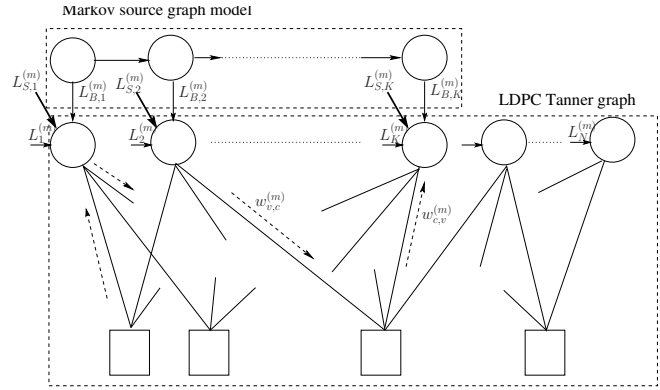

Fig. 3. The proposed JSC iterative message passing decoder and the messages exchanged between the variable and check nodes, the BCJR source decoder, and the data fusing LLR calculator. Iterations indices l and g are omitted for sake of clarity.

lation information using an LLR updating function taking into account the observation error probability $p^{(m)}$. During a global iteration, the *a posteriori* LLR calculator fuses all the information generated by the elementary local decoders to deliver a full *a posteriori* information \mathbf{L}_{app} . Each local decoder extracts its corresponding extrinsic information $\mathbf{L}_S^{(m)}$ that will be appended in the next local iteration to improve the system performance by exploiting the spatial correlation.

Let's focus on the information transfer between the different decoders for a sensor m , a local iteration number $l \in \{1, \dots, L\}$, and a global iteration $g \in \{1, \dots, G\}$. We denote $w_{v,c}^{(l,m)}$ and $w_{c,v}^{(l,m)}$ respectively the LLR messages passed from the v -th variable node to the c -th check node and inversely at the local iteration l for sensor m . For the initialization, the LLRs to be used for the global iteration are first set to zero for all decoders. The check-to-variable node messages are also initialized to zero for the first local iteration. We suppose that the LDPC codewords were transmitted by means of BPSK modulation through independent AWGN channels with zero-mean and $(\sigma^{(m)})^2$ noise variance. Then, the channel LLRs are first calculated for a sensor m according to the received signal $\mathbf{y}^{(m)} = (y_1^{(m)}, \dots, y_N^{(m)})$ by $L_v^{(m)} = 2y_v^{(m)}/(\sigma^{(m)})^2$ for $1 \leq v \leq N$. The process for the LLR message updating for a sensor m follow the SP decoding with additional LLRs from the BCJR decoder for every local iteration and from the other sensors' decoders for every global iteration.

As shown in Fig. 3, the LLR messages of the m -th sensor decoder to be forwarded from the systematic variable nodes to the corresponding check nodes exploit both source temporal and spatial correlations by respectively inducing the extrinsic LLR $L_{B,v}^{(l,m)}$ sent from the BCJR decoder to the variable node v and the updated LLR delivered by the other sensors $L_{S,v}^{(g-1,m)}$ at the previous global iteration. For $v \in \{1, \dots, K\}$, we have:

$$w_{v,c}^{(l,m)} = L_v^{(m)} + \sum_{c' \neq c} w_{c',v}^{(l,m)} + L_{B,v}^{(l,m)} + L_{S,v}^{(g-1,m)} \quad (1)$$

For parity variable nodes, we have no extra information to exploit, and the check messages update follows the standard

SP decoder with, for $v \in \{K + 1, \dots, N\}$:

$$w_{v,c}^{(l,m)} = L_v^{(m)} + \sum_{c' \neq c} w_{c',v}^{(l,m)} \quad (2)$$

In each local iteration, the input LLR of the BCJR decoder denoted $L_{v,B}^{(l,m)}$ is calculated by excluding his delivered information at the previous local iteration from the *a posteriori* LLR. Thus, we can write:

$$L_{v,B}^{(l,m)} = L_v^{(m)} + \sum_{c'} w_{c',v}^{(l,m)} + L_{S,v}^{(g-1,m)} \quad (3)$$

After L local iterations, the overall *a posteriori* LLR can be evaluated for every variable node to prepare the next global iteration, and for every local JSC decoder m we have

$$L_{v,app}^{(g,m)} = L_v^{(m)} + \sum_{c'} w_{c',v}^{(l,m)} + L_{B,v}^{(l,m)} + L_{S,v}^{(g-1,m)} \quad (4)$$

This information can be used for spatial correlation update in the next global iteration. In fact, after performing LDPC SP decoding several iterations, the *a posteriori* LLRs output from the M elementary decoders are combined. As described previously, the sequences processed at the different forwarding nodes are initially generated by the same originator, and corrupted by random errors with probabilities $p^{(m)}$ for $1 \leq m \leq M$. Since we suppose that the observation error probabilities are known, we can evaluate the contribution of node m to the LLR of the original sequence \mathbf{u} . It is quite straightforward that for every node m , we can obtain a relation between the probabilities of the v -th bits, u_v of \mathbf{u} and $u_v^{(m)}$ of $\mathbf{u}^{(m)}$ as:

$$\begin{aligned} \Pr(u_v = 1) &= (1 - p^{(m)})\Pr(u_v^{(m)} = 1) + p^{(m)}\Pr(u_v^{(m)} = 0) \\ \Pr(u_v = 0) &= (1 - p^{(m)})\Pr(u_v^{(m)} = 0) + p^{(m)}\Pr(u_v^{(m)} = 1) \end{aligned}$$

Based on these relations, we can demonstrate after several mathematical manipulations that the expression relating the LLRs of \mathbf{u} and $\mathbf{u}^{(m)}$ components can be written as:

$$\begin{aligned} L(u_v) &= \log \left(\frac{\Pr(u_v = 1)}{\Pr(u_v = 0)} \right) \\ &= \frac{(1 - p^{(m)}) \exp(L(u_v^{(m)})) + p^{(m)}}{p^{(m)} \exp(L(u_v^{(m)})) + (1 - p^{(m)})}, \end{aligned} \quad (5)$$

which is equivalent to the LLR updating function $f_c(L(u_v^{(m)}), p^{(m)})$ applied for $L(u_v^{(m)})$ given the error probability $p^{(m)}$ [20].

In our system, this function will be applied to extrinsic LLRs excluding the spatial correlation information of the previous global iteration. This extrinsic information will be delivered by every sensor as

$$L_{v,ext}^{(g,m)} = L_{v,app}^{(g,m)} - L_{S,v}^{(g-1,m)} \quad (6)$$

Then, we perform LLR update using $f_c(\cdot, p^{(m)})$, and sum up over all sensors to have

$$L_{v,app}^{(g)} = \sum_{m=1}^M f_c(L_{v,ext}^{(g,m)}, p^{(m)}) \quad (7)$$

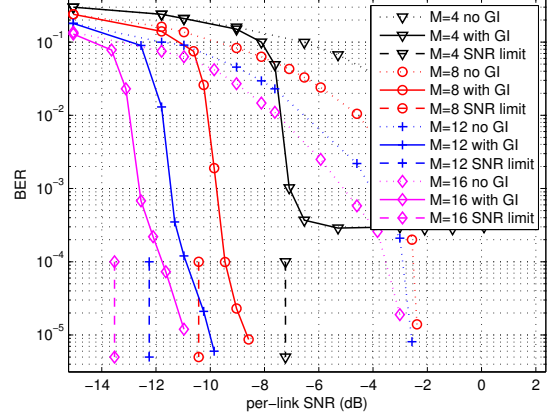

Fig. 4. BER performance of the proposed joint decoder exploiting only spatial correlation through global iterations (GI) between $M = \{4, 8, 12, 16\}$ forwarding nodes with observation error probability $p^{(m)} = 0.01$.

For every variable node v , and for every sensor m , we evaluate the *a priori* information coming from the global iteration as:

$$L_{S,v}^{(g,m)} = f_c(L_{v,app}^{(g)} - L_{v,ext}^{(g,m)}, p^{(m)}) \quad (8)$$

After that, novel local iterations are performed until the maximum number of global iterations G is reached.

Finally, the estimated message is obtained by taking the hard decision on the *a posteriori* LLR of all the variable nodes which is calculated as

$$L_v = \sum_{m=1}^M f_c(L_{v,app}^{(G,m)}, p^{(m)}). \quad (9)$$

IV. SIMULATION RESULTS

In this section, we present simulation results obtained by applying the proposed JSC decoding algorithm and compare them to theoretical bounds obtained without considering observation-errors.

A. Theoretical bounds

As mentioned above, the derivation of the theoretical bound for the CEO problem with a correlated source is difficult, and remains open. Instead, under the assumption of zero observation-error probabilities, the system will be equivalent to a parallel coding of a Markov source for which the derivation of the bound under separated source-channel coding assumption is feasible. In fact, according to [20], on the basis of the Shannon and the Slepian-Wolf theorems, the conditions for reliable communications of two correlated sources $S^{(1)}$ and $S^{(2)}$ over independent channels can be expressed as:

$$\begin{aligned} H(S^{(1)}|S^{(2)}) &< C_1/R_1 \\ H(S^{(2)}|S^{(1)}) &< C_2/R_2 \\ H(S^{(1)}, S^{(2)}) &< C_1/R_1 + C_2/R_2 \end{aligned} \quad (10)$$

where R_i is the rate of the channel code used for source S_i , and C_i is the capacity of the corresponding channel. In a CEO

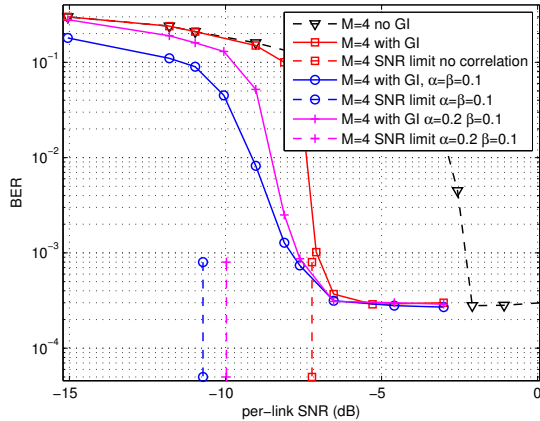

Fig. 5. BER performance of the proposed joint decoder exploiting temporal and spatial correlations between $M = 4$ forwarding nodes with observation error probability $p^{(m)} = 0.01$.

problem setup, we consider M sources and equation (10) can be generalized to

$$H(S^{(1)}, \dots, S^{(M)}) = H(\mathbf{S}) < \sum_{i=1}^M \frac{C_i}{R_i}. \quad (11)$$

Under the assumption that the links between the different forwarding nodes and the destination have the same AWGN properties with a signal-to-noise ratio SNR , and with equal channel encoding rates $R_i = R, \forall i \in \{1, \dots, M\}$, we can obtain:

$$H(\mathbf{S}) < M \frac{\log_2(1 + SNR)}{2R}, \quad (12)$$

Under the assumption that no errors occur at the observation phase, all the forwarding nodes will process the same source information, and the term $H(\mathbf{S})$ will be the original binary Markov source entropy rate $H(S)$ given in Section II, which means that

$$SNR_{\text{lim}} = 10 \log_{10} \left(2^{\frac{2H(S)R}{M}} - 1 \right). \quad (13)$$

B. Spatial correlation exploitation

In this paragraph, we investigate the bit error-rate (BER) system performance in the case where the source memory structure is not exploited. The objective is to show the gains induced by the global iterations (information exchange between the different LDPC SP decoders) and the effect of the number of the sensors on the global system performance. The observation error probabilities are supposed equal for all the sensors $p^{(m)} = 0.01$ and the source-sequence length is equal to $K = 2048$ bits. For all sensors, we used a rate $R = 0.5$ irregular LDPC code based on optimized degree distribution over AWGN channels [21]. The corresponding variable node degree distribution is given by $\lambda(x) = 0.25105x + 0.30938x^2 + 0.00104x^3 + 0.43853x^9$. The simulations were made for the case of $M = 4, 8, 12$, and 16 sensors with $G = 8$ global iterations and $L = 30$ local iterations.

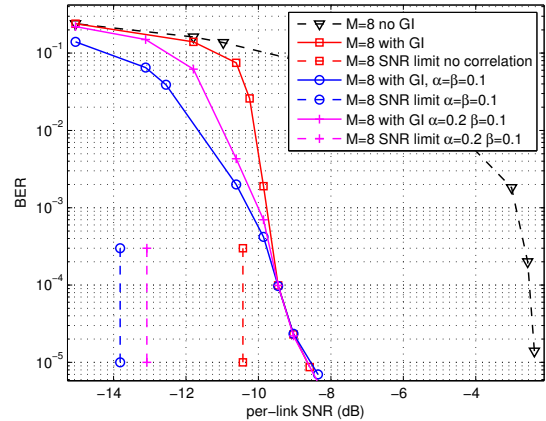

Fig. 6. BER performance of the proposed joint decoder exploiting temporal and spatial correlations between $M = 8$ forwarding nodes with observation error probability $p^{(m)} = 0.01$.

Fig. 4 illustrates the BER performances with respect to the per-link signal-to-noise ratio (SNR) for the cases where global iterations are performed for spatial correlation exploitation (solid curves) and when no global iterations are performed (dashed curves) and provides the corresponding theoretical limits. It is clear that the global iterations induce significant improvements in terms of per-link SNR. In fact, the exploitation of the spatial correlation between forwarding nodes involves a gain of about 4.75 dB when $M = 4$ sensors are used, and can achieve almost 8 dB when we have $M = 16$ sensors. Moreover, we can conclude that the achieved improvement is better when the number of sensors increases, and a gain of about 2.5 dB is obtained when we double the number from 8 to 16. When no global iterations are performed, this improvement is not so significant since the elementary local decoders work independently. The gap between theoretical limits and simulation results for the different values of M is low. In fact, for $M = 8$ and $M = 12$ we have a gap of about 1 dB and 1.25 dB respectively. We finally notice an error floor at a BER equal to $3 \cdot 10^{-4}$ when 4 sensors are used which is caused by the distortion included with the observation errors. This value depends only on the observation-error probabilities and on the number of sensors. To reduce the impact of such an error floor, the only solution is to increase the sensors number.

C. Effects of the exploitation of the source temporal correlation

In the previous sub-section, we demonstrated the possible improvements we can achieve by exploiting inter-nodes spatial correlation in the case of a memoryless source. The aim of this part is to investigate the proposed JSC iterative decoder performance in the case of a temporally-correlated source. As stated in the previous sections, the source is modeled as a state transition emitting Markov source. The source decoding is performed by applying the BCJR algorithm on its trellis diagram.

The BER curves of the different decoding methods with different correlation parameters are shown in Fig. 5 for $M = 4$ and in Fig. 6 for $M = 8$ forwarding nodes. We consider two types of binary Markov sources. The first is a symmetric one with $\alpha = \beta = 0.1$, and the second is asymmetric with $\alpha = 0.2$ and $\beta = 0.1$. It can be observed that with the exploitation of the temporal source correlation, the performance of the system can be improved for relatively high to medium noisy channel. It is found from Fig. 5, that for $M = 4$ sensors and with the asymmetric source, roughly gain of 1.0 dB can be achieved at a BER of 10^{-2} over the decoder that exploits only spatial correlation. This gain increases to approximately 1.5 dB for the symmetric source with $\alpha = \beta = 0.1$ which is more correlated (lower entropy). The gap between theoretical limits and simulation results for the proposed decoder with $\alpha = \beta = 0.1$ is about 3.1 dB, and for $\alpha = 0.2, \beta = 0.1$ is almost equal to 2.5 dB. It is found that the larger the temporal correlation, the larger the gap between theoretical limits and simulation results.

Moreover, in the case of 8 forwarding nodes, the improvement obtained through temporal correlation exploitation is also remarkable. As shown in Fig. 6, applying JSC decoding involves a gain of about 2 dB for a BER equal to 10^{-2} and when $\alpha = \beta = 0.1$, which correspond to an overall 7.5 dB SNR gain compared to a separated approach. This gain reduces to almost 7 dB for the asymmetric case with $\alpha = 0.2$ and $\beta = 0.1$. However, as for $M = 4$ sensors, the joint source decoding gain is lost for low error rates. Compared to the theoretical limits, we can see that the gap is increasing when the temporal correlation level increases.

V. CONCLUSION

In this paper, we considered JSC decoding and data fusion for sensor networks using LDPC codes. The proposed decoder first aims at exploiting the knowledge of temporal correlation in the data delivered by a binary Markov source to apply iterative JSC decoding based on the BCJR algorithm with SP decoding. The proposed scheme is also exploiting the spatial correlation between sensor's data at the fusion center. In fact, global iterations are made based on the update of the extrinsic information received from the joint iterative elementary sensors' decoders. We show how messages are passed between the LDPC variable nodes, check nodes, and the BCJR decoder during local iterations and between the M sensors' decoders during global iterations. The performance of the proposed decoder are evaluated for systems modeled by binary CEO problem. Our simulation results emphasize the major improvements due to the exploitation of temporal source correlation and the spatial correlation. The results show that making global iterations can increase the system performance by inducing a gain of about 7.5 dB in per-link SNR when 8 sensors are forwarding the information. It was also shown that exploiting the source memory in the decoding process involves remarkable improvements for relatively low-to-medium SNRs.

Finally, we can conclude that since densely deployed wireless networks induce remarkable correlation levels in time and

space with a non saturated entropy, exploiting the source and system memory structures through iterative JSC decoding and data fusion is an effective solution in improving the system performance.

ACKNOWLEDGMENT

This research is in part supported by the EU FP7 RESCUE project, in part Academy-of-Finland NETCOBRA project, and JSPS Kakenhi (B) 15H04007.

REFERENCES

- [1] B. Krishnamachari, *Networking Wireless Sensors*, Cambridge University Press, 2005.
- [2] T. Berger, Z. Zhang, and H. Viswanathan, "The CEO problem", *IEEE Trans. on Inf. Theory*, vol. 42, no. 3, pp. 887-902, May 1996.
- [3] T. Berger, "Multiterminal source coding," in *The Information Theory Approach to Communications*, vol. 229 (CISM Courses and Lectures), G. Longo, Ed. New York: Springer-Verlag, pp. 171231, 1978..
- [4] S.-Y. Tung, "Multiterminal Source Coding," Ph.D. dissertation, Cornell University, 1978.
- [5] Y. Oohama, "The rate-distortion function for the quadratic Gaussian CEO problem," *IEEE Trans. Inform. Theory*, vol. 44, no. 3, May 1998.
- [6] X. Jaspas, C. Guillemot, and L. Vandendorpe, "Joint sourcechannel turbo techniques for discrete-valued sources: from theory to practice", *Proc. of the IEEE*, vol. 95, no. 6, pp. 1345-1361, 2007.
- [7] A. Zribi, R. Pyndiah, S. Zaibi, F. Guilloud, and A. Bouallgue, "Low-complexity soft decoding of Huffman codes and iterative joint source/channel decoding", *IEEE Trans. comm.*, vol. 60, no. 6, Jun. 2012.
- [8] H. Belhadj, S. Zaibi, and A. Bouallegue, "Iterative joint source-channel decoding with source statistics estimation: application to image transmission", *Signal Processing for Image Enhancement and Multimedia Processing*, Springer, pp. 301-311, 2008.
- [9] M. A. Mohd Izhar, N. Faisal, X. Zhou, K. Anwar, and T. Matsumoto, "Exploitation of 2D binary source correlation using turbo block codes with fine-tuning", *EURASIP Journal on Wireless Communications and Networking* vol. 2013, no. 1, pp. 1-11, 2013.
- [10] R. Asvadi, T. Matsumoto, and M. J. Juntti, "Optimized LDPC codes for joint source-channel decoding of quantized Gauss-Markov signals", in *2014 IEEE International Conference on Communications (ICC)*, pp. 5233-5238, 2014.
- [11] J. Bajcsy, and P. Mitran, "Coding for the Slepian-Wolf problem with turbo codes", *IEEE Globecom*, vol. 2, San Antonio, TX, USA, 2001.
- [12] Z. Xiong, A. D. Liveris, and S. Cheng, "Distributed source coding for sensor networks", *IEEE Signal Proc. Mag.*, vol. 21, no. 5, 2004.
- [13] D. Slepian, and J. K. Wolf, "Noiseless coding of correlated information sources", *IEEE Trans. Inf. Theory*, vol. 19, no. 4, pp. 471-480, Jul 1973.
- [14] J. Del Ser, D. Manjarres, P. M. Crespo, S. Gil-Lopez, and J. Garcia-Frias, "Iterative fusion of distributed decisions over the Gaussian multiple-access channel using concatenated BCH-LDGM codes", *EURASIP Journal on Wireless Communications and Networking*, vol. 2011, 2011.
- [15] W. Zhong, and J. Garcia-Frias, "Combining data fusion with joint source-channel coding of correlated sensors using IRA codes", in *Proc. of the Conf. on Information Sciences and Systems*, 2005.
- [16] X. He, X. Zhou, K. Anwar, and T. Matsumoto, "Estimation of observation error probability in wireless sensor networks", *IEEE Communications Letters*, vol. 17, no. 6, pp. 1073-1076, June 2013.
- [17] J. Haghghat, H. Behroozi, and D. V. Plant, "Joint decoding and data fusion in wireless sensor networks using turbo codes", In *IEEE 19th Intl. Symp. PIMRC*, pp. 1-5, 2008.
- [18] A. Razi, K. Yasami, and A. Abedi, "On minimum number of wireless sensors required for reliable binary source estimation", In *IEEE Wireless Communications and Networking Conf.*, 2011, pp. 1852-1857, 2011.
- [19] L. Bahl, J. Cocke, F. Jelinek, and J. Raviv, "Optimal Decoding of Linear Codes for minimizing symbol error rate", *IEEE Trans. on Inf. Theory*, vol. 20, n. 2, pp. 284-287, March 1974.
- [20] J. Garcia-Frias, and Y. Zhao, "Near Shannon/Slepian-Wolf performance for unknown correlated sources over AWGN channels," *IEEE Trans. Commun.*, vol. 53, n. 4, pp. 555-559, April 2005.
- [21] T. J. Richardson, M. A. Shorollahi, and R. Urbanke, "Design of capacity approaching irregular low-density parity-check codes", *IEEE Trans. on Inf. Theory*, vol. 47, no. 2, pp. 619-637, Feb. 2001.