

## Horizontal Localization of Sound Images and Sound Sources for Monaural Congenital Deafness

Kyoko Takahashi and Daisuke Morikawa

Graduate School of Advanced Science and Technology, Japan Advanced Institute of Science and Technology  
1-1 Asahidai, Nomi, Ishikawa 923-1292, Japan  
E-mail: {kyoko.takahashi, morikawa} @jaist.ac.jp

### Abstract

It is well known that the interaural time difference, interaural level difference and spectral cues are used to determine three-dimensional sound localization in binaural hearing. In the case of monaural hearing, the interaural time difference and interaural level difference are not used. Therefore, it is assumed that there is a different perception of sound localization between binaural and monaural hearing. In this study, we investigate the difference in the horizontal localization of sound images and sources in monaural hearing. An experiment involving horizontal sound localization was performed with one female participant suffering from congenital complete hearing loss in the left ear. The experimental system consisted of 12 loudspeakers placed horizontally on the circumference of a circle having a radius of 1 m at 30° intervals. Four experimental sessions were performed (including 60 white-noise stimuli per session). Excluding the instances with no localization (12%), all sound images were localized on the right side (0–180°). It appeared that sound images were localized on the side with the normal-hearing ear but not on the side with the deaf ear. Sound source localization was possible generally over 360° (with  $\pm 30^\circ$  allowance, 90.8%). As a result, we confirmed that the localization of sound images and sources was different in congenital monaural hearing.

### 1. Introduction

In the field of spatial hearing, a “sound image” is defined as an image perceived from sound signals and a “sound source” is defined as something that generates sound signals. However, in the case of sound localization in binaural hearing, sound images and sources are almost indistinguishable owing to localization in the same dimension. This is because the interaural time difference, interaural level difference and spectral cues are available to determine sound localization in binaural hearing. By contrast, in monaural hearing, it is assumed that the localization of sound images and sources produces different results because monaural-hearing listeners only use spectral cues.

Several studies on sound localization in monaural hearing have been conducted. However, in these studies, only a few studies have been able to clearly distinguish sound images from sound sources. It is predicted that this is the result of

the localization of sound images and sound sources.

In this study, we investigate the difference in the horizontal localization of sound images and sources in monaural hearing and perform two experiments on the localization of sound images and sound sources by a monaural congenital monaural deaf participant who is used to the perception of the sound direction in monaural hearing.

### 2. Experiment

#### 2.1 Experimental system and stimuli

Figure 1 shows the experimental setup. The system comprised a Windows-based PC, two digital-to-analog converters (DACs) (RME, Fireface USX), six power amplifiers (ONKYO, CR-M755) and 12 loudspeakers (Vifa, MG10 SD-09-08). The sampling rate of the DACs was 48 kHz and the quantization bit length was 24 bits. The loudspeakers were placed horizontally on the circumference of a circle having a radius of 1 m at 30° intervals in a soundproof room. The height of the loudspeakers was 1.1 m. The participant sat on a chair set at the center of the circle of loudspeakers such that the height of the opening of the external acoustic canal was the same as the height of the loudspeakers and the perceived stimuli.

White noise was used as stimuli. The stimulus duration and interval time were both 3 s. A 30 ms linear taper window was applied at the beginning and the end of stimulus application. The sound pressure of the stimuli was 70 dB at the head center position.

#### 2.2 Participant and experimental method

The participant was a female (23 years old) suffering from monaural congenital deafness, having normal hearing in the right side ear and deafness in the left ear.

The experiment on the horizontal localization of sound images was carried out over four sessions. One sequence in a session included five stimuli from each loudspeaker at random. The total number of stimuli was 60 in the four sessions. The participant was instructed to face the front and keep her head still while the stimuli were presented, and to answer after the presentation of the stimuli was complete. Next, an ex-

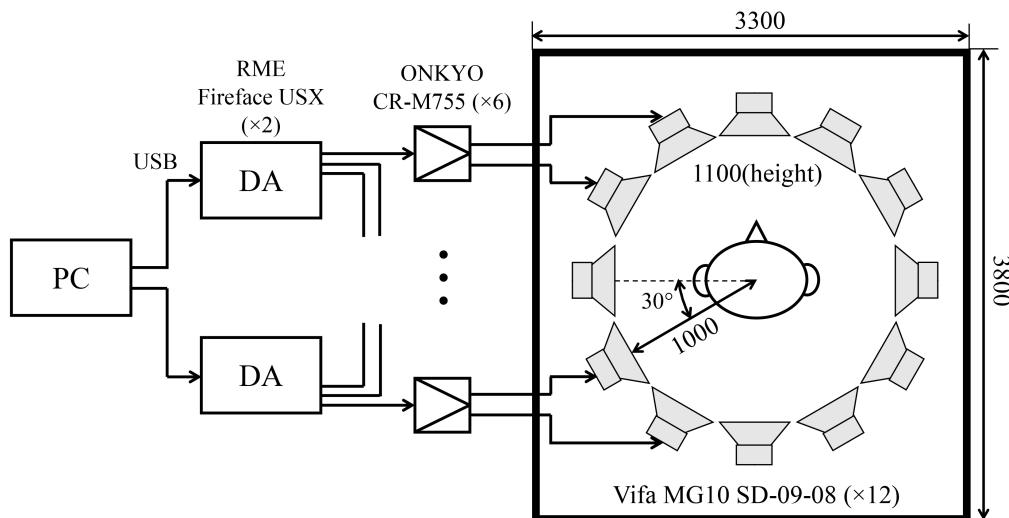

Figure 1: Experimental system

periment on the horizontal localization of sound sources was performed by following the same procedure.

The questionnaire forced a choice among one of 12 directions as the response, and the participant's responses gave the directions in which sound image and the sound source were localized.

### 3. Results

Figure 2 illustrates the introspective perception of the participant in the localization of a sound image and source. The two circles made of dashed lines represent the localized positions of the sound image and source. As shown in this figure, the participant perceived introspective differences between the localization of sound images and sound sources.

Figure 3(a) shows the result of the localization of sound images over four sessions, and Fig.3(b) shows the result of the localization of sound sources over four sessions. In each figure, the ordinate represents the perceived azimuth and the abscissa represents the azimuth of the loudspeaker presenting the stimuli. The front of the participant is  $0^\circ$  in the clockwise direction. The red points denote the answers related to external-head localization and the yellow ones indicate that the participant could not localize a given stimulus. The size of each point represents the number of responses. The upward right direction of the red diagonal line means that the perceived azimuth is in line with the azimuth of the loudspeakers. Front-back confusion did not appear in the results of the experiment on the localization of sound images and sources.

Figure 4 shows the number of responses in the horizontal localization of sound images and sources over four sessions for each sound image and source. The ordinate represents the

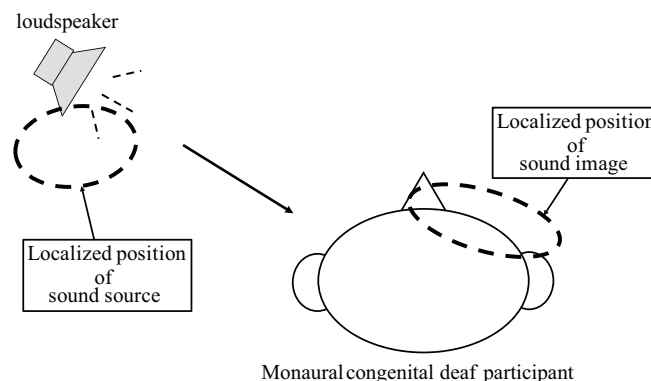

Figure 2: Perception of sound image and sound source for monaural congenital monaural deafness

number of responses where the sound image and source were localized, and the abscissa is the azimuth of the loudspeaker presenting the stimuli. The blue dashed line and the circular plots represent the results of the localization of sound images, and the red dashed line and circular plots represent the results of the localization of sound sources. As shown in Fig. 4, all sound images were localized over  $0-180^\circ$  (*i.e.*, on the normal-hearing side), except the unlocalized responses (12%), and sound images were not localized on the deaf side.

Figure 5 shows the concordance rate of the horizontal localization of sound images and sources with  $\pm 0$  and at  $\pm 30^\circ$  allowances. The group of bars on the left side represents the conductance rate of the localization of sound images, and the group on the right side represents that for the localiza-

tion of sound sources. In this figure, the yellow bars denote the rate of total responses, blue ones denote the responses from the deaf side and the red ones denote responses from the normal-hearing side. The concordance rate of the localization of sound images on the normal-hearing side was 95.7% with  $\pm 30^\circ$  allowance according to the left side of Fig.5. According to the right side of Fig.5, the concordance rate of the localization of sound sources was 90.8% with  $\pm 30^\circ$  allowance. On the normal-hearing side, the concordance rate was 99.3%. On the deaf side, it was 81.7%.

#### 4. Discussion

From the result of the experiment on the localization of sound images, the direction of localization of sound images was almost concordant with the direction of the stimuli on the normal-hearing side, and it was not concordant with the direction of stimuli on the deaf side: in some cases, there was no localization, and in other cases, there was a difference between the direction of localization of the sound image and the direction of the stimuli. In contrast, in the result of the experiment on the localization of a sound source, the direction of localization of the sound image was generally concordant with the direction of localization of the sound source over 360°. These results suggest that in monaural hearing, the horizontal localization of sound images is possibly different from that of sound sources.

The trend that sound images of stimuli presented on the deaf side were localized on the normal-hearing side agrees with the results of Wightman and Kistler [1] and Slattery and Middlebrooks [2]. However, the result that sound images were localized on the normal-hearing side when the stimuli were presented on the normal-hearing side is not in accord with these results, but it agrees with the result of Butler, who employed broadband noise [3]. The same trend can be seen in the result of the horizontal localization of sound images by Kojima and Hirahara [4]. The agreement of the present study with those of Butler, and Kojima and Hirahara in terms of monaural hearing seems to stem from the fact that the latter experiments employed participants with binaural hearing to test monaural hearing without providing them with localization training. The participants of these studies did not localize sound sources but did localize sound images. The duration of the stimuli in Wightman and Kistler, and Slattery and Middlebrooks was short (250 ms), and the experiments included advance localization training, which may have led to confusion between the localization of sound images and source, as well as front-back confusion.

Strelnikov *et al.* reported the effect of previous localization training on monaural hearing [5], and Slattery and Middlebrooks reported that a few congenitally monaural deaf people are able to localize sound generally over 360° [2]. These reports are in agreement with our result that the participant was able to localize the sound source over 360°. It is believed that this correspondence appears because congenitally monaural deaf people often learn sound localization naturally over the course of their life. However, the result of localization of the

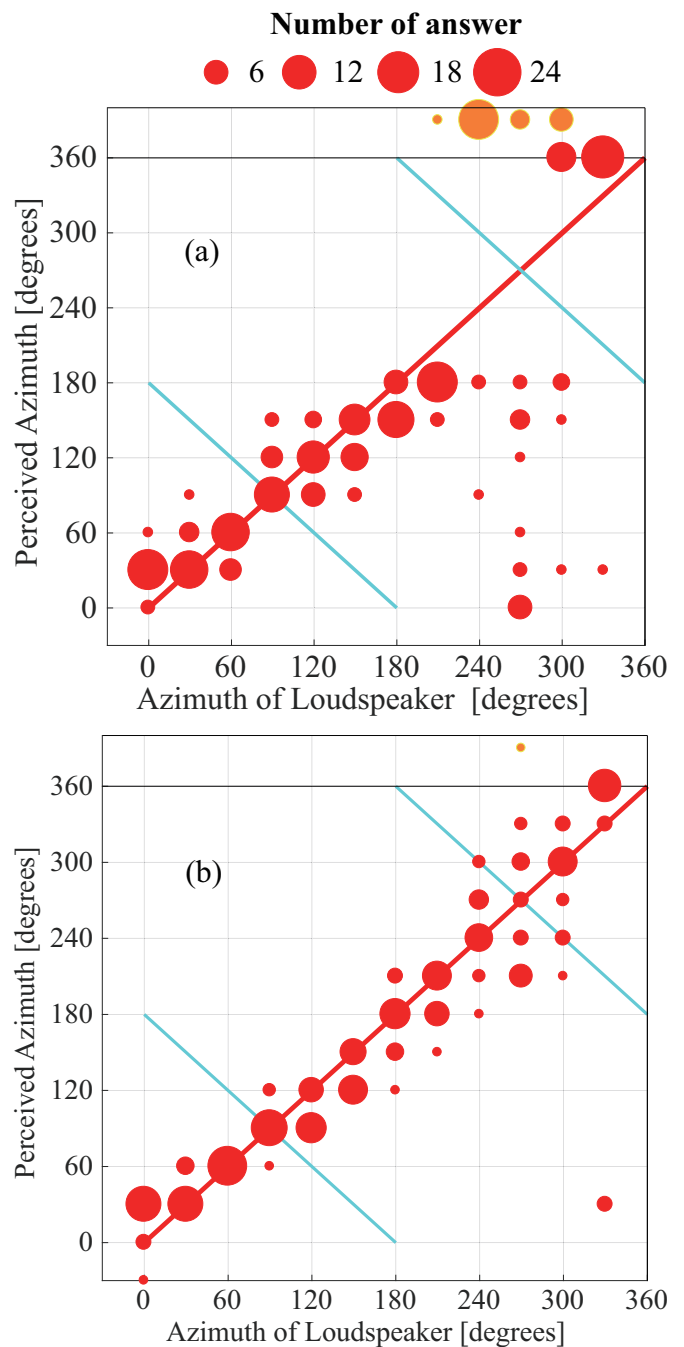

Figure 3: Result of horizontal localization of (a) sound images and (b) sound sources

sound images in this study does not agree with the results of the aforementioned previous reports.

Therefore, it is assumed that Butler, and Kojima and Hirahara presented the results of the localization of sound images, while Strelnikov *et al.* and Slattery and Middlebrooks presented the results of the localization of sound sources.

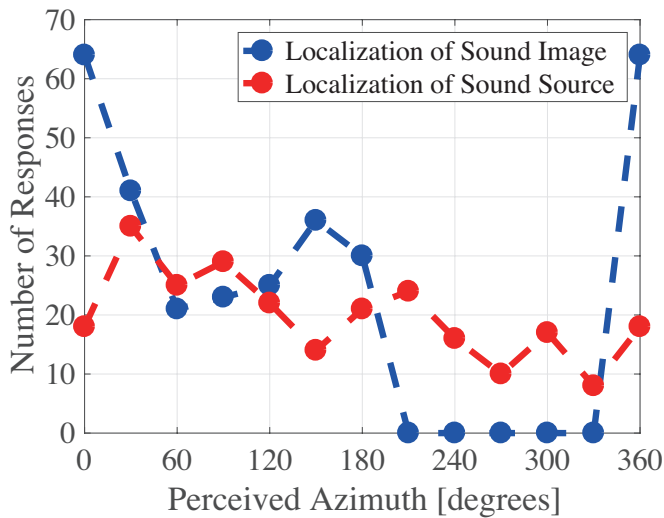

Figure 4: Number of responses in horizontal localization of sound images and sources

With these results, it appears that congenitally monaural deaf people may use different information in the localization of sound images and sources. In the localization of sound images, they use spectral cues, and in the localization of sound sources, they use spectral cues and the sound level. It may be possible to use the information that the localization of sound images and sources is based on different information for prediction of the localization of sound sources in monaural experiments.

## 5. Conclusion

Experiments on the horizontal localization of sound images and sources were carried out with a congenitally monaural deaf participant to investigate differences in the horizontal localization of sound images and sources in monaural hearing. It was found that the localization of sound images and sources was different in congenital monaural hearing. This suggests that it will be necessary to distinguish between sound images and sources when conducting sound localization experiments with monaural hearing objects.

## Acknowledgments

Part of this study was supported by the Cooperative Research Project Program of the Research Institute of Electrical Communication, Tohoku University (H27/A13), and the Telecommunications Advancement Foundation. We would like to thank Professor Tatsuya Hirahara of Toyama Prefectural University for his cooperation in carrying out these experiments.

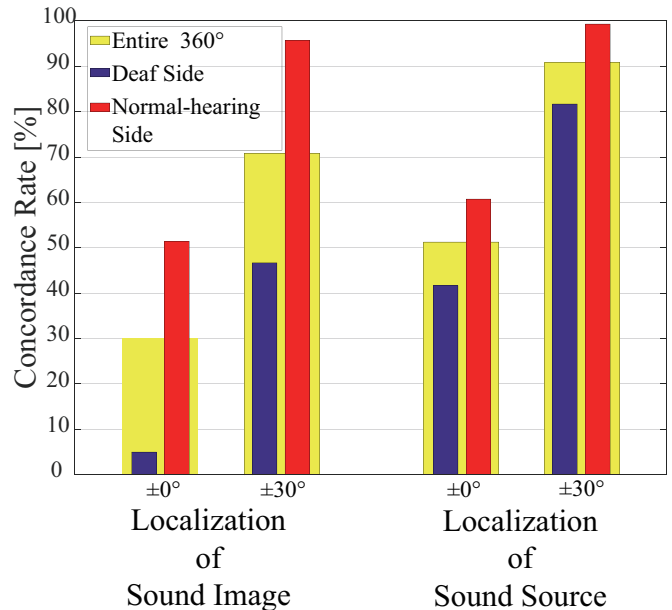

Figure 5: Concordance rate of horizontal localization of sound images and sources with  $\pm 0$  and  $\pm 30^\circ$  allowances

## References

- [1] F. L. Wightman and D. J. Kistler: Monaural sound localization revisited, *J. Acoust. Soc. Am.*, Vol. 101, No. 2, pp. 1050-1063, 1997.
- [2] W. H. Slattery III and J. C. Middlebrooks: Monaural sound localization: Acute versus chronic unilateral impairment, *Hear. Res.*, Vol. 75, No. 12, pp. 38-46, 1994.
- [3] R. A. Butler: The bandwidth effect on monaural and binaural localization, *Hear. Res.*, Vol. 21, No. 1, pp. 67-73, 1986.
- [4] D. Kojima and T. Hirahara: Monaural horizontal sound localization in head still and head movement conditions, *IEICE Technical Report, EA2014-44*, Vol. 114, No. 358, pp. 25-30, 2014 (in Japanese).
- [5] K. Strelnikov, M. Rosito and P. Barone: Effect of audio-visual training on monaural spatial hearing in horizontal plane, *PLoS ONE*, Vol. 6, No. 3, pp. 1-9, 2011.