

Game Theory Technique for Cooperative and Collaborative Resource Management in Small Cell Networks

Shashi SHAH

Japan Advanced Institute of Science and Technology

Doctoral Dissertation

**Game Theory Technique for Cooperative and Collaborative
Resource Management in Small Cell Networks**

Shashi SHAH

Supervisor(s): Yuto LIM
Somsak KITTIPIYAKUL

School of Information Science
Japan Advanced Institute of Science and Technology

December, 2018

Abstract

The exponential growth in capacity demand and ubiquitous coverage/connectivity requirement of wireless cellular networks has shifted mobile network operators' interest toward base station densification. Base station densification is essential to meet the capacity demand and coverage requirement by massive deployment of small cells by covering areas that are much smaller as compared to the coverage area of macrocell base stations. Small cells are attractive choice for operators due to its low cost and ease of deployment, and flexible coverage capability allowing them to reuse the available spectrum and thus increasing the area spectral efficiency. However, the advantages of small cells could come short whenever neighboring small cells compete to utilize common spectral resources that would result in severe interference. Also, centralized control for resource allocation can be infeasible due to potentially dense and random deployment of small cells either by operators or customers. Hence, radio resource management in small cell networks becomes essential to achieve the expected gains from small cells.

In this regard, I propose a cooperative and collaborative resource management (CCRM) framework that enables cooperative intra-connection among small cells of an operator and collaborative interconnection among multiple operators for proper utilization of network resources (both infrastructures and spectrum). The cooperative resource management performed at the network edge, i.e., among small cell access points, in-cooperates information exchange mechanism among small cells allowing them for distributed resource allocation to mobile stations. The collaboration formation among multiple operators offers users with multi-operator small cells support. This facilitates network users with an extension of network coverage and services availability regardless of their operator's network coverage, and evolves small cells to meet the expectation of a networked society.

To look for distributed resource (subchannel) allocation, first, I study the performance of best-response strategy as a game theoretic solution analyzed under the physical interference model. However, in "traditional" best-response strategy, players are assumed to be coordinated and restricted to take turns while updating their strategies. To overcome these requirements

of coordination among players and restricting at most only one player to update their strategy, I model strategy update criteria of players in a game such that multiple players can repeatedly and simultaneously take actions following best-response strategies. Through the proposed algorithms, stochastic best-response distributed subchannel selection (SBDSS) and cooperative best-response distributed subchannel selection (CBDSS), I study for cases and associated limitations when multiple players may update their subchannel allocation strategies that could inevitably speed-up the convergence process to steady-state. In SBDSS, no information exchanges and coordination among players are required and each player updates its strategy of subchannel selection following stochastic best-response. The randomness in strategy updates result in uncoordinated sequential updates and avoids the problem of *simultaneous moves* that would have resulted in oscillations between some set of strategy profiles. However, this results in a slow convergence to steady-state. To speed-up the convergence, in CBDSS, I assume coordination among neighboring small cells to act cooperatively while best-responding to their strategy. Here, I limit multiple players to update to the same strategy at a given time, such that the number of players who can simultaneously update their strategy is equal to the number of available strategies. This provides notable improvement in terms of rate of convergence to steady-state.

Although the problem of distributed resource allocation can be addressed through the proposed schemes following best-response dynamics, the existence of a steady-state solution, i.e., a pure strategy Nash equilibrium, cannot be guaranteed. To guarantee for the existence of a steady-state solution, I utilize the concept of marginal contribution and propose marginal contribution-based best-response (MCBR) algorithm to cope with dynamic and limited information in the small cell network. Here, the objective is to find a distributed subchannel allocation that maximizes the welfare of the small cell network, defined as the total system capacity. MCBR is theoretically proven to be an exact potential game, which is a class of potential game that guarantees convergence to a pure strategy steady-state, i.e., the Nash equilibrium. I also validate the convergence property and evaluate the performance through simulations for various performance metrics.

Finally, to offer multi-operator small cells support, I formalize a mechanism for multi-operator collaboration through negotiation to establish mutual agreement acceptable to each involved party. This provides operators with collaboration gains, and motivates them to uti-

lize their exclusively owned network resources to serve others' subscribers. Such collaboration would enable subscribers of one operator to utilize other operators' network resources and maintain ubiquitous connectivity. Collaboration, in turn, enables: to enhance service levels to users with improved network resources availability, to avoid situations of under-utilization of radio network resources, to improve revenue generated by serving an increased market share, and to create a bring-your-own-device environment by maintaining small cell network services to subscribers regardless of coverage availability from their operator.

Keywords: Small Cells; Distributed Subchannel Selection; Game Theory; Best-Response Strategy; Simultaneous Move; Cooperative Games; Non-Cooperative Games; Potential Games; Marginal Contribution; Collaboration; Negotiation.

Acknowledgments

First of all, I would like to express my sincere gratitude to my family members, especially to my parents for their continuous encouragement, love and support throughout my life. I would like to dedicate this dissertation to my Papa for always being there for me, providing me with proper advice and guidance. I always love and miss you Papa.

I would like to wish my sincere gratitude to my supervisors Associate Professor **Yuto LIM** and Assistant Professor **Somsak KITTIPIYAKUL** for their valuable advice, guidance, time and motivation throughout this dissertation. I truly appreciate their patience and encouragement in discussing research ideas. Their insightful comments during meetings have always been helpful in improving my work.

I am also thankful to the members of examination committee, Professor **Yasuo TAN**, Professor **Mineo KANEKO** and Associate Professor **Komwut WIPUSITWARAKUN**, for their valuable comments and suggestions to enhance the quality of this dissertation.

My sincere gratitude goes to the members of “Network Seminar” group meeting from Sirindhorn International Institute of Technology (SIIT), Thammasat University, for their valuable suggestions and guidance. Specially to the faculty members, Assistant Professor **Somsak KITTIPIYAKUL**, Associate Professor **Komwut WIPUSITWARAKUN**, Assistant Professor **Prapun SUKSOMPONG** and Associate Professor **Steven GORDON**. Also, I am thankful to Associate Professor **Attaphongse TAPARUGSSANAGORN** from Asian Institute of Technology (AIT) for his guidance.

I would like to express my sincere gratitude to Associate Professor **Poompat SAENGUDOMLERT** from Bangkok University’s Center of Research on Optoelectronics, Communications, and Control Systems (BU-CROCCS) for his supports and encouragement in pursuing my doctoral study.

Last but not least, I wish my sincere appreciation to all members of “LIM Lab” and “TAN Lab” from Japan Advanced Institute of Science and Technology (JAIST) for their immense support and cooperation.

Contents

Abstract	ii
Acknowledgments	v
List of Figures	ix
List of Tables	xi
List of Abbreviations	xii
List of Symbols	xvii
1 Introduction	1
1.1 The Journey Towards Future Cellular Networks	3
1.2 Research Trends for Future Cellular Networks	4
1.3 Resource Allocation in Cooperative and Collaborative Multi-Operator	10
1.4 Research Vision, Purpose and Objectives	12
1.5 Dissertation Outline	13
2 Background and System Model	15
2.1 Introduction	15
2.2 Small Cell Networks	17
2.2.1 Small Cells: Over the Years	18
2.2.2 Operators' and Subscribers' Perspective	20
2.2.3 Technical Challenges	21
2.3 System Model	25
2.3.1 System Model	25

2.3.2	Radio Resource Scenarios	26
2.4	Game Theoretic Framework	27
2.4.1	Non-Cooperative and Cooperative Games	28
2.4.2	Preliminary Definitions	28
2.4.3	Potential Games and its Characteristics	31
2.5	Summary	32
3	Cooperative and Collaborative Resource Management Framework	33
3.1	Introduction	33
3.2	Background	35
3.2.1	Long Term Evolution Architecture	35
3.2.2	Multi-Operator Networks	38
3.2.3	Multi-Operator based Network Sharing	40
3.3	Cooperative and Collaborative Resource Management Framework	41
3.3.1	Multi-Operator Small Cell Networks: General Network Architecture	42
3.3.2	Small Cell Networks: Functional Architecture	44
3.3.3	Cooperative and Collaborative Resource Management: System Architecture	46
3.4	Summary	50
4	Cooperative Resource Allocation Management and Control	51
4.1	Introduction	51
4.2	State-of-the-Art for Resource Allocation Management	52
4.3	Best-Response Strategy for Distributed Subchannel Allocation	55
4.3.1	Non-Cooperative Best-Response for Distributed Subchannel Allocation	56
4.3.2	Cooperative Best-Response for Distributed Subchannel Allocation	64
4.3.3	Computational Complexity Analysis	66
4.4	Marginal Contribution-Based Distributed Subchannel Allocation	66
4.4.1	Marginal Contribution	67
4.4.2	Utility Function Design with Limited Information Feedback	68
4.4.3	Information Feedback from Neighboring Small Cells	69
4.4.4	Distributed Algorithm for Subchannel Allocation	70

4.4.5	Computational Complexity Analysis	72
4.5	Simulation Results	74
4.5.1	Performance in Sparse Scenario	75
4.5.2	Performance in Different Radio Resource Scenarios	79
4.6	Summary	83
5	Collaborative Multi-Operator Management and Control	85
5.1	Introduction	85
5.2	State-of-the-Art for Multi-Operator Network Sharing	86
5.3	Collaboration Management Module	89
5.3.1	MNO's Policy Profile	91
5.3.2	Negotiation for Collaboration	93
5.4	Overall Operation in CCRM Framework	96
5.5	Simulation Results	96
5.5.1	Effects of Strategy in Proposal Offers	98
5.5.2	Effects in Revenues	100
5.5.3	Effects in Average per User Data Rate	101
5.5.4	Effects in System Capacity	101
5.6	Summary	107
6	Conclusion	109
6.1	Conclusion and Discussion	109
6.2	Directions for Future Works	112
6.2.1	Presence of Cooperative and Non-cooperative Small Cells in the Network	112
6.2.2	Subscribers Initiated Service Demands	112
6.2.3	Multiple Negotiation Trades	113
	Bibliography	114
	Publications	125

This dissertation was prepared according to the curriculum for the Collaborative Education Program organized by Japan Advanced Institute of Science and Technology and Sirindhorn International Institute of Technology.

List of Figures

1.1	Wireless technology evolution.	2
2.1	Access policy for UEs in SCN [50].	23
2.2	System model.	25
2.3	Radio resource scenarios: (a) sparse, (b) moderate, and (c) dense.	27
2.4	<i>Prisoners' dilemma game</i>	29
3.1	Data consumption estimation, Cisco VNI (2015 – 2020).	34
3.2	The architectural difference between (a) UTRAN and (b) E-UTRAN.	36
3.3	EPS elements and interfaces.	37
3.4	SCN architecture [73].	38
3.5	Multi-operator networks: (a) <i>standalone</i> , (b) <i>mobile virtual network operators</i> , and (c) <i>third-party operator</i>	39
3.6	Approaches for multi-operator network sharing: (a) MORAN, (b) MOCN, and (c) GWCN.	41
3.7	A general network architecture of multi-operator small cell networks.	42
3.8	A functional architecture of small cell networks.	45
3.9	A system architecture of CCRM.	47
4.1	The example of three homogeneous links and two subchannels: (a) the instan- taneous total capacities, C_0 and C_1 , and the average total capacity for the mixed NE strategies C_{MNE} for varying SNR, (b) the Price of anarchy.	60
4.2	Illustration of a part of the Markov chain.	64
4.3	Average total capacity as a function of switching probability.	65
4.4	Average system capacity with varying numbers of subchannels.	76
4.5	The evolution of number of links on each of the subchannels.	77

4.6	System capacity comparison.	78
4.7	Average system capacity over 200 random deployments.	79
4.8	Average system capacity versus Fairness.	81
4.9	Average system capacity in different radio resource scenarios.	82
4.10	Average interference in different radio resource scenarios.	83
5.1	Cooperative and collaborative multi-operator operation in CCRM framework.	97
5.2	Proposal offers of a feeder and a seeker MNO depending upon values of ζ_f and ζ_s i.e., $0 < \zeta < 1$ and $\zeta > 1$, and $M_f = 10$ and $M_s = 100$. A case of agreement in a negotiation trade, where agreement price follows $\phi'_f \leq \phi_a \leq \phi'_s$	98
5.3	Proposal offers of a feeder and a seeker MNO depending upon values of ζ_f and ζ_s i.e., $0 < \zeta < 1$ and $\zeta > 1$, and $M_f = 50$ and $M_s = 100$. A case of no agreement in a negotiation trade.	99
5.4	Revenues of the feeder and the seeker MNOs depending upon values of ζ_f and ζ_s i.e., $0 < \zeta < 1$ and $\zeta > 1$, and $M_f = 10$ and $M_s = 100$	100
5.5	Before and after collaboration average per user data rate of the feeder and the seeker MNOs.	101
5.6	Before and after collaboration comparison of system capacity of the seeker MNO.	102
5.7	Before and after collaboration comparison of system capacity of the feeder MNO.	103
5.8	Before and after collaboration comparison of average system capacities of the seeker MNO with different resource allocation schemes. (a) for $M_f = 10$, $M_s = 100$ and (b) for $M_f = 30$, $M_s = 100$	105
5.9	Comparison of average system capacities of the seeker MNO while standalone, shared, and in collaboration with the feeder MNO.	106
5.10	Comparison of initial revenues with revenues obtained from sharing network resources of the feeder and the seeker MNOs.	107

List of Tables

1.1	Key characteristics from 1G to 5G. [3, 9]	5
2.1	General cellular network specifications.	16
2.2	Femtocell and small cell specifications.	17
2.3	Benefits of small cells from the perspective of operators and subscribers.	21
4.1	Simulation parameters	74
4.2	Fairness indices comparison.	80
4.3	Information feedback requirements from average number of links.	84

List of Abbreviations

1G	First Generation
2G	Second Generation
3G	Third Generation
3GPP	3 rd Generation Partnership Project
4G	Fourth Generation
5G	Fifth Generation
5G-PPP	5G Infrastructure Public Private Partnership
ABS	Almost Blank Subframe
AC	Admission Control
AMPS	Advanced Mobile Phone System
AWGN	Additive White Gaussian Noise
BBU	Baseband Unit
BR	Best-Response
BS	Base Station
BYOD	Bring-Your-Own-Device
CA	Carrier Aggregation
CAPEX	Capital Expenditure
CBSS	Cooperative Best-Response Distributed Subchannel Selection
CC	Control and Coordination
CCRM	Cooperative and Collaborative Resource Management
CDMA	Code Division Multiple Access
CESC	Cloud-Enabled Small Cell
CMM	Collaboration Management Module
CN	Core Network

CoMP	Coordinated Multi-Point
CPRI	Common Public Radio Interface
CQI	Channel Quality Index
CRAM	Cooperative Resource Allocation Management
C-RAN	Cloud-Radio Access Network
CRE	Cell Range Expansion
CSG	Closed Subscriber Group
DBS	Distributed Base Station
DSL	Digital Subscriber Line
eICIC	Enhanced Inter-Cell Interference Coordination
EPC	Evolved Packet Core
EPG	Exact Potential Game
EPS	Evolved Packet System
E-UTRAN	Evolved UMTS Terrestrial Radio Access Network
FD	Full-Duplex
FDM	Frequency Division Multiplexing
FDMA	Frequency Division Multiple Access
feICIC	Further Enhanced Inter-Cell Interference Coordination
FFR	Fractional Frequency Reuse
GPRS	General Packet Radio Service
GPS	Global Positioning System
GSM	Global System for Mobile
GT	Game Theory
GWCN	Gateway Core Network
HBS	Home Base Station
HDTV	High-Definition Television
HSS	Home Subscriber Server
ICIC	Inter-Cell Interference Coordination
InP	Infrastructure Provider

IP	Internet Protocol
IoT	Internet of Thing
LTE	Long Term Evolution
MBS	Macrocell Base Station
MC	Marginal Contribution
MCBR	Marginal-Contribution-based Best-Response
MIMO	Multiple-Input Multiple-Output
MME	Mobility Management Entity
mm-wave	Millimeter-Wave
MNO	Mobile Network Operator
MOCN	Multiple Operator Core Network
MORAN	Multiple Operator Radio Access Network
MS	Mobile Station
MVNO	Mobile Virtual Network Operator
NAS	Non Assess Stratum
NB-IoT	Narrowband Internet of Thing
NE	Nash Equilibrium
NMT	Nordic Mobile Telephone
NRT	Neighbor Relation Table
OAM	Operation Administration and Management
OFDM	Orthogonal Frequency Division Multiplexing
OFDMA	Orthogonal Frequency Division Multiple Access
OPEX	Operational Expenditure
OSA	Opportunistic Spectrum Access
OSG	Open Subscriber Group
PCI	Physical Cell Identity
PDN	Packet Data Network
PG	Potential Game
P-GW	Packet Gateway

PMOC	Policy-based Multi-operator Collaboration
PoA	Point of Anarchy
POTS	Plane Old Telephone System
QoE	Quality of Experience
QoS	Quality of Service
RAN	Radio Access Network
RAT	Radio Access Technology
RF	Radio Frequency
ROI	Return On Investment
RRH	Remote Radio Head
RRM	Radio Resource Management
RSRP	Reference Signal Receive Power
RSS	Received Signal Strength
SAE	System Architecture Evolution
SAP	Small Cell Access Point
SBDSS	Stochastic Best-Response Distributed Subchannel Selection
SBS	Small Cell Base Station
SCGW	Small Cell Gateway
SCN	Small Cell Network
SESAME	Small Cells Coordination for Multi-Tenancy and Edge Services
S-GW	Serving Gateway
SINR	Signal-to-Interference-plus-Noise Ratio
SLA	Service Level Agreement
SMS	Short Message Service
SNR	Signal-to-Noise Ratio
SP	Small Cell Point
SPP	Small Cell Portal Point
TDMA	Time Division Multiple Access
TPC	Transmit Power Control

UE	User Equipment
UMTS	Universal Mobile Telecommunications Service
UTRAN	UMTS Terrestrial Radio Access Network
VNI	Visual Networking Index
WCDMA	Wideband Code Division Multiple Access

List of Symbols

$\mathcal{N}, \mathcal{M}, \mathcal{K}$	Set of small cell base stations, mobile stations, and subchannels with cardinality N , M , and K
M_i	Number of mobile stations associated associated to i
B	Channel bandwidth
$h_{ii,k}$	Channel gain for transmission on link i on subchannel k
$h_{i'i,k}$	Channel gain for interference from the transmitting small cell base station for link i' to the receiving mobile station of link i on subchannel k
P_{max}	Maximum transmit power of small cell base station
$P_{i,k}$	Transmit power for link i on subchannel k
$\gamma_{i,k}$	Signal-to-interference-plus-noise ratio for link i on subchannel k
$I_{i,k}$	Co-channel interference of link i on subchannel k
σ^2	Additive white Gaussian noise power
\mathcal{C}	Total capacity
$\mathcal{C}_{i,k}$	Capacity for link i on subchannel k
\mathcal{G}	Strategic form game
\mathcal{I}	Set of players
\mathcal{S}_i	Set of strategy for each player $i \in \mathcal{I}$
s_i	Strategy of player i , $s_i \in \mathcal{S}_i$
\mathbf{s}_{-i}	Strategy of all players except i , $\mathbf{s}_{-i} \in \mathcal{S}_{-i}$
u_i	Utility/payoff received by player $i \in \mathcal{I}$
$br_i(\mathbf{s}_{-i})$	Best-response strategy of player i to the profile of strategies \mathbf{s}_{-i} played by all opponents $-i$

\tilde{P}	Potential function
$W_k(\mathbf{s})$	Total welfare (in term of capacity) from all links who are using subchannel k
t	Time-slot
\mathbf{p}_i	Subchannel selection probability vector of link i
$p_{i,k}(t)$	Probability of choosing subchannel k for sensing at time-slot t by link i
\tilde{r}_i	Normalized utility increment of link i
β	Learning step-size
R	Radius (in meters) of a circular coverage area where small cells are uniformly distributed in cluster
r	Radius (in meters) of a circular coverage area of small cells within which mobile stations are uniformly distributed
D	Transmitter-receiver link distance (in kilometers)
$\rho_i^{M_i}$	Average per user data rate offered by MNO i for serving M_i users
m_i	Additional users from MNO i
ϕ_i	Price per user per unit (bps) of data rate service
\mathbf{R}_i	Total revenue of MNO i
C	Counter in a negotiation trade
c	Negotiation trade round
\mathcal{D}_c	A set of collection of negotiation trades at round c
$ d_c $	Total number of negotiation trade at round c
α	A time-dependent function
ζ	Concession pace
ϕ_{sf}^c	Price proposal offer of seeker to feeder at round c
ϕ_{fs}^c	Price proposal offer of feeder to seeker at round c
ϕ'_s	Reservation price of seeker
ϕ'_f	Reservation price of feeder

Chapter 1

Introduction

The wireless cellular networks have witnessed an exponential growth in mobile data traffic, mainly due to popularity of multimedia services and high data rate applications. Cisco's visual networking index (VNI) analysis for global mobile data traffic forecast [1] predicts that by 2020: the number of mobile connected devices per capita to reach 1.5, and global mobile data traffic to grow nearly by 8-folds to 30.6 exabytes (1 exa = 10^{18}) per month. Today, the users of wireless cellular networks demands for more reliable services with high data rates, and thus mobile network operators (MNOs) are compelled to upgrade their network for improved system capacity and meet the increasing traffic demands.

The wireless cellular networks are changing its conventional topology and architecture from voice-centric to data-centric, circuit switched to packet switched, and centrally optimized for coverage towards capacity based deployment [2]. The wireless communications have evolved accordingly, from the second generation (2G) systems of early 1990s where first digital cellular technology was introduced, along with deployment of third generation (3G) systems with high speed data networks followed by the fourth generation (4G) systems with mobile broadband services. Next is the much anticipated fifth generation (5G), which is envisioned to provide higher data rates, enhanced quality of experience (QoE) to users, reduced latency, improved energy efficiency, etc [3]. The wireless technology evolution is shown in Fig 1.1 [4]. The figure shows that fewer standards are being proposed for 4G than in previous generations where only two candidates have being actively developed today: 3GPP LTE-Advanced and IEEE 802.16m.

The "Cooper's law of spectral efficiency" by Martin Cooper, the inventor of first hand-held cellular mobile phone states that, "*The wireless capacity has doubled every two-and-a-half*

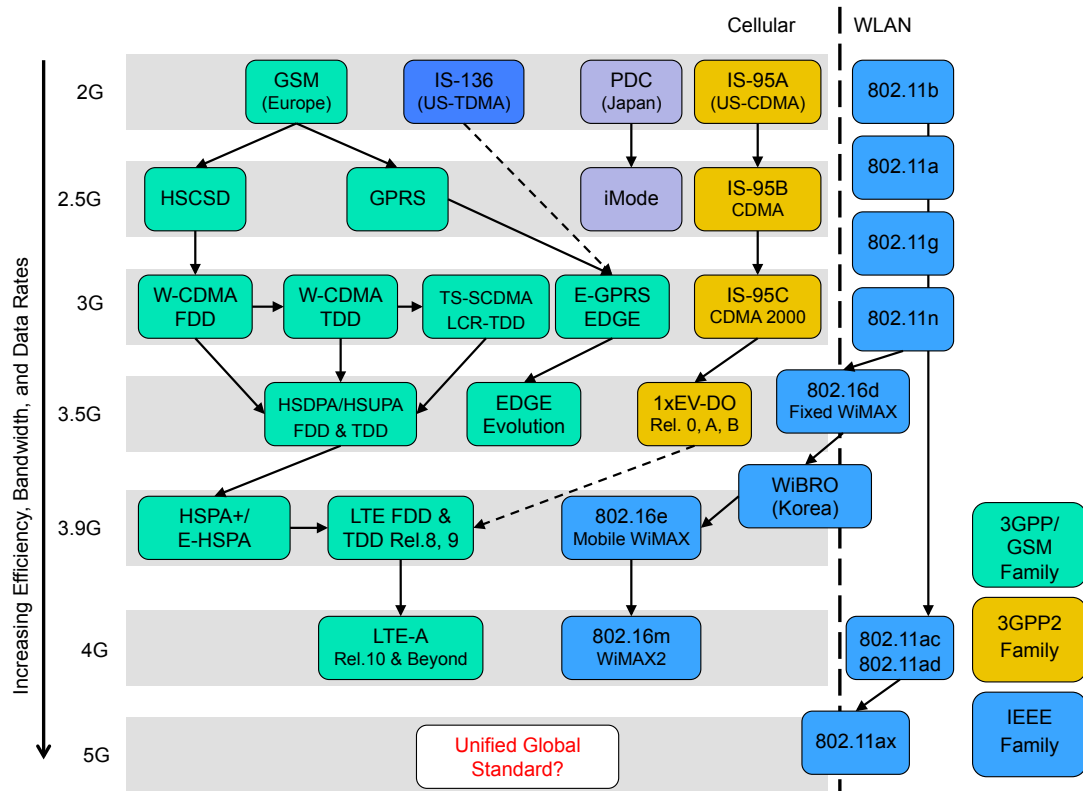

Figure 1.1: Wireless technology evolution.

years over the last 104 years”. This observation simply states that the maximum number of voice/data transactions over the radio spectrum doubles every 30 months [5]. This translates to an approximately million-fold system capacity growth since 1957, the invention of radio, and it can be attributed to three main factors: densification of base stations, wider radio spectrum, and improvement in link efficiency. Moreover, densification of base stations (BSs), which results in smaller cell size with reduced transmitter-receiver distance, contributes to an enormous gain that is mostly obtained by efficient spatial reuse of spectrum, i.e., improved area spectral efficiency [5].

A primary technology for the densification of existing cellular networks is through massive deployment of small cells [6, 7]. Small cells are generally short-ranged, low cost, and low power BSs that are deployed to enhance radio coverage and capacity by covering areas that are much smaller as compared to the coverage area of macrocell BSs (MBSs) [6]. Enhanced radio coverage is to bring a new service (or level of service) to an area that had not experienced it before, where as enhanced capacity provides a given level of service experience to increased number of users in a given area. Due to the low cost and ease of deployment, small cells

have been an attractive choice to MNOs to improve their cellular coverage, both outdoor as well as indoor, such as: homes, offices, public hot-spots, etc. By reducing the cell size with flexible coverage capability, MNOs can have much higher deployment density of small cells and increase the area spectral efficiency through higher spectrum reuse [7]. However, the radio resource management becomes critical issue in small cell networks (SCNs) whenever coexisting small cell BSs (SBSs) compete for the reuse of same available spectral resources and may experience severe interference, thus limiting their expected gains.

1.1 The Journey Towards Future Cellular Networks

The first generation (1G) of wireless telephone technology, introduced in 1980s, was analog systems such as advanced mobile phone system (AMPS) and nordic mobile telephone (NMT). They used frequency division multiplexing (FDM) to divide the spectrum bandwidth into specific frequencies to be assigned to individual calls.

The 2G wireless telephone technologies were characterized by digitization and compression of speech as compared to 1G, which provided only voice services based on analog radio transmission techniques. It introduced short message service (SMS) followed by higher data rate transmission for web browsing in subsequent technologies such as in general packet radio service (GPRS).

The 3G offered much higher data rates as compared to its predecessors (peak data rate of 2 Mbps for indoor low mobility applications and 144 kbps vehicular) and enabled new services such as global positioning system (GPS), mobile TV, video conferencing, etc [4]. It uses combination of circuit switching and packet switching for voice and data respectively. Moreover, subsequent enhancements of 3G technologies supports packets data rate upto 14.4 Mbps, multi-media communication devices (e.g., mobile TV), video conferencing and several location based services such as weather or traffic updates.

Finally, the 4G technology is characterized to provide enhanced peak data rates (1 Gbps for low mobility and 100 Mbps for high mobility), low latency (transition from idle to connected, < 100 ms, and dormant user to get synchronized, < 10 ms), improved spectral efficiency (15 bps/Hz in downlink for antenna configuration 4×4 , and 6.75 bps/Hz in uplink for antenna configuration 2×4) and high mobility (upto 350 Km/h) to support advanced mobile services and applications [4, 8]. The infrastructure of 4G is only packet-based (all-IP). It supports a

wide variety of dedicated applications such as Internet protocol (IP) telephony, ultra-broadband Internet access, high-definition television (HDTV), online gaming, content sharing, and social networking, and introduces the concept of connectivity anytime and anywhere.

The 4G technology is evolving towards next generation, i.e., the 5G. Some of the key directions for such evolution are:

- dense deployment of small cells to enhance coverage and system capacity with introduction of features such as coordinated multi-point transmission and reception (CoMP) and further enhanced inter-cell interference coordination (eICIC) that offer improvements in cell edge performance
- increment of bandwidths in combination with carrier aggregation (CA), and
- introduction of low complexity type user equipment (UE) to accommodate large numbers of UEs, such as through narrowband IoT (NB-IoT).

Table 1.1 briefly summarizes some of the key characteristics of wireless technologies from 1G to 5G.

1.2 Research Trends for Future Cellular Networks

The expectations from future cellular networks grow rapidly as wireless communications become an integral part of our day-to-day activity. Some of the notable expectation from future wireless networks are as follows [3, 6, 9]:

- Capacity and throughput improvement: $1000\times$ of throughput improvement over 4G
- Network densification: $1000\times$ higher mobile data per unit area, and $10000\times$ higher number of connecting devices
- High data rate: 10 Gbps cell data rate
- Reduced latency: 1ms end-to-end latency, and
- Energy efficiency: $10\times$ prolonged battery life

Table 1.1: Key characteristics from 1G to 5G. [3, 9]

Generations	Key Characteristics
1G	Analog systems, voice only services
2G	Digital systems, voice services accompanied by SMS, wide deployment around the world, simple multimedia services (MMS, web browsing, etc.)
3G	Enhanced multimedia and video stream services (video conference, mobile TV, 3D gaming, etc.), high speed web
4G	Flat IP-based architecture, data service of very high throughput, mobile broadband everywhere (mobile multimedia, anytime anywhere connectivity, global mobility support, integrated wireless solution, and customized personal services)
5G	High data rate services, ubiquitous connectivity, extreme device connection density, network densification, green communications, extremely low end-to-end service latency, advanced services and applications (e-health, M2M, smart city, service-oriented communication, etc.), Internet of things (IoT)

Some of the enabling technologies to address those expectations include [3, 6, 9, 10]: network densification (spatial and spectral), cloud-based radio access network (C-RAN), wireless resource virtualization, full-duplex communication, massive multiple-input multiple-output (massive-MIMO) and millimeter-wave (mm-wave) communications technologies. Approaches to address the requirements of future cellular networks are described below.

Densification of Cellular Networks

MNOs are trying to satisfy the growing traffic demand [1] by deploying cells of various sizes, i.e. densification of the existing cellular networks with massive deployment of small cells, instead of utilizing only typical MBSs. As more and more devices will be sharing the spectrum, dynamic radio resource management becomes critical in such dense environment to achieve the expected enhanced capacity by densification of cellular networks [11].

Channel Access Schemes

The advancement of radio access technologies (RATs) have led to improving service provision, by spectrum management (reuse and access control), which has primarily been the outcome of enhancement of spectrum access schemes from the frequency/time division multiple access (FDMA/TDMA) and wideband code division multiple access (WCDMA) to the orthogonal frequency division multiple access (OFDMA) schemes [12]. In OFDMA, the available bandwidth is divided into orthogonal subcarriers grouped as subchannels. OFDMA acts as multiple-access by assigning users with different group of subchannels. Moreover, OFDMA exploits channel variations in both frequency and time domains for the avoidance of interference, while code division multiple access (CDMA) can only exploit the time domain [12].

Simultaneous Transmission and Reception

Full-duplex (FD) communication enables a wireless device to transmit and receive data simultaneously in the same frequency band at the same time. It has potential to promisingly increase the spectral efficiency in point-to-point communication scenarios by factor of two and also improve latency [13]. Considering the short-range and low transmit power of SCNs, FD technology are practically beneficial in improving the spectral efficiency. However, interference management in FD communication becomes significantly complex due to new interference situations, such as *self-interference* generated due to internal interference between the transmitter and receiver circuits [14].

Wireless Technologies

Massive-MIMO technologies provide higher spectral efficiency via multiplexing gains. MIMO systems consists of large number of antennas at both the transmitter and receiver, and a greater degree of freedom in wireless channels can be offered to accommodate for more data [15]. The basic idea of massive-MIMO is that multi-user interference can be reduced as the number of antennas at transceivers becomes large [16]. Thus, a large number of spatial-division multiple-access users can be supported, and high data rate can be achieved.

mm-wave communication, in 30 and 200 GHz, provides with much more wider bandwidths to accommodate the rapidly increasing traffic demands. Due to the limited range of mm-wave signals, it will be suitable for SCNs, and along with high directional antennas it can provide im-

proved range and spatial separation. Combining mm-wave with spatial multiplexing gains from massive-MIMO offer the possibility of spectral efficiency gain compared to the commercial networks [14, 17].

Network Coding

The process of collision of signals can be considered as the process of network coding instead of interference. This would save retransmission and increase the throughput and spectral efficiency [18]. The BSs in a network perform one of more of the following roles: source of information into the network, destination, and relays to help move information between source-destination pairs. In network coding [19], relays send out functions of the packets they observe instead of simply routing them.

Transmit Power Control and Interference Management Control

Transmit power control (TPC) approaches for interference avoidance focuses on regulating transmit power of SBSs. Specially for dense deployed SBSs, users can avoid interference if the transmit power of each SBS is optimized. Both co-tier and cross-tier interference can be reduced by controlling transmission power of SBSs and also provide with an opportunity to utilize the entire spectrum with interference coordination [20]. In [21], initial power setting for SBSs based on clustering is done opportunistically with the knowledge of number of active SBSs in a cluster. Both centralized (macrocell sensing the cluster) and distributed (each small cell senses for the same cluster) sensing approach can be applied to estimate the number of active small cells per cluster, and then adjust initial power setting accordingly.

SCN includes operator deployed and owner deployed SBSs, where later has minimum intervention from the MNO. As a result, the SCN is characterized by randomly deployed uncoordinated SBSs. Co-channel deployment of SBSs achieves improved capacity but creates interference issues whenever transmission among neighboring occurs on the same channel. Interference management is considered as one of the most technical challenges in SCNs, due to dynamics of interference arising from several factors such as [22]: dynamic irregular coverage and load imbalance from varying transmit powers, multiple access policies, and prioritized resource allocation strategies.

Resource Allocation Management

One of key for area spectral efficiency is resource allocation management. Given issues such as limited spectrum availability and low spectrum utilization, an efficient allocation of radio resources is crucial in achieving high spectral efficiency. An improved resource utilization can be obtained through flexible spectrum management [23], where MNOs have freedom to flexibly allocate spectrum to the RATs they operate and to operate a RAT at various spectrum bands. Access policies such as opportunistic spectrum access (OSA) [24] allows users to identify unused spectrum bands at a given time and place, and use them while maintaining interference generated towards other users. Fractional frequency reuse (FFR) is one of basic mechanism proposed as an inter-cell interference coordination (ICIC) technique in OFDMA based wireless networks [25] that divides the entire frequency spectrum into several sub-bands, which can be assigned either to the inner or the outer region of the cell. It provides opportunity for interference management and enhance area spectral efficiency, where cell-edge users of adjacent cells do not interfere with each other and interference received by (and created by) cell interior users is reduced. However, it should be dynamic to consider varying spectrum utilization demands in the network.

Cooperative Networks

Cooperative relay transmission is one of the most effective approaches to improve the capacity and coverage of wireless networks. Network densification [11] with large number of BSs can incooperate multi-hop transmission [26], where signals can be forwarded from source to relatively distant destination. Cooperative relaying is a promising technique to enhance spectral efficiency that can use neighboring BSs to forward data toward the destination in order to achieve spatial diversity gain. The spectral efficiency is generally improved by introducing cooperative relaying into communication between an isolated source-destination pair. However, in an interference-limited environment, such as in dense SCNs, cooperative relaying cannot always improve the performance because of increased interference signal due to simultaneous transmission of multiple BSs [27]. The benefits of SCNs come at the price of more complicated network architecture due to several features such as dense and random deployment of BSs, intensity of interference, irregular coverage areas, limited transmit power, etc. The effect of dynamic footprint of small cells due to lower transmit power, and intensity of small cells

per unit area need to be considered for efficient spectral efficiency in cooperative networks with small cells.

Multi-Operator Management

Multi-operator infrastructure and spectrum sharing provides virtualization of the shared physical network resources and enables efficient utilization of the available network resources [28]. Infrastructure sharing improves the coverage availability to users in an under-served areas [28] while spectrum sharing provides opportunity to utilize under-utilized spectrum at various times [29] in a multi-operator scenario in SCNs. However, proper negotiation and agreement are needed to be reached before any collaboration between self-interested MNOs could take place, as high spectrum prices make MNOs reluctant to share their resources with competitors.

Collaborative Networks

The spectrum and network infrastructure are deployed and owned by a single MNO in a given location. In SCNs, multiple MNOs can co-exist operating on their dedicated spectrum to serve their users. The service availability and performance of small cells can be affected due to some faulty small cells. Moreover in some situations, services to an user might be barred due to resource outage in high traffic demand situations. On the other hand, during low traffic periods, all the SBSs belonging to several MNOs are unnecessarily required to be switched-on while serving relatively low users. One of the solution to avoid such undesirable situations is to switch small cell users to macro cell. However, the quality of service (QoS) from macrocell could not be guaranteed, given situations such as the small cell users are located at cell edge of macrocell coverage or congestion arising as to accommodate more number of users. One simple solution to overcome such situation is to allow some nearby small cells to serve the users of the faulty small cells [30]. Collaboration among MNOs with joint resource allocation and network planning during low traffic periods would allow MNOs to switch-off some SBSs and serve the users by a smaller number of active SBSs [31].

Cloud-Radio Access Network

The C-RAN concept is evolved from the distributed base station (DBS) architecture where the baseband processing units (BBUs) responsible for baseband processing is moved to the cloud

for centralized signal processing and management [32, 33]. The BBU pool in the cloud serves a particular area that consists of remote radio heads (RRHs) of macro and small cells. In contrast to the traditional 4G (e.g., LTE-A) architecture, where radio and baseband processing functionality is integrated inside the BS and inter-BS coordination is performed over X2 interface, the baseband processing is performed in the cloud (e.g., BBU pool). The cloud is connected to the mobile core network and BSs with the backhaul link and fronthaul link respectively. C-RAN also significantly reduces the capital expenditure (CAPEX) and operational expenditure (OPEX) [3]. For example, C-RAN lowers the cost of baseband processing and reduces the power consumption by performing load balancing and cooperative processing of signals from several BSs. C-RAN based network architecture can facilitate resources sharing, i.e., spectrum and infrastructure, among multiple operators. In such an architecture, a locally centralized collaborative resource allocation management among multiple operators can be employed to adapt to dynamic resource demands across all connected RRHs of macro and small cells.

1.3 Resource Allocation in Cooperative and Collaborative Multi-Operator

The necessity to fulfill the demand of high network traffic and data rates bring forth for BSs densification [11]. Small cells, which are typically characterized as short-range coverage, and low-powered radio access nodes, overlaid on macrocells, provide a more flexible and scalable deployment by reusing the available radio resources. BS densification with deployment of small cells help to decrease load of MBS, provide better link from reduced distance between serving BS and mobile stations (MSs), and enhance network performance with improved capacity and spectral efficiency [34].

Small cells can be deployed, by MNOs and users, within or to extend the range of a macrocell coverage in a distributed and random fashion. Moreover, users can deploy it in homes/offices and can even move it from one location to another. This in turns create a challenging problem for MNOs as it would require to manage radio resources dynamically [35]. The advantages of small cells could come short in a dense network due to strong interference from neighborhood small cells while utilizing the common radio resources [22]. It requires the necessity to be aware of its surrounding and should have distributed resource allocation technique

to cope any interference. Interference in an OFDMA based networks can occur among network users operating on the same subchannel [12]. Co-channel interference possess an increasingly severe threat as deployment of small cells becomes dense in urban environment that consists of large population of network users. Proper resource allocation to mitigate interference becomes an important issue and a challenge as it limits both capacity and cellular coverage. Moreover, random deployment of small cells by end-users particularly with co-channel spectrum allocation give rise to additional interference issues. The interference environment in SCNs become quite different than in conventional cellular networks because of aforementioned issues.

Moreover, utilizing centralized approach to determine efficient resource allocations would require a central authority to maintain complete knowledge and communication with individual SBSs. Such requirements may not be desirable when we consider randomly deployed large number of individual entities due to computational complexity of centralized solution [36]. For example, consider a SCN with 20 small cells and five channels. In the simplest scenario in which each small cell choosing only one channel for transmission, the number of all possible channel selection profiles is $5^{20} \approx 9.53 \times 10^{13}$, for which it is hard to achieve the optimal solutions using conventional optimization approaches. In order to enable distributed resource allocation, each SBS must be aware of its environment and posses self-organizing ability to cope with interferes. As the numbers and location of SBSs become unpredictable, MNOs should consider distributed network planning approach allowing SBSs to self-organize by learning their environment, and gradually perform resource allocations for their users.

Proper resource allocation management need to consider minimization of interference as much as possible while maximizing the spectral reuse. Resource allocation management for small cells are more complicated with dense and random deployment, as co-existence/ neighboring small cells would create stronger interference and complicate the radio resource allocation process. Resource allocation for SCNs should be dynamic to compensate for varying number of small cells. As a result, the expected benefits from SCNs could be limited if deployed small cells acts non-cooperatively while utilizing the common resources for serving their subscribed users. In such a non-cooperative network, each SBS accounts only for its own QoS while ignoring interference it generates at other SBSs. Here, the interference between small cells becomes a serious problem, as the intensity of small cells increases while the spectrum resources remains limited, that can significantly reduce the network capacity. Without cooper-

ation framework among SBSs, SBSs acting rationally could induce significant interference and result to limited network capacity. Specially, at hot-spots with dense MSs, SCN accumulate extremely high capacity demand and may fail to guarantee proper service to all users if acted upon without cooperation.

The demands of network resources in the wireless cellular networks have grown radically to keep users experience at a satisfactory level, as the mobile usage and contents increase exponentially with new applications. Up to now, the evolution in network architectures, such as in 3G and 4G, have been able to fulfill the ever-increasing needs of high data rates. However, the long anticipated 5G and future networks will need to offer improved coverage and capacity, as well as improved network resource usage, to meet the expectation of networked society with ubiquitous coverage and services availability. This may not be simply obtained from an upgrade of the radio networks. In order to fulfill that, 5G and future networks need to undergo a paradigm shift with improved management of available network resources utilization in order to achieve reliable, ubiquitous, broadband connectivity, and provision of demanding services. This would require some revolutionary changes in network architecture and management policies in order to cope with diverse use case scenarios. A converged environment of multiple operators with provision of multi-operator support through collaboration is necessary to deliver ubiquitous coverage/connectivity requirement from the wireless cellular networks.

1.4 Research Vision, Purpose and Objectives

In wireless cellular networks, area spectral efficiency is used to quantify the spatial spectral utilization efficiency [37]. The radio spectrum is systematically reused at different geometrical areas, i.e. co-channel cells [38], and such co-channel cells are systematically separated by a minimum reuse distance such that their transmissions will not dominantly interfere each other. Area spectral efficiency depends upon factors such as channel access schemes [39] and radio resource management [40]. Since, the system capacity depends on bandwidth, spectral efficiency, and spatial reuse, in this dissertation I look upon to enhance the system capacity of small cell networks through dynamic radio resource management, i.e., with improved area spectral efficiency [5].

The dissertation vision is to improve area spectral efficiency of the small cell networks.

To accomplish the above vision, the dissertation introduces a “cooperative and collaborative

resource management (CCRM)” framework for small cell networks, which belong to multi-operator, to enhance the network spectral efficiency through proper resources utilization along with providing improved user experience.

The objectives of this dissertation are summarized as below.

1. To propose an efficient framework for enabling cooperative and collaborative resource management, i.e., proper radio resource utilization among multi-operator in small cells; (Materials related to this objective appears in Chapter 3, and in publication papers [1], [3], and [7])
2. To advance an efficient cooperative resource allocation scheme within small cell networks of multi-operator; (Materials related to this objective appears in Chapter 4, and in publication papers [1], [2], [4], [5], and [8])
3. To introduce an efficient multi-operator collaboration scheme based small cell networks. (Materials related to this objective appears in Chapter 5, and in publication papers [1], [3], and [7])

1.5 Dissertation Outline

The rest of the dissertation is organized as follows:

- Chapter 2, Background and System Model

In this chapter, first of all some background on small cell networks is presented. Moreover, the technological evolution of small cells features are explained in detail, along with operators’ and subscribers’ perspective towards small cells. Some key technical challenges prevalent in small cell networks are also described. Next, the system model that includes channel model and radio resource scenarios are explained. Finally, brief introduction to several elements of game theory to be considered in this dissertation are provided.

- Chapter 3, Cooperative and Collaborative Resource Management Framework

In this chapter, the framework that enables cooperative and collaborative resource management is introduced, and functionality of its several elements are briefly discussed. First

of all, a general network architecture of multi-operator small cell networks is presented, where benefits associated with this model is explained in detail. Second, a functional architecture for small cells of operators is introduced where small cells are categorized into three groups depending upon their functionality. Finally, the system architecture of cooperative and collaborative resource management framework provides overall control flow for performing cooperative radio resource allocations among small cells of a operator and collaboration formation among multiple operators.

- Chapter 4, Cooperative Resource Allocation Management and Control

In this chapter, I look upon the problem of distributed resource allocation among small cells. Based on game theoretic approach, I consider solution to the problem in both cooperative and non-cooperative small cell networks. I look upon effects of several factors such as: limitation to information exchange and coordination. Most importantly, I propose marginal-contribution-based best-response algorithm, which is proved to be an exact potential game and thus guarantee convergence to steady-state allocation. Through simulations, I verify its performance and significance as compared to other approaches.

- Chapter 5, Collaborative Multi-Operator Management and Control

In this chapter, the collaboration formation process among multiple operators are discussed in detail. First of all, necessary factors to determine the policy profile of an operator is examined. Depending on the policy profile, in order to reach an agreement with other operators for collaboration, the model for negotiation is introduced. The negotiation model is essential in such that it provides opportunity for both participants to reach to an agreement confirming both benefits from collaboration. Simulation results indicates several key aspects of collaboration among multiple operators.

- Chapter 6, Conclusion

In this chapter, I briefly summarize the works in this dissertation and present possible guidelines for future works.

Chapter 2

Background and System Model

2.1 Introduction

Small cells are fully featured, short range BSs used to complement cellular service from larger macrocell BSs. These range from very compact residential femtocells to larger equipment used at commercial offices or outdoor public spaces. They offer excellent mobile phone coverage and data speeds at home, in the office and public areas for both voice and data. Small cells have been developed for both 3G and the newer 4G/LTE radio technologies [34]. Traditionally, the term small cells were used as an “*umbrella term*” that comprised of *micro-*, *pico-* and *femto-* cells, and were used to complement services to users from larger MBSs. Although there were no specific definition of small cells, 3rd generation partnership project (3GPP) had classified them into different categories based on various parameters such as transmit power level, coverage range, number of serviced users and deployment policies [41].

- *Microcells* are small counterparts to the large macrocells, and are usually aimed to enhance capacity in dense urban areas where macrocell coverage is insufficient.
- *Picocells* are relatively low transmit power BSs as compared to microcells, and are typically equipped with omni-directional antennas that can be deployed by operators in both indoor and outdoor hot-spots in a planned manner.
- *Femtocells* are “*plug-and-play*” BSs equipped with omni-directional antennas with much smaller transmit power and coverage range as compared to picocells. They are mostly intended for residential purpose indoor applications that are deployed and managed by

Table 2.1: General cellular network specifications.

	General Cellular Network																							
	Macrocell					Microcell					Pico cell					Femtocell								
Cellular structure	Multi-tier																							
Target coverage	Wide area [42]					Urban [41]					High density suburbs [41]					Indoor office/home [42]								
BS density	Low [42]					moderate [43]					high [43]					very high [43]								
BS installation	Operator [41]															Owner [41]								
BS deployment	Planned [41]															Unplanned [41]								
Transmit power [41] (W)	10 – 50+					1 – 10					0.25 – 1					0.001 – 0.25								
Coverage range [41] (m)	8000 – 30,000					200 – 2000					100 – 200					10 – 100								
Supported MSs [41]	2000+					100 – 2000					30 – 100					1 – 30								
Cellular technology	3G/4G [34]																							
Spectrum band	Licensed [42]																							
Channel bandwidth (MHz) [42]	1.4	3	5	10	15	20	1.4	3	5	10	15	20	1.4	3	5	10	15	20	1.4	3	5	10	15	20
Number of subchannels [42]	6	15	25	50	75	100	6	15	25	50	75	100	6	15	25	50	75	100	6	15	25	50	75	100
Connection	Fiber, DSL, cable and wireless [44, 45]																							

subscribers.

The comparison for some key specifications of general cellular network (above mentioned small cells and macrocell network) is summarized in Table 2.1.

As the underlying femtocell technology expanded to address wider scope, the term small cell was adopted to cover all aspects to work in general for any of the above mentioned technologies. They would incorporate their primary feature, i.e., to assist the macrocell, as well as other small cells. The future cellular networks can be simplified to networks consisting primarily of macrocells and small cells. In more general term, small cells can be coined for a low powered BSs with adaptive footprint, within ten to hundred of meters, which primarily coordinate with each other in vicinity to complement services to mobile users. They will consist of BSs capable of flexible coverage, and their indoor and outdoor deployment offers advantages to cellular coverage and capacity, overcoming penetration losses and assisting with spectrum reuse. In other words, it can be considered as an improvised version of traditional femtocells as summarized in Table 2.2.

Table 2.2: Femtocell and small cell specifications.

	Femtocell						Small Cell					
Target coverage	Indoor						Indoor and outdoor [44]					
BS density	very high						very high [43]					
BS installation	Owner						Mixed of operator and owner [44]					
BS deployment	Unplanned						Mixed of planned and unplanned [44]					
Coverage range (m)	10 - 100						10 – 100 [46]					
Cellular technology	3G/4G						4G and Wi-Fi [47]					
Spectrum band	Licensed						Licensed and unlicensed [47]					
Channel bandwidth (MHz) [42]	1.4	3	5	10	15	20	1.4	3	5	10	15	20
Number of subchannels [42]	6	15	25	50	75	100	6	15	25	50	75	100
Connection	Fiber, DSL, cable and wireless [44, 45]											

2.2 Small Cell Networks

The advancement in wireless technologies with new services and applications have witnessed an exponential growth in network traffic, and to meet those expectations and features bring forth to heterogeneous networks that consists of the traditional macrocells along with other low power nodes. Among other capacity enhancement approaches, network densification, with deployment of large number of small cells through spatial reuse, is considered as the most promising solution to meet the predicted traffic demands [5]. Primarily, the idea of small cell was introduced to reduce the load of macrocell.

The deployment of SBSs are predicted to be much denser than the conventional deployment of MBSs [11], as it offers more flexible deployment opportunities with smaller footprints. BS densification with dense deployment of small cells will decrease load per MBS, as well as provide better link from reduced distance between serving BS and users. This initiates flexibility in deployment and enhance the network performance with improved capacity and area spectral efficiency. This will enable MNOs to extend their network coverage and enhance capacity to the under-served locations and dissatisfied users.

While the coverage can be improved with deployment of small cells at the desired locations, the reduction of cell size can improve the area spectral efficiency, provided that it can achieve high and efficient spectrum reuse. The SCNs fit in by providing MNOs with a cost effective solution to fulfill these requirements as it uses the same interfaces as MBSs. Small cells can backhaul to the cellular operator core network through connections such as fiber, digital subscriber line (DSL), or over a separate dedicated radio frequency (RF) channel. Thus, it can easily integrate, coexist and cooperate with the existing macrocell networks [41].

They are portable and comparatively cheaper alternative to MBSs, with attractive features that includes self-configuring, self-organizing and self-healing capabilities. This means that they are capable to sense, learn and respond according to their dynamic environment. As a result, they can be deployed in desired locations to leverage current infrastructure, while taking users densities, traffic demands and radio propagation conditions into account [44]. This capability favors small cells among operators to achieve overall reduction in infrastructure, maintenance and operational costs.

2.2.1 Small Cells: Over the Years

The concept of home BS (HBS) dates back to 1999 [48] when Alcatel announced a global system for mobile (GSM) based HBS compatible with existing standard GSM phones to be launched into market in 2000. Their demonstration units worked through a plain old telephone system (POTS) line, but were unable to succeed commercially in market due to high deploying and operating cost compared to the advantages they provided at the time. In 2005, the term femtocell was adopted and became recognized as an autonomous and self-adaptive HBS [48]. Eventually, “Femto Forum” (www.femtoforum.org) was formed in 2007 as a non-for-profit membership organization to advocate, regulate and standardize the technology among different vendors, mobile operators and infrastructure manufacturers. Later in 2012, “Femto Forum” were recognised as “Small Cell Forum” (www.smallcellforum.org) to represent femto-cell technology, which was originally designed for indoor home environment, as well as other more general technologies intended for enterprise and outdoor environments [49].

The standardization efforts of small cell technology has been ongoing since 3GPP release 8. 3GPP release 8 introduced closed subscriber group (CSG) access control, an important functionality that allows only subscribed users to connect to the small cell [50]. All request from

unauthorized users are rejected such that only subscribed users of the CSG can access the small cell. Later in 3GPP release 9, open subscriber group (OSG) access mode and hybrid access mode were added to the list of access modes [50]. In open access mode, all users are treated equally and allowed to access a small cell to benefit from its service. While in hybrid access mode, unsubscribed users not in the CSG can get limited service from a small cell, with preference given to the subscribed users.

Interference management functionality was subsequently introduced enabling increased spectral efficiency that can be achieved. ICIC [51] was introduced in 3GPP release 8 to reduce interference at the cell edges, which was later evolved to enhanced ICIC (eICIC) and feICIC. ICIC enabled small cells to communicate via the X2 interface to mitigate inter-cell interference by optimizing scheduling for users at the cell edges. Both, eICIC (introduced in 3GPP release 10) and feICIC (introduced in 3GPP release 11), uses cell range expansion (CRE) technique to increase the coverage area and reduce interference at the cell edge of small cells. The major change introduced in eICIC is the addition of time domain ICIC, which is realized through use of almost black subframes (ABSs). ABS includes only control channels and cell-specific reference signals, no user data, and is transmitted with reduced power. When eICIC is used, the macrocell transmits ABS according to a semi-static pattern. The macrocell informs small cells about the ABS pattern so that it can serve its users, typically in the CRE region, during these subframes. Such capabilities allow users to be offloaded from the macrocell to the small cell. feICIC focuses on interference handling through inter-cell interference cancellation for control signals, enabling even further CRE.

CA was introduced in 3GPP release 10 [52], to increase the total bandwidth available to users. Some simple concept of CoMP were introduced in 3GPP release 11 [53]. CoMP coordinates transmission and reception between different transmitting and receiving BSs through the use of load balancing, coordinated scheduling, and transmit power control. Through CoMP, a number of transmission/reception points (i.e., small cells or RRHs) can be coordinated to provide service to a user. However, it requires that the BSs are synchronized.

Recently, network sharing was introduced in 3GPP release 13 [54], where two approaches were introduced: *multiple operator core network* (MOCN) and *gateway core network* (GWCN). It enables multiple operators to share their network resources. While MOCN configuration considers only the RAN elements to be shared, GWCN configuration allows operators to share

both RAN and core network functions.

2.2.2 Operators' and Subscribers' Perspective

Considering the demand to meet an exponentially growing data rate, operators are striving to adopt networks that can increase coverage and reuse spectrum in cost effective fashion. As mentioned earlier, network densification with small cells can enable MNOs to improve coverage as well as area spectral efficiency. Moreover, as small cells are integrated into the overlaying macrocell networks, they rely on the existing network resources and infrastructures. This reduces the CAPEX for new site installation and spectrum acquisition in SCNs. Moreover, SBSs are connected to the operator's core network via IP based backhaul. It saves the backhaul cost for operator since the traffic can be carried over existing wired broadband connections.

More generally, SCNs can be characterized by the deployment of large number of BSs, whose coverage footprint is much smaller to that of the macrocell. Depending upon the use cases, the SCNs can be deployed indoor, outdoor, and the combination of indoor and outdoor [41]. Small cells are categorized into three different location-centric categories: residential for home applications, enterprise/indoor for small business, and outdoor for users in public places.

The installations of SBSs can be either by operators or subscribers, which in turn can be combination of planned and unplanned deployment depending upon the use cases. Moreover, SBSs are intended to be "plug-and-play" devices, that are facilitated with self-configuration and self-recovery features to overcome failures. This will allow them to autonomously adapt to the changes in their environment.

They can operate in both licensed and unlicensed spectrum over a range of of hundreds of meters in urban areas as compared to kilometers in some rural areas with low density population. Restrictions can be applied on who can access to a small cell, open or restricted access. The access policy to small cells can either be open to all users, limited only to subscribed users, or hybrid, where conditional access to small cells are allowed to unsubscribed users.

Table 2.3 summarizes some of the key important benefits of small cells from the perspective of subscribers and operators.

From operators' point-of-view, small cells promotes expansion of their radio networks, in terms of coverage and capacity, without any need for investment in new equipment and infrastructures, such as acquisition of new sites, installation of BSs towers or expansion of backhaul.

Table 2.3: Benefits of small cells from the perspective of operators and subscribers.

Operators	Subscribers
Lower CAPEX	Increased data rate
Lower operational expenditure	Lower end-to-end latency
Offload macrocell traffic	Seamless connectivity
Increased spectrum reuse	Increased security
Increased coverage and capacity	Ability for access modes
Lower power consumption	Improved macrocell indoor coverage as relay node

At the mean time, other operational expenses are low, such as the energy consumption at the radio network is limited. It helps MBSs by increasing system capacity, such as by offloading portion of those traffics originating from indoor. Moreover, the system capacity increases in terms of spectrum, since the available spectral resources are reused more frequently.

From the subscribers' point-of-view, small cells help to bring the BSs closer to the users. It achieves increased data rates and lower end-to-end latency as compared to the conventional macrocell networks. It has significance at indoor locations where macrocellular signal strength is poor and mobile connectivity is limited, thus improving both data and voice rate services. As it can be used as a relay node, subscriber can extend the macrocellular coverage by using his/her own small cells. It also offers increased security along with the capability to operate in different access modes, thus enabling selected group with access permissions.

2.2.3 Technical Challenges

The massive and random deployment of small cells give rise to several technical challenges. Since the SBSs can be deployed by subscribers, the location of SBSs are randomly distributed and their coverage area may overlap. Moreover, due to dense deployment of small cells, centralized coordination mechanisms among small cells are unfeasible. With such dense deployment, small cells require high immunity to interference that is prevalent in cellular networks because the spectral resources are limited and usually shared. As a result, random deployment of small

cells within macrocell coverage, particularly with co-channel spectrum allocation, give rise to severe interference issues. The resource allocation management in SCNs become quite different than in conventional cellular networks because of aforementioned issues. Hence, efficient resource allocation for interference management is a critical issue as it affects both system capacity and cellular coverage restrictions [20]. This in turns create a challenging problem for operators to manage their network resources efficiently in order to achieve desired gains from small cells deployment.

Some of the key challenges in SCNs include access policy, self organization, handover and mobility management, resource allocation and interference management, etc. The overview of some technical challenges occurring in SCNs are provided here.

Access Policy

How should a dense SCNs provide access to users? In closed access mode, small cells has limited subscription to only subscribed users providing privacy and security. Any unsubscribed users near small cell receiving high signal level would experience interference [20]. While open access mode provide resource allocation to unsubscribed nearby macrocell users. Open access mode is more likely to be a preferable choice at public places, rather by paying home users requiring to share his/her resources. A simple approach for cell association in such mode would be to assign users to the SBSs with highest signal level. Hybrid access mode provides access to certain unscribed users with nearby small cell resources. But the subscribed users get to have more preference over the unsubscribed users' level of service. Preferential charging and preferential treatment for subscribed users over unsubscribed users is presented in [50]. However, increasing the number of outsiders to access small cell resources would have negative performance experience to the subscribed users. Beside providing opportunity to reduce macrocell load, the higher number of users can increase traffic at the backhaul while raising privacy concerns to subscribed users [5]. Moreover, the availability of spectral resources at the serving SBS remains a strong limiting factor for granting access to large number of users. SBSs should be able to optimize the number of users maintaining performance priority of subscribed users. Such that any service to unsubscribed users should be rejected or handed over to macrocell or other SBSs, giving priority to the subscribed users. Nevertheless, the admission of a user to small cells is conditional to the access policy and the availability of spectrum resources at the

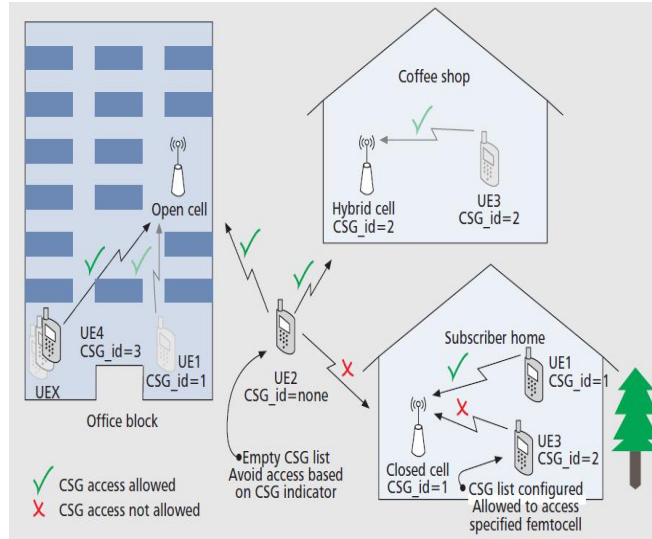

Figure 2.1: Access policy for UEs in SCN [50].

servicing SBS. Figure 2.1 illustrates the three access modes in small cell environment.

Self Organization

The number and positions of small cells within/outside a macrocell coverage area are random and are not location constrained. They must support “plug-and-play” operation with capability to self organize for enabling efficient scalable deployment and maintenance [55]. Self organization in small cells will reduce the OPEX for SCNs. Self organization in SCNs mainly comprises of *self configuration*, *self optimization* and *self recovery* [42]. Self configuration for small cells will be required whenever adding or moving to a new site, rebooting and modifying network features. Configurations to basic parameters such as pilot transmit power and neighbor list needs to be performed before operation and optimization. Self optimization is a continuous phase of accessing to information on network parameters (such as transmit power, resources, access modes, handovers, etc) and guarding small cells to be operating at an acceptable level. Self recovery process is required to resolve problem occurred due to unpredictable events and proceed the small cells back to normal operation. Such self organization operations would minimize the human intervention for proper network operation, and that would in return provide with significant reduction in the operational and maintenance costs.

Handover and Mobility Management

An efficient handover and mobility management scheme in SCNs (among small cell-to-small cell) would be necessary for mass deployment of small cells [56]. Several handover mechanisms are proposed taking into account multiple comparing factors such as service quality and speed of users [57], and received signal strength (RSS) and velocity of users [58]. The number of handovers taking place in open access would be significantly large as compared to closed and hybrid modes. While channel fluctuations may cause a passing user under open access mode of small cell to perform multiple handovers. To minimize such multiple handovers to take place, [35] proposes reducing the pilot power when no active users are present. The schemes should be able to reduce signaling and network complexity, deal with different access policies and provide with proper resource allocation beforehand to perform efficient handover.

Resource Allocation and Interference Management

Interference management among neighboring small cells is considered as one of the most important technical challenges in SCNs. The dense deployment of small cells, with co-channel deployment is a preferable choice among operators for improving overall system capacity and reusing the available spectral resources. With such deployment, SCNs would require high immunity to interference that is prevalent in cellular networks, because the spectral resources are limited and shared [59]. Interference at both co-tier (between small cells) and cross-tier (between small cells and macrocells) possess an increasingly severe threat as deployment of small cells becomes denser in urban environment, consisting of dense population of network users [42]. The dense and random deployment of small cells, particularly with co-channel spectrum allocation, would give rise to severe interference issues. This in turn becomes a challenging problem for MNOs to manage spectrum allocation, as proper resource allocation is a critical issue as it affects both system capacity and cellular coverage restrictions. Distributed resource allocation schemes are required that could satisfy the QoS requirements of the small cell users and at the same time enhance the capacity and coverage of the SCN.

Thus, SCNs are a paradigm shift from the conventional cellular network and pose many new challenges in optimal performance. In this context, I address proper management of resources to enhance the area spectral efficiency in SCNs. In the rest of the dissertation, I model, analyze and study for efficient schemes for resource allocations in SCNs (both single and multi-operator). I

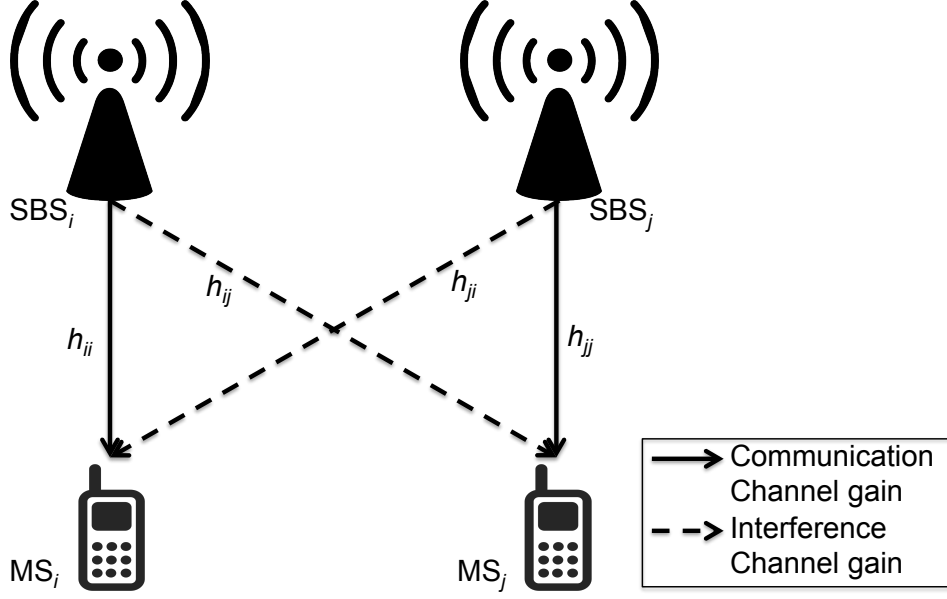

Figure 2.2: System model.

use game theoretic approach to model for strategic interactions and resource allocations among small cells in a neighborhood.

2.3 System Model

2.3.1 System Model

I consider downlink subchannel allocation in an orthogonal frequency division multiplexing (OFDM) based SCN that consists of downlink transmission links from the transmitting SBS to the receiving MS as shown in Figure 2.2. Let $\mathcal{N} = \{1, \dots, N\}$ be the set of SBSs, and $\mathcal{M} = \{1, \dots, M\}$ be the set of MSs. Then, $\forall n \in \mathcal{N}$, $\mathcal{M} = \bigcup_{n=1}^N \mathcal{M}_n$, and $M_n = |\mathcal{M}_n|$ is the number of MSs associated with SBS n . Here, a link $i \in \mathcal{M}$ is between one transmitting SBS and one receiving MS. Hence, the total number of links corresponds to M . Channel bandwidth B of the OFDMA network is divided into K subchannels. The set of subchannels are denoted as $\mathcal{K} = \{1, \dots, K\}$, with each subchannel having bandwidth of B/K .

Consider $h_{ii,k}$ be the channel gain for transmission on link i (i.e., the channel gain of the transmitting SBS for link i to the receiving MS of link i on subchannel $k \in \mathcal{K}$). Hence, $h_{i'i,k}$ represents the channel gain of the interference from the transmitting SBS for link i' to the receiving MS of link i on subchannel k .

In this work, I consider the physical interference model, which takes into account interference produced by all other links. Here, I assume that SBS n transmit simultaneously to multiple MSs, $M_n \in \mathcal{M}_n$, using OFDM subchannels, and each MS uses only one subchannel. The maximum transmit power, P_{max} , of SBS is divided equally among the subchannels. Hence, the transmit power for link i on subchannel k from transmitting SBS n is given by

$$P_{i,k} = \frac{P_{max}}{\min\{M_n, K\}} \quad (2.1)$$

where, $\min\{M_n, K\}$ is the active number of subchannels. Now, the downlink SINR for link i on subchannel k is given by

$$\gamma_{i,k} = \frac{P_{i,k}h_{ii,k}}{I_{i,k} + \sigma^2} \quad (2.2)$$

where $I_{i,k}$ is the downlink co-channel interference of link i on subchannel k , i.e., $I_{i,k}$ is the sum of the co-channel interference from all other links using the same subchannel k ,

$$I_{i,k} = \sum_{i' \neq i} P_{i',k}h_{i'i,k} \quad (2.3)$$

and σ^2 is the additive white Gaussian noise (AWGN) power.

From Shannon theory, the capacity for link i on subchannel k is

$$C_{i,k} = \frac{B}{K} \log_2(1 + \gamma_{i,k}) \quad (2.4)$$

Summing the capacity over all links and over all subchannels, total capacity of the network is given by

$$C = \sum_i \sum_k C_{i,k} \quad (2.5)$$

2.3.2 Radio Resource Scenarios

Three general radio resource scenarios in a SCN can exist depending upon number of subchannels and MSs associated per SBS as illustrated in Figure 2.3.

The first scenario in Figure 2.3 (a), *sparse*, consists of SBSs such that the number of subchannels are greater than MSs per SBS i (i.e., $K > M_i$) for all $i \in \mathcal{N}$.

The second scenario in Figure 2.3 (b), *moderate*, consists of SBSs such that the number of subchannels are less/equal to MSs per SBS i (i.e., $K \leq M_i$) and the number of subchannels are greater than MSs per SBS j (i.e., $K > M_j$), for all $i, j \in \mathcal{N}$.

Finally the third scenario in Figure 2.3 (c), *dense*, consists of SBSs such that the number of subchannels are less/equal to MSs per SBS i (i.e., $K \leq M_i$) for all $i \in \mathcal{N}$.

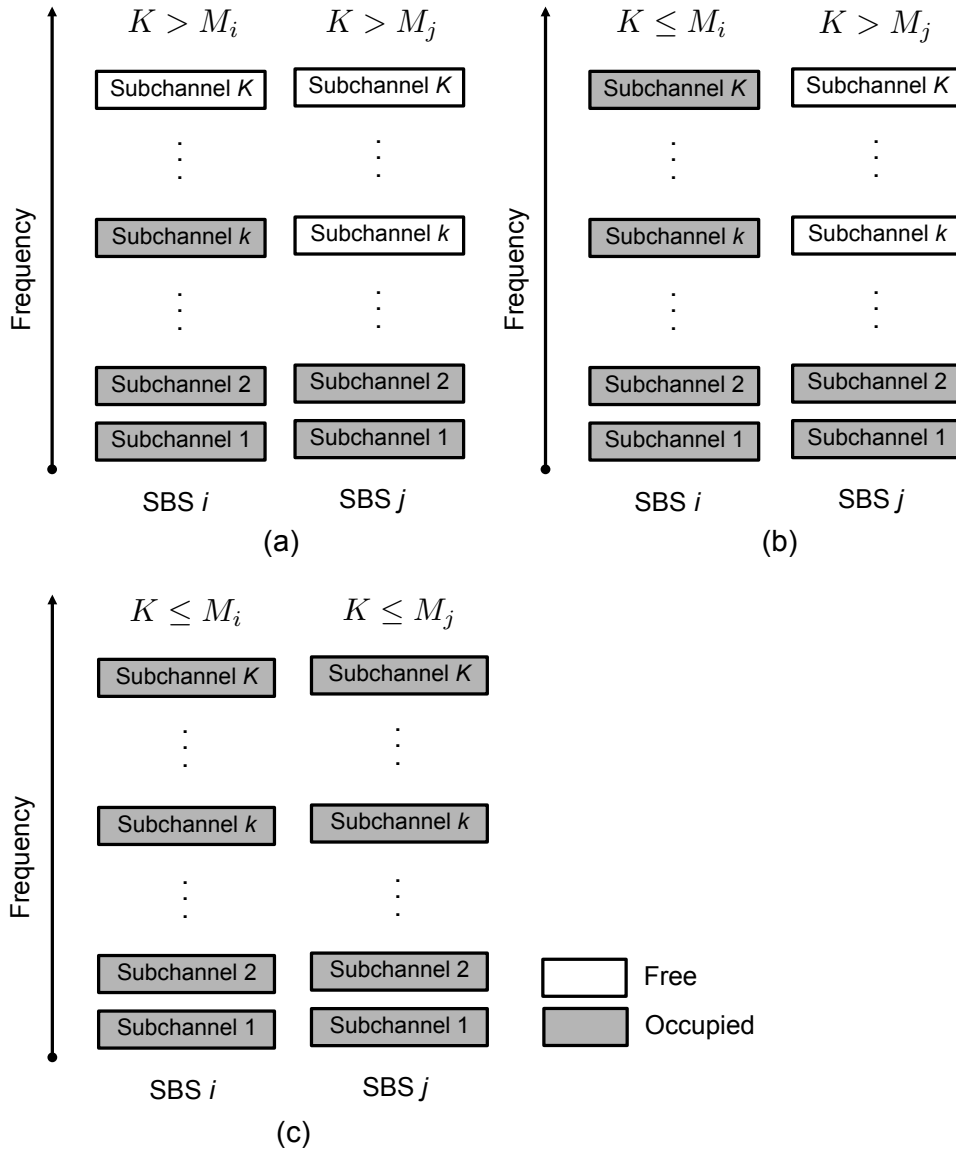

Figure 2.3: Radio resource scenarios: (a) sparse, (b) moderate, and (c) dense.

2.4 Game Theoretic Framework

Game theory (GT) [60] represents a branch of mathematics, which analyzes models of optimal decision-making in condition of conflicts. In short, GT is a study of rational decision-makers' strategic interactions. It had been used primarily in economics for modeling competition between companies. However, its applications range appears much wider, from operational research (a science originally intended for planning and conducting military operations) to areas of politics, biology and more. John von Neumann and Oskar Morgenstern introduced an idea of general theory of games, which proposed that most economic questions should be analyzed

as games in there 1944 book: *Theory of Games and Economic Behavior* [61].

Depending on the number of players, a game can be *zero-sum* game and *non-zero-sum* game [60]. Strategy sets of decision-makers can be finite or infinite. Also, decision-makers can act independently or form coalitions; the corresponding models represent *non-cooperative* games and *cooperative* games respectively. Decision-makers in the game can have complete or partial incoming information. Generally, the solution of a game is called an *equilibrium*, a steady-state, while one can choose among various concepts of an equilibrium (such as *Nash equilibrium* and *correlated equilibrium* [60]).

2.4.1 Non-Cooperative and Cooperative Games

A game can be either *non-cooperative* or *cooperative* based on the behavior of players [62]. Every player's incentive is to maximize their payoffs. In a cooperative game, players form agreement and their strategy involves payoffs obtained among themselves [63]. The players in cooperative game form group or subgroups among themselves as the unit of analysis through necessary cooperative agreements. While in non-cooperative games, players' actions do not concern for payoffs of others, i.e., they act in their self interest, such that they are motivated for their own best outcome in the game [62]. The players in non-cooperative games are selfish, each looking to improve its own payoff and not taking into account others involved in the game.

So, non-cooperative GT studies strategic actions that results from interactions among rational players, where each player's action is to improve own performance (utility) or reduce own loss (costs). On contrary, cooperative GT describes outcomes that result when the players come together in different combinations. The main branch of cooperative games describes the formation of cooperating groups of players, referred to as *coalitions*, which can strengthen the players positions in a game [63].

2.4.2 Preliminary Definitions

A basic notion of GT comprises of *players* (decision-makers), *strategies* (actions), and *payoffs* (utilities).

Formally, a game is defined as $\mathcal{G} = \langle \mathcal{I}, \{\mathcal{S}_i\}_{i \in \mathcal{I}}, \{u_i\}_{i \in \mathcal{I}} \rangle$, or simply, $\mathcal{G} = \langle \mathcal{I}, \{\mathcal{S}_i\}, \{u_i\} \rangle$, where

- $\mathcal{I} = \{1, \dots, I\}$ is the set of players,

		Al	
		<i>Quiet</i> (s_1)	<i>Fink</i> (s_2)
Bob	<i>Quiet</i> (s_1)	3, 3	0, 5
	<i>Fink</i> (s_2)	5, 0	1, 1

Figure 2.4: *Prisoners' dilemma* game.

- \mathcal{S}_i is the set of strategy (actions) for each player $i \in \mathcal{I}$, and
- u_i is the payoff received by player $i \in \mathcal{I}$.

The strategy profile $\mathcal{S}_{\mathcal{I}}$ consists of all players' strategies, i.e., $\mathcal{S}_{\mathcal{I}} = \prod_{i \in \mathcal{I}} \mathcal{S}_i$. For $s_i \in \mathcal{S}_i$, $\mathbf{s} = (s_i)_{i \in \mathcal{I}} \in \mathcal{S}_{\mathcal{I}}$, such that $\mathbf{s} = (s_i, \mathbf{s}_{-i}) = (s_1, \dots, s_I) \in \mathcal{S}_{\mathcal{I}}$, and $\mathbf{s}_{-i} = (s_1, \dots, s_{i-1}, s_{i+1}, \dots, s_I) \in \mathcal{S}_{\mathcal{I} \setminus \{i\}}$, where players other than some given player i is denoted by $-i$.

Throughout the work in this dissertation, I consider the set of \mathcal{M} players, i.e. SBS to MS links, where players other than some given player i is denoted by “ $-i$ ”. The strategy $\mathcal{S}_i = \{1, 2, \dots, K\}$ is a set of available actions (subchannels) for each player $i \in \mathcal{M}$. The strategy profile $\mathcal{S}_{\mathcal{M}}$ consists of all players' strategies, i.e., $\mathcal{S}_{\mathcal{M}} = \prod_{i \in \mathcal{M}} \mathcal{S}_i$. For $s_i \in \mathcal{S}_i$, $\mathbf{s} = (s_i)_{i \in \mathcal{M}} \in \mathcal{S}_{\mathcal{M}}$, such that $\mathbf{s} = (s_i, \mathbf{s}_{-i}) = (s_1, \dots, s_M) \in \mathcal{S}_{\mathcal{M}}$, and $\mathbf{s}_{-i} = (s_1, \dots, s_{i-1}, s_{i+1}, \dots, s_M) \in \mathcal{S}_{\mathcal{M} \setminus \{i\}}$. For simplicity, I use \mathcal{S} and \mathcal{S}_{-i} to denote $\mathcal{S}_{\mathcal{M}}$ and $\mathcal{S}_{\mathcal{M} \setminus \{i\}}$ respectively. The utility function of player i , $u_i : \mathcal{S}_i \rightarrow \mathbb{R}$, maps the strategy profile to a real value \mathbb{R} , which indicates the preferences over the set of strategy profiles.

The example of *Prisoners' dilemma* [60] below shows a game with set of two players and two strategies.

Example 2.1 (*Prisoners' dilemma*): Consider a game \mathcal{G} with two suspects (Bob and Al) of a major crime are held in separate cells. The detective do not have enough evidence to convict either of them of the crime unless one of them acts as an informer against the other (finks). If they both stay quiet, each will be released, and split the proceeds of their crime. If only one of them finks to witness against the other, he will be freed and use entire proceeds of the crime. If both of them finks, then both of them are convicted but given a reduced term. The game is represented in Figure 2.4, the two rows correspond to the possible strategies of Bob, the two columns corresponds to the two possible strategies of Al, and the numbers in each box are the payoffs to the corresponding strategy profile, with Bob's payoff listed first.

Now given opponents' strategies, player i selects a strategy among all available strategies

such that its own utility is maximized, i.e., player i prefer strategy s_i to s'_i if $u_i(s_i, \mathbf{s}_{-i}) \geq u_i(s'_i, \mathbf{s}_{-i})$. Such a strategy is called *best-response* strategy of i which is defined as follows.

Definition 2.1: [64] The *best-response* (BR) strategy, $br_i(\mathbf{s}_{-i})$, of player i to the profile of strategies \mathbf{s}_{-i} played by all other opponents, where $\mathbf{s}_{-i} = (s_1, \dots, s_{i-1}, s_{i+1}, \dots, s_M)$, is a strategy s_i such that,

$$br_i(\mathbf{s}_{-i}) = \arg \max_{s_i \in \mathcal{S}_i} u_i(s_i, \mathbf{s}_{-i}) \quad (2.6)$$

where u_i is the utility of player i and \mathcal{S}_i is the set of possible strategies of player i .

Now, for the *Prisoners' dilemma* game, preference orderings for Bob denoted by utility function u_1 is

$$u_1(Fink, Quiet) > u_1(Quiet, Quiet) > u_1(Fink, Fink) > u_1(Quiet, Fink)$$

Similarly, the preference orderings for Al denoted by utility function u_2 is

$$u_2(Fink, Quiet) > u_2(Quiet, Quiet) > u_2(Fink, Fink) > u_2(Quiet, Fink)$$

Given that there exists mutual BR strategies, then no player will have incentive to deviate from their strategy profile. *Nash equilibrium* (NE) is a fundamental solution concept in GT that indicates a steady-state condition of such strategy profiles which is defined as follows

Definition 2.2: [60] A strategy profile $\mathbf{s}^* = (s_1^*, \dots, s_M^*)$ constitutes a *Nash equilibrium*, if it satisfies the following condition

$$u_i(s_i^*, \mathbf{s}_{-i}^*) \geq u_i(s_i, \mathbf{s}_{-i}^*), \forall s_i \neq s_i^*, \forall s_i \in \mathcal{S}_i, \forall i \in \mathcal{M} \quad (2.7)$$

equivalently, $s_i^* \in br_i(\mathbf{s}_{-i}^*)$ for all $i \in \mathcal{M}$.

At NE, no player can improve its payoff by adopting a different strategy unilaterally, thus a stable-state is obtained where no player has an incentive to unilaterally deviate. Now, according to equations 2.6 and 2.7, the corresponding NE for the *Prisoners' dilemma* game is $(Fink, Fink)$.

Although NE is a solution concept for many games, when players update their strategy sequentially under BR dynamics, the existence of pure strategy NE is not always guaranteed [64], as shown in example 2.2 below.

Example 2.2: Consider a subchannel selection problem in the SBS and MS pairs arrangement shown in Figure 2.2. Let $\mathcal{N} = \{1, 2, 3\}$, $\mathcal{K} = \{1, 2\}$, $\mathcal{M} = \{1, 2, 3\}$ and $M_n = 1$ for all

$n \in \mathcal{N}$. Let h_{11}, h_{22} , and h_{33} be the channel gains for transmission, and the channel gains of interference given by $h_{21} > h_{31}, h_{32} > h_{12}$, and $h_{13} > h_{23}$. Let (2.2) be the utility function to be maximized by link $i \in \mathcal{M}$, such that

$$u_{1_i}(s_i(t) = k) = \gamma_{i,k} \quad (2.8)$$

The utility function in (2.8) corresponds to the utility obtained by link i on subchannel k assuming $\mathbf{s}_{-i}(t) = \mathbf{s}_{-i}(t-1)$, i.e., all other links continue to use the subchannel selected in previous time-slot. This subchannel selection game $\mathcal{G}1 = (\mathcal{M}, (\mathcal{K}_i), (\gamma_{i,k}))$ has 8 possible subchannel selection strategy profiles, (s_1, s_2, s_3) ; two *same-subchannel* profiles are $(1, 1, 1)$ and $(2, 2, 2)$, and six *mixed-subchannel* profiles are $(1, 1, 2), (1, 2, 1), (1, 2, 2), (2, 1, 1), (2, 1, 2)$ and $(2, 2, 1)$.

Case I: If initially at time-slot $t = 0$, consider a same-subchannel profile, say $(s_1, s_2, s_3) = (1, 1, 1)$, then all links have an incentive to change subchannel at next time-slot $t = 1$ since $br_i(s_{-i}) = \{2\}, \forall i \in \mathcal{M}$. This will change the strategy profile $(1, 1, 1)$ to any one of the mixed-subchannel profiles: $(1, 1, 2), (1, 2, 1)$ or $(2, 1, 1)$, depending on which link makes the subchannel switching first.

Case II: If initially at time-slot $t = 0$, consider a mixed-subchannel profile, say $(s_1, s_2, s_3) = (1, 1, 2)$, then at next time-slot $t = 1$, link 1 has an incentive to change to subchannel 2 since $br_1(s_{-1}) = \{2\}$. The sequence of subchannel switching is $(1, 1, 2) \rightarrow (2, 1, 2) \rightarrow (2, 1, 1) \rightarrow (2, 2, 1) \rightarrow (1, 2, 1) \rightarrow (1, 2, 2) \rightarrow (1, 1, 2) \rightarrow \dots$; i.e., it does not converge to a pure strategy NE. Moreover, none of the six mixed-subchannel strategy profiles can satisfy (2.7). The subchannel selection game $\mathcal{G}1$ does not converge to a pure strategy NE.

2.4.3 Potential Games and its Characteristics

To guarantee that a game converges to a pure strategy NE, Monderer and Shapley introduced a class of strategic form games called *Potential game* (PG) [65], which following sequential play under BR dynamics converge to a pure strategy NE. Moreover, a class of PG called *exact potential game* (EPG), which has at least one pure strategy NE is characterized by the existence of a potential function, a global objective function $\mathbf{P} : \mathcal{S} \rightarrow \mathbb{R}$, with property,

$$u_i(s_i, \mathbf{s}_{-i}) - u_i(s_{i'}, \mathbf{s}_{-i}) = \mathbf{P}(s_i, \mathbf{s}_{-i}) - \mathbf{P}(s_{i'}, \mathbf{s}_{-i}), \quad (2.9)$$

for all $i \in \mathcal{I}, s_i, s_{i'} \in \mathcal{S}_i$, and $\mathbf{s}_{-i} \in \mathcal{S}_{-i}$. Here, the potential function acts as a global performance indicator and tracks change in utilities when some player changes their strategy. It

reflects that change in a player's utility from unilateral deviation in strategy is exactly equal to the change in the potential function. Moreover, in an EPG, the potential function is unique except for an additive constant, and pure strategy NE corresponds to maxima of the potential function [65].

Considering the *prisoners' dilemma* game \mathcal{G} , the matrix $\mathbf{P} : \mathcal{S} \rightarrow \mathbb{R}$ is the potential function for \mathcal{G} as described below:

$$\mathbf{P} = \begin{pmatrix} 0 & 2 \\ 2 & 3 \end{pmatrix}$$

Since, \mathbf{P} admits a maximal value in its strategy profile \mathcal{S} , and \mathcal{G} with potential \mathbf{P} satisfies the condition of (2.9), hence the *prisoners' dilemma* game \mathcal{G} possesses a pure strategy NE, i.e., the strategy $(Fink, Fink)$.

2.5 Summary

In this chapter, some detail backgrounds on small cell networks were presented that mainly includes: evolution of small cells, its benefits towards the operator and subscribers, and technical challenges prevalent while considering deployment of small cells. The considered system model for this dissertation was introduced, which included channel model and radio resource scenarios. Finally, game theoretic framework was briefly explained in details. Here, introduction to several components of game theory, concept of best response strategy and pure strategy Nash equilibrium, and potential games with its characteristic features were explained in details.

Chapter 3

Cooperative and Collaborative Resource Management Framework

3.1 Introduction

Traditionally, small cells are mainly deployed for a single MNO. The current SCNs deployment scenarios (for both indoor and outdoor locations) only support subscribers of one operator [66], which means that with multiple MNOs present in one location, the subscribers are isolated to separate cells of their respective operators. Compatibility with multiple MNOs is desirable for SCNs as the small cells move from residential deployment towards public hot-spots such as enterprises.

Cisco's VNI analysis for global mobile data traffic forecast [1] predicts that by 2020, 96% of all data will be consumed from indoor locations, such as residential buildings and enterprises as shown in Figure 3.1. Moreover, of over 500 enterprises surveyed worldwide, more than 50% want their SCNs to support services from 2 – 3 MNOs, while the lack of multi-operator small cells support was reported as a significant barrier to SCNs adoption by them [66]. Multi-operator small cell is defined as a single small cell that can support coverage for multiple operators' networks in the spectrum of just one [66]. This could potentially overcome limitations in the general indoor enterprises' environment, where the customers who are accessing services from other MNOs in contrast to enterprises in contract with a particular MNO, are barred to access available small cell's services.

The small cell users with multi-operator support could access to wireless connectivity any-

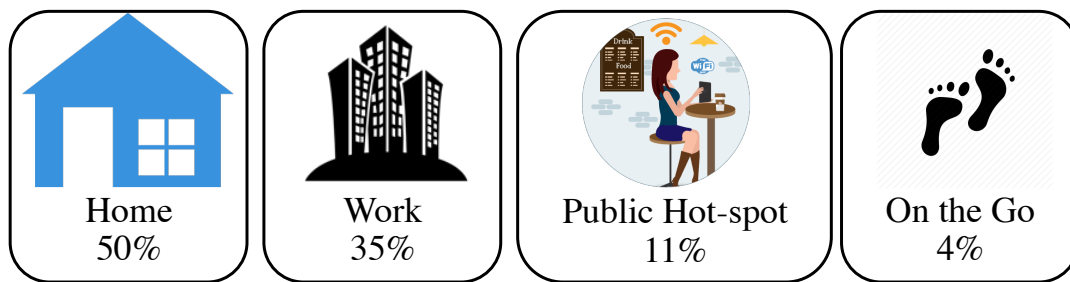

Figure 3.1: Data consumption estimation, Cisco VNI (2015 – 2020).

where, regardless to their MNO's network, and this in turn will enable them with an uninterrupted services. This necessitates those enterprise to require support of multi-operator networks in order to support and serve their customers by enabling a bring-your-own-device (BYOD) environment [67]. The BYOD environment would enable everyone to be able to connect wirelessly regardless of their parent MNO's service/coverage and maintain ubiquitous mobile usage. Without multi-operator small cells support, the above service requirements of small cell users will be severely limited, and also delay the expected deployment rate of small cells [66].

With multi-operator enabled small cells' environment, whenever a MNO could host subscribers that belong to other MNOs, it takes on the responsibility to provide them with service from their own network resources and maintain the desired level of services to those subscribers. And, in return the MNO would expect potential returns for their services. The hosting MNO may monetize for services they provide to their competitors' subscribers. This would in turn also create a favorable BYOD environment for a MNO, where the MNO's SCN can support wide range of subscribers irrespective of their own subscribers whenever the resource allocation is favorable and increase their revenues as well. Such collaboration among MNOs can provide them with an uninterrupted on-demand service to subscribers and improved revenues, to the parent MNO and potential host MNO respectively. However, it would require proper negotiation to maintain a balance between benefits that are acceptable to all parties involved, i.e., *win-win* policy for the collaborating MNOs.

The decision by MNOs to consider network resources sharing involves technical aspects as well as other regulatory aspects [68, 69]. MNOs with exclusive rights to spectrum would have little incentive to share their precious spectrum with other MNOs despite significant research and regulatory efforts, as the mobile market is mainly characterized by high upfront cost of acquiring spectrum licenses [70]. However, considering high cost, spectrum scarcity and spectrum

under-utilization, it can be expected that efficient collaboration could be beneficial for MNOs in terms of coverage and revenues (which mainly depends on spectrum utilization). In this chapter, I introduce: (i) a general network architecture of multi-operator SCNs, (ii) a functional architecture of a MNO's SCNs, and (iii) a system architecture for cooperative and collaborative resource allocation among multiple MNOs. The concept of multi-operator collaboration is to be performed at MNOs' C-RANs such that the radio networks' edge resources, both spectrum and infrastructures of a MNO, can be used to serve subscribers of other MNOs.

3.2 Background

3.2.1 Long Term Evolution Architecture

The long term evolution (LTE) architecture consists of two networks: *radio* network and *core* network. The radio network is called LTE, whereas the core network is called system architecture evolution (SAE)^a.

The LTE architecture is introduced in 3GPP specification 36.401 [71] and is based on flat architecture, which means that it consists of only one element type for the radio network and the core network [72]. In the overall LTE-EPC division, LTE refers to evolved UMTS terrestrial radio access network (E-UTRAN) and EPC refers to evolved core network as shown in Figure 3.2 (b). Figure 3.2 demonstrates differences from the 3G basic architectural concept. The evolved packet system (EPS) consists of E-UTRAN and EPC as shown in Figure 3.3. E-UTRAN is an evolution of the 3GPP UMTS terrestrial radio access network (UTRAN) technology, and contains only one type of node, eNodeB, which provides the air interface to UE.

Noticeably, unlike in UTRAN, eNodeBs are connected to each other via the X2 interface. EPC consists of three elements: *serving gateway* (S-GW), *packet data network gateway* (P-GW), and *mobility management entity* (MME). eNodeBs are connected to MMEs and S-GWs via S1 interface for traffic and control purposes respectively. Each eNodeB connects to MME via S1-MME interface and to S-GW via S1-U interface.

The S-GW provides user plane connectivity between UE and P-GW. Some main functionalities that is handled by S-GW are as follows [51]:

^aSAE was used at the beginning of the standardization, however, nowadays the official standard term for core network is evolved packet core (EPC)[71].

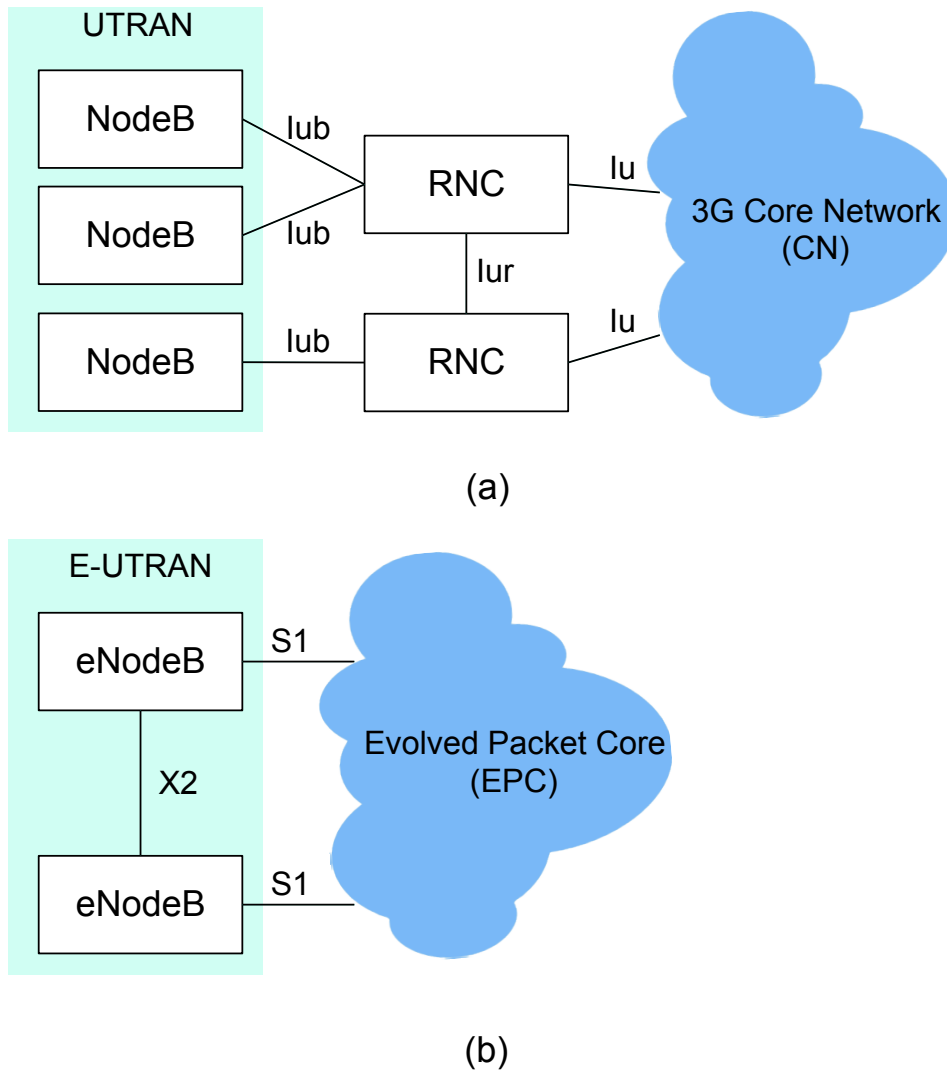

Figure 3.2: The architectural difference between (a) UTRAN and (b) E-UTRAN.

- Acts as a local anchor point for inter-eNodeB handovers;
- Acts as an anchor point for inter-3GPP network mobility;
- Packets routing and forwarding;
- Handles packet buffering in E-UTRAN idle mode;
- Handles network initiated service request procedure;
- Packet marking at the transport level for both DL and UL;
- Accounting on user and QoS class identifier for the inter-operator charging processes.

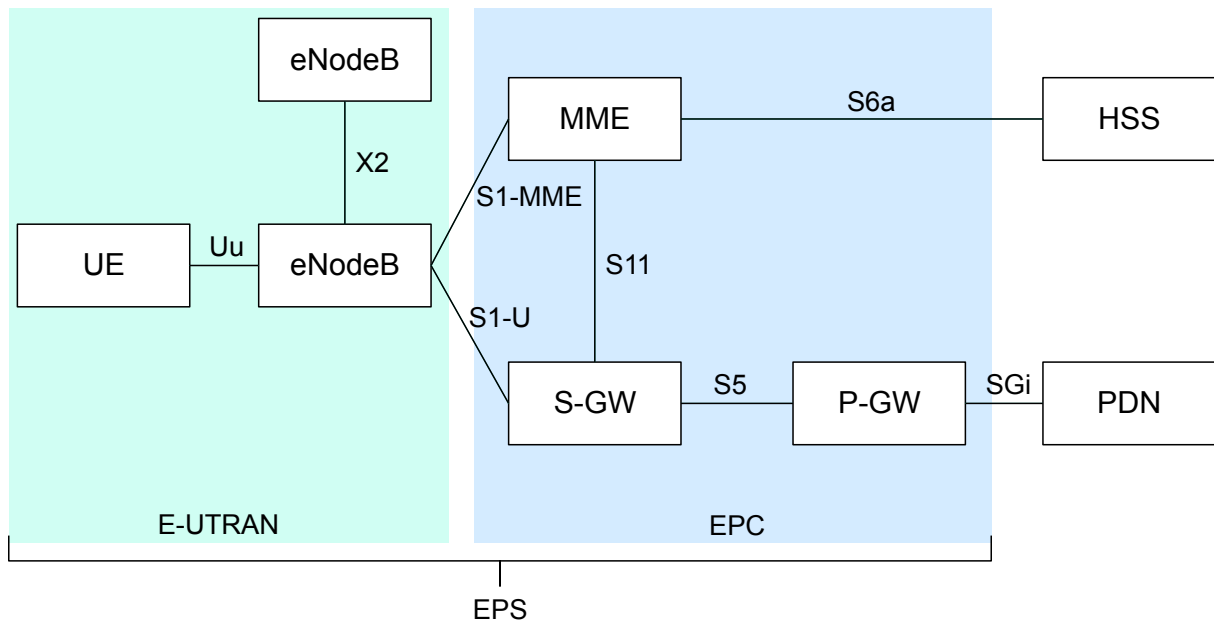

Figure 3.3: EPS elements and interfaces.

The P-GW provides user plane connectivity between UE, S-GW and P-GW. The P-GW interfaces with S-GW, and with an external packet data network (PDN). Some of key functionalities of P-GW are as follows [51]:

- UE IP address allocation;
- Deep packet inspection, or packet screening;
- Lawful interception;
- Rate enforcement based on access point name aggregate maximum bit-rate;
- Service level charging.

The MME handles the control plane signaling between UE and other network elements such as home subscriber server (HSS). Key MME functions include [51]:

- Non access stratum (NAS) signaling;
- Security of NAS signaling;
- User authentication;
- Authorization;

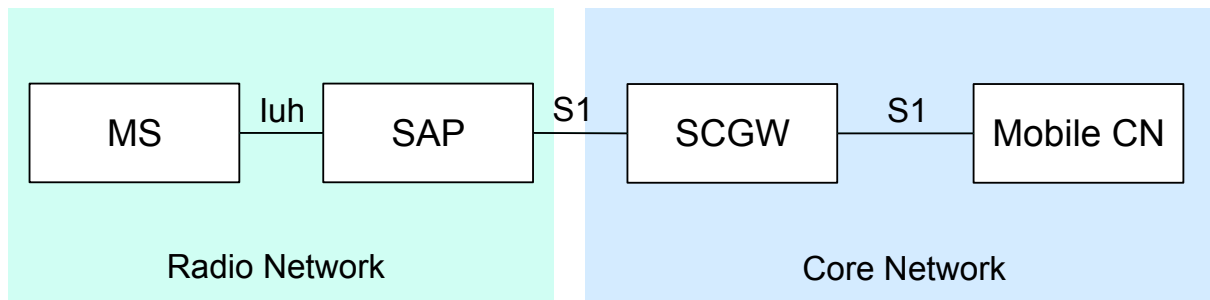

Figure 3.4: SCN architecture [73].

- Establishment and management of bearer;
- MME selection for handovers;
- Selection of P-GW and S-GW elements;
- Lawful interception of signaling traffic.

Small Cell Network Architectural Model

Figure 3.4 shows that small cells can be integrated into the LTE structure with consistency. Here, the functions supported by small cell access points (SAPs) are similar to eNodeBs. Small cell gateway (SCGW) is used to allow the S1 interface between the SAP and EPC, thereby supporting a large number of SAPs. While a SAP appears to the MME as an eNodeB, the former appears to the SAP as the MME. Therefore, a SAP is architecturally indistinguishable from an eNodeB in EPC.

3.2.2 Multi-Operator Networks

In this subsection, I present some multi-operator networks scenarios as shown in Figure. 3.5.

Standalone

In standalone Fig. 3.5 (a), each MNO provides full small cell service to its users for a given coverage area by operating on its own network resources, i.e., spectrum and infrastructures. This model is currently most prevalent in cellular networks where various MNOs have deployed and run their own network in the same region. Considering the rationality and competitiveness among operators, such networks are more likely to be the preferable choice as it encompasses

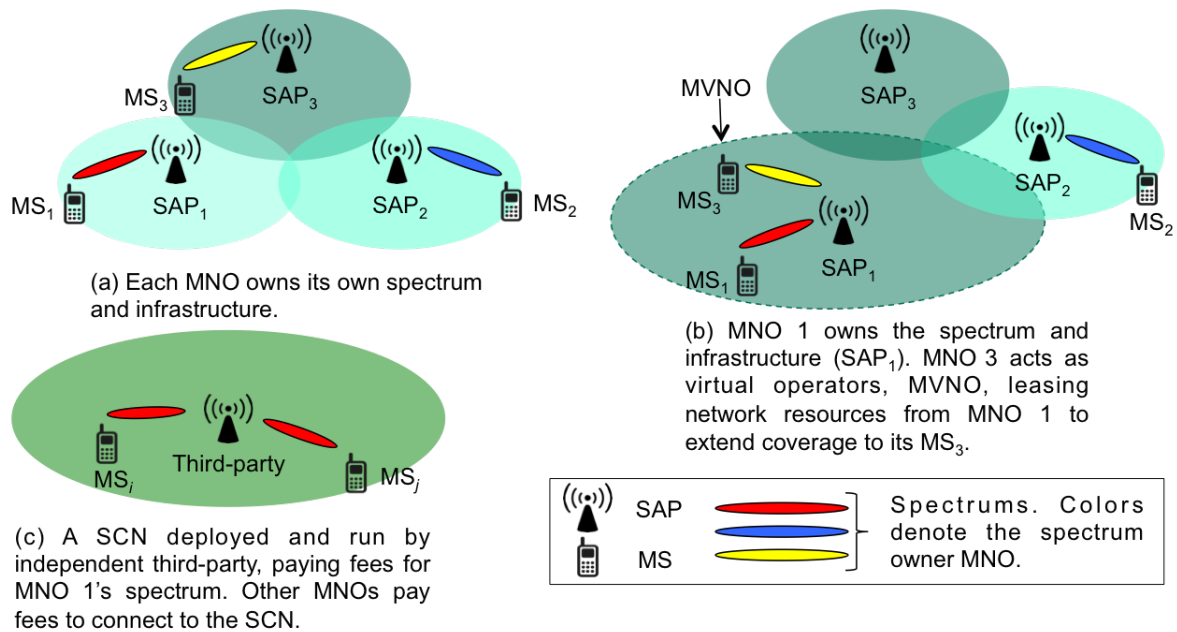

Figure 3.5: Multi-operator networks: (a) *standalone*, (b) *mobile virtual network operators*, and (c) *third-party operator*.

low risk to operators, mainly in dense areas with high traffic where they are able to estimate the expenses of deployment and operation [31]. Although, MNOs have complete control over the resources, they do not have flexibility to benefit from the availability of other MNOs' deployed small cells within the same region such as in situations during varying traffic demands and under-utilization of network resources.

Mobile Virtual Network Operators

In mobile virtual network operators (MVNOs) shown in Figure. 3.5 (b), the spectrum and infrastructure in a given region are owned and deployed by a single MNO, an infrastructure provider (InP). The InP owns radio resources (spectrum) and physical infrastructure while all other MNOs in the region are virtual, hence MVNOs, and since they do not own any spectrum or infrastructure, they rely on leasing for resources in order to serve their subscribers [3]. The existence of MVNOs are beneficial mostly to end-users while the MNO in the area may capitalize their deployed network by using its own subscriber service policy and pricing [74]. The MVNOs utilize the virtual resources from InP depending on specific service level agreements (SLAs) to provide service to their subscribers without knowing the underlying physical network architecture. However, existence and sustainability of such model in the dense network

with small cells are uncertain, as the foreseen traffic demands may not be met only by existing infrastructure and limited resources. Moreover, MNOs are naturally reluctant to share their radio resources with their competitors due to the high spectrum prices [75].

Third-party Operator

A third-party operator, neutral host, in SCNs shown in Figure. 3.5 (c) is defined as “a SCN deployed and run by an independent third party, paying fees for an MNO’s spectrum. MNOs and other providers then pay fees to connect to the network” [66]. In short, neutral host can be used to describe a small cell network operated by a single independent third party where its resources are being shared by multiple MNOs. The main benefit of this model are offloading of the complexities of deployment and management, with lower CAPEX for MNOs, who are not concerned anymore for maintenance of these infrastructures. However, such leasing of the network could induce an increased OPEX in the long run and may not be profitable for the MNOs. Moreover, the possibility of participation of many MNOs in future cellular networks would potentially result to high leasing prices, that might be barriers and challenges for this model.

3.2.3 Multi-Operator based Network Sharing

There are three main approaches to network sharing that can be applicable for SCNs: *multiple operator radio access network* (MORAN), *multiple operator core network* (MOCN), and *gateway core network* (GWCN).

MORAN is a non-3GPP sharing configuration that is widely used in macrocell environment [76], while MOCN and GWCN are 3GPP network sharing configurations [54] as shown in Figure 3.6 [67].

- MORAN shares the backhaul interfaces and BSs only, however the licensed radio resources, radio resource management (RRM) and service configuration are not shared. Hence, it provides some level of independence to each MNO as they continue to use their dedicated spectrum and broadcast their own individual network identifiers.
- In MOCN, all the elements of radio access networks (RANs) including licensed radio resources are shared, except the core networks. Here, the spectrum of multiple MNOs are

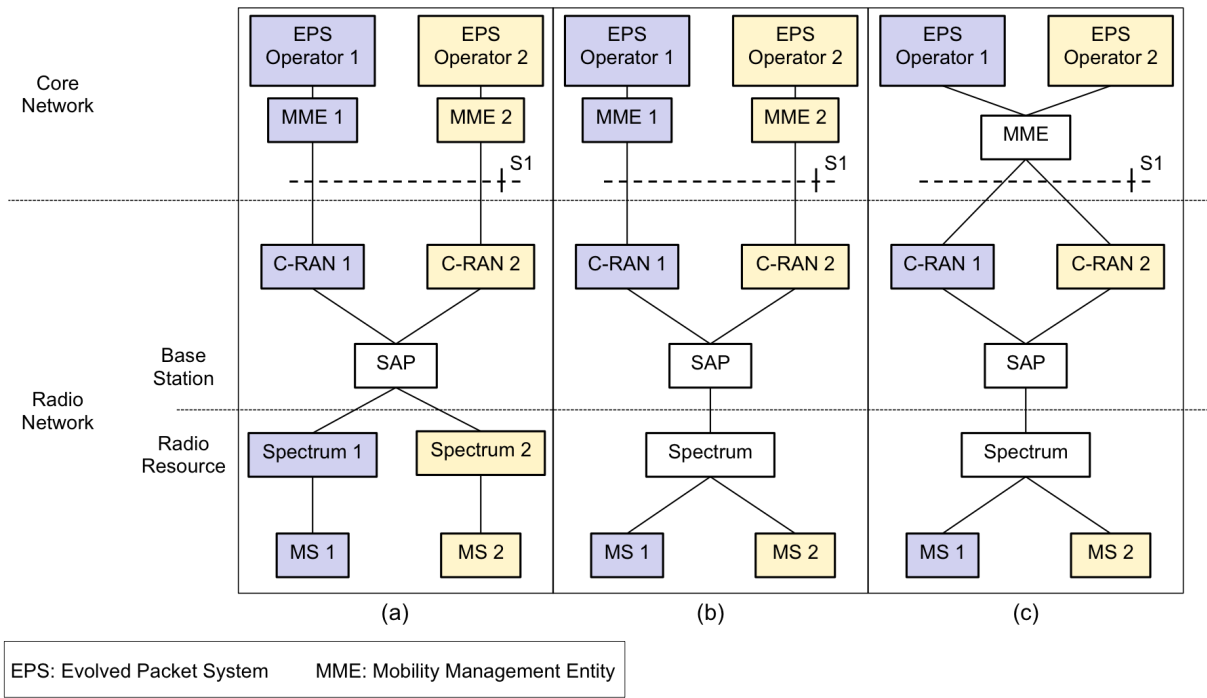

Figure 3.6: Approaches for multi-operator network sharing: (a) MORAN, (b) MOCN, and (c) GWCN.

pooled together into a common spectrum pool.

- The GWCN is an alternative approach to shared network that allows both RAN and core network functions to be shared. In GWCN, inter-networking takes place at the core network level.

3.3 Cooperative and Collaborative Resource Management Framework

In this section, I develop a conceptual framework for resource management in multi-operator based SCNs. Following the proposed framework and its corresponding components, the potential benefits could trigger interest in MNOs to provide multi-operator radio access and allow them to gain an extra share in the network market from their existing network resources (infrastructure and spectrum) and market shares. Here, SCNs of MNOs would evolve to offer small cells “as a service” to meet the expectation of networked society with ubiquitous coverage and services availability. This would also produce an added value to MNOs by retaining

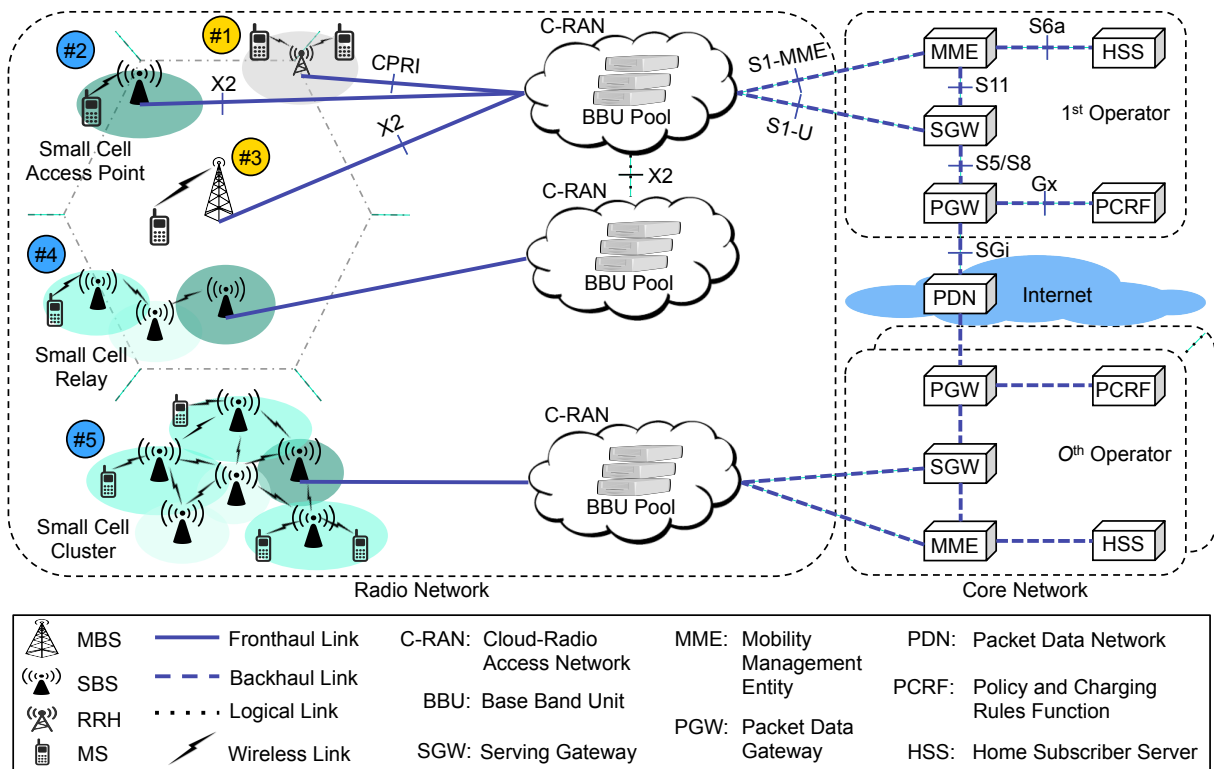

Figure 3.7: A general network architecture of multi-operator small cell networks.

proper network resources utilization by serving subscribers that may belong to several other MNOs and thus attaining improved market share. In this regards, first, I present a model, a general network architecture, for multi-operator based small cell networks. I discuss motivations behind proposing such modified network architecture, backward compatibility to allow for interoperability with previous legacy networks, and several associated benefits that can be achieved by utilizing such network architectural model. Second, I propose the functional architecture of small cell networks that is based on cooperation among several other small cells in the neighborhood. Finally, I present the system architecture of cooperative and collaborative resource management (CCRM) framework, and discuss its several components along with their associated functionality.

3.3.1 Multi-Operator Small Cell Networks: General Network Architecture

Figure. 3.7 depicts a general network architecture of multi-operator SCNs with radio network and core network elements. The core network of a MNO is connected with other MNOs such

that the interconnection of multiple operator's core network is done at core network level. Note that, relevant 3GPP specifications have already added some support for RAN sharing [54, 77]: MOCN and GWCN. MOCN can be viewed as an exclusive enabler for multi-operator small cells support features in Figure. 3.7. Here, the radio elements of MNO are interconnected at a centralized location of the radio network via C-RAN. The C-RAN provides a centralized network view of the underlying radio networks. Such centralized network view with sufficient information of radio resource usage is essential to establish multi-operator small cells support through collaboration for proper network resources utilization in the SCN. The radio networks consist of several technologies interconnected with each other at the C-RAN as shown in Figure. 3.7, such as:

1. *remote radio head,*
2. *small cell access point,*
3. *macrocell base station,*
4. *small cell relay node,* and
5. *small cell cluster.*

In this dissertation, I focus on small cells, however, the work can be applicable with other radio network technologies as well. The infrastructure deployed by a MNO consists of a number of small cells, C-RANs and corresponding core networks elements. The interconnection of the small cells to C-RAN and C-RAN-to-C-RAN is done through X2 interface, while C-RAN to core network is done via S1 interface, delivering both data (e.g., transfer of end users traffic) and control plane functions.

The general network architecture of multi-operator SCNs presented in Figure. 3.7 aims to develop a unified control and coordination framework for multi-operator based radio access networks, in particular enable collaborative control with multiple MNOs to provide efficient radio resource allocation and management in dynamic environment. It provides solution for network-wide coordination and extension of services to users of multiple MNOs. The multi-operator SCNs achieve interconnection among multiple MNOs network and centralized control for network-wide resource coordination via the C-RAN. In C-RAN, I introduce design and development of control mechanism to aggregate abstracted information from the radio network of

a MNO and present collaboration mechanism to be performed among other C-RANs (connected via X2 interface or via the core networks) belonging to multiple MNOs in order to establish efficient radio resource management in such networks of multi-operator SCNs. In reference to such approach, the SCNs evolve to be able to provide multi-operator radio access capabilities, i.e., multi-operator small cells support. In order to do so, MNOs perform execution for collaboration among other MNOs at the C-RAN, which require negotiations on level of service policy to be agreed upon. Upon performing collaboration and reaching agreement to contribute certain level of services, MNOs can provide on demand extensions of services to their subscribers while maintaining an agility to be able to offer new and on-demand service extensions.

3.3.2 Small Cell Networks: Functional Architecture

The SBSs that may belong to several MNOs are usually deployed under the coverage of overlaid macrocell. SBSs under such deployment can exist as a access point, relay node, and in cluster [44]. Figure 3.7 depict different deployment scenarios of SCNs with SBSs underlay within a macrocell coverage. In the scenario, small cells can be standalone and act as access points, where a single small cell could successfully provide service to hot-spots. Meanwhile, in some scenarios, small cells can act as relay nodes to assist other small cells by providing services to users that are not in their coverage range. Moreover, in more general scenario small cells may also be deployed as a cluster to cover some hot-spot areas with high traffic demands over a relatively wide area that are beyond the coverage of a single small cell. It results to a scenario where a blanket of small cells are used to provide coverage to the hot-spot area that are usually beyond the coverage/capacity of a single small cell.

I consider notion of location centric cooperation among small cells of a MNO while network resources allocation. The network resources consist of entities such as radio resources, SBSs and coverage area. In the architecture, I redefine SBSs based on their functions to establish cooperation for proper resource utilization among small cells. The SCN functional architecture for cooperative radio resource allocation to subscribers of a MNO is shown in Figure. 3.8 which consists of SBSs categorized as (i) *small cell point* (SP), (ii) *small cell access point* (SAP), and (iii) *small cell portal point* (SPP).

The basic functions of SBSs as SP, SAP and SPP are described below:

- SP: A SP is the SBS in dormant state, i.e., when there are no MSs associated to it. SP acts

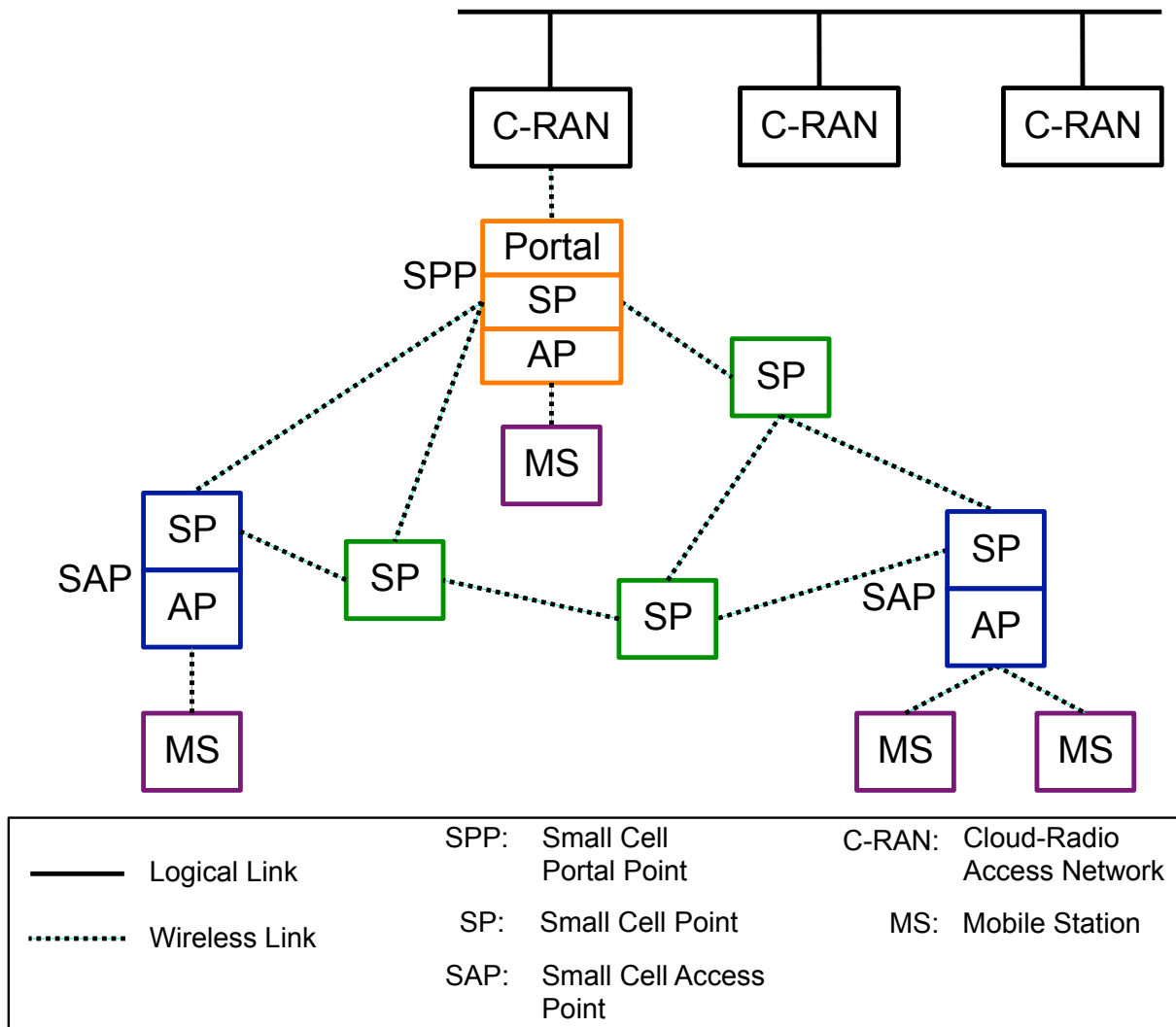

Figure 3.8: A functional architecture of small cell networks.

as a relay node for *information sharing*. All SPs share information, such as channel state information (CSI), over the control channel with neighboring SPs of a MNO.

- SAP: The SAP is a SP acting as a access point to serve MSs, i.e., they provide connectivity. In addition to information sharing, SAP also performs *resource management* that includes *coverage* and *radio resources*.
- SPP: The SPP is a SP acting as a logical point that connects to C-RAN via X2 interface [78]. Typically, I consider at least one SPP per cluster per MNO, ideally those with strong signal strength.

Information Sharing and Coordination Mechanism

The provision of information sharing via SPs has potential benefits in allowing SAPs to take account of radio resource conditions at nearby SAPs when considering for radio resources allocation to its MSs. The information exchange between SAP-SP can provide small cells in the cluster with complete information of its neighborhood environment. SPs can relay information to other SAPs that are not visible to each other. Such an information sharing and coordination mechanism would enable distributed resource allocation feasible, allowing SAPs to self organize by learning their dynamic environment, and gradually allocate their radio resources to their prospective MSs.

3.3.3 Cooperative and Collaborative Resource Management: System Architecture

In this subsection, I briefly discuss operations performed by several modules in the CCRM framework to enable cooperation (for radio resource allocation by SAPs of a MNO) and collaboration (for multi-operator small cells support) based resource management in multi-operator SCNs. In general, the CCRM framework consists of MSs, SAPs, C-RANs and core networks, as shown in Figure 3.9. The CCRM framework enables interconnection between MNOs and intra-connection among SAPs (that may be in isolation or in cluster) belonging to a MNO. Based on the CCRM framework, MNOs could provide an on-demand multi-operator support and sustain network coverage and service availability to their users.

In traditional LTE architecture, radio and baseband processing functionality is integrated inside a BS. C-RAN is a network architecture where baseband resources are pooled, so that they can be processed and managed to be shared between BSs of a MNO [32, 33]. Moreover, C-RAN support different network architecture functional splits, as well as including different levels of functionality implementation. C-RAN of the CCRM framework consists of baseband unit (BBU) where three modules are present, namely: *collaboration management module* (CMM), *operation administration and management* (OAM), and *control and coordination* (CC). Driven by needs for coordination as well as increasing radio resource efficiency, the implementation of these modules in C-RAN allows for processing capabilities such that collaboration between multi-operator could also be established in SCNs.

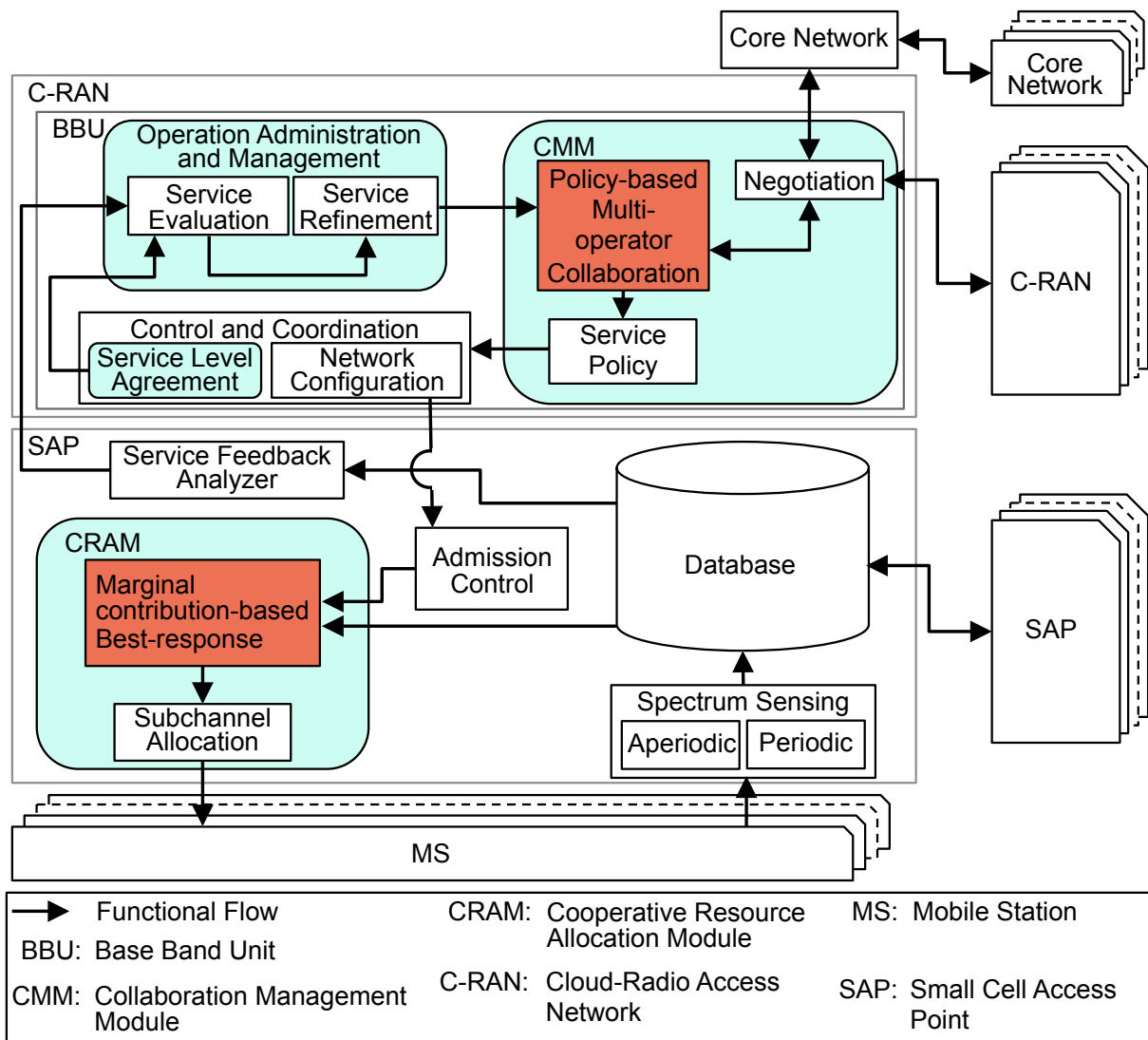

Figure 3.9: A system architecture of CCRM.

The functions of several C-RAN modules in the CCRM framework are briefly described below.

1. Collaboration management module: The CMM is a logical module in C-RAN responsible for establishing collaboration between MNOs. There are three main elements in CMM: (i) *policy-based multi-operator collaboration* (PMOC), (ii) *negotiation*, and (iii) *service policy*. The policy profile of a MNO is dependent on its network resources availability and their utilization. A MNO determines its policy profile to be either a *seeker*, a recipient of service access for some of its users from network resources of other MNOs, or a *feeder*, a provider of service access to some users of the seeker MNO. In this regards, the seeker MNO seeks to sustain coverage and services availability its users, while the feeder MNO

looks forward to gain an extra share in the network market from their existing network resources (infrastructure and spectrum) and market shares. Through negotiation, a seeker MNO and a feeder MNO tries to establish mutual agreement acceptable to both that would provide them with collaboration gains. Upon collaboration agreement, MNOs configures their radio network according to the service policy that consists of: (i) agreement price for desired level of service to be paid by the seeker MNO, and (ii) number of MSs of the seeker to be served by the feeder MNO.

The details of CMM operation are further discussed in Chapter 5.

2. Operation administration and management: The OAM is a logical module present in C-RAN that basically performs monitoring and configuration of services to be established among multiple MNOs. It is in charge of network-wide service evaluation as well as additional refinement of the existing services and/or new requirement services. The analyzed service feedback information from the network-edge based SAPs are feed into the OAM of a C-RAN, which evaluates essential requirements for proper sustainability and operation of the MNO's radio network. The OAM acts as a centralized point for service evaluation of the aggregated service information from several locally deployed SAPs of a MNO. The evaluation includes monitoring of services provided from SAPs of a MNO, and then to refine necessary requirements to ensure that provision of desired level of service from the MNO can be sustained. The aim pursued upon service evaluation may be the desire to optimize the operation of the network resources utilization from a perspective purely based on objective parameters. It indicates the service qualities provided by the provider (MNO) that are expressed in terms of parameters such as delay, average data rate, packet loss rate, etc. Basically, it determines whether services provided to MSs, associated with SAPs of a MNO, are meet or not by utilizing their network resources. The necessary additional requirement to maintain desired level of service are feed to CMM, such that extension of services to the subscribers can be delivered by establishing collaboration among other MNOs.
3. Control and coordination: The CC performs control and coordination operations, based on centralized network view, on service policy decisions from the CMM and sends the decision to SAPs for execution. It is used both for setup of new bearer and for handover candidate MSs to SAPs. First, it performs network configuration and sends the service

policy decision to SAPs for its execution. While the service level agreement keeps record of the service policy decision and also forwards it to the OAM for service evaluation process, i.e., to evaluate the collaborating MNOs commitment towards the service policy decisions by comparing service feedback information to the service agreement.

While in a SAP, several elements maintain flow of information to C-RAN and functions for provision of network resources to MSs. The primary task of a SAP is to perform network resource allocation to the MSs associated to them. Moreover, apart from the legacy functions of SAP, it also performs other crucial tasks such as necessary information exchange among other SAPs in the neighborhood and feedback achieved service to the C-RAN for service evaluation process following the system architecture of CCRM in Figure. 3.9. The functions of several elements of SAP are briefly described below.

1. Cooperative resource allocation module (CRAM): The CRAM in a SAP provides distributed resource allocation to its MSs. Based on the information from MSs and other SAPs, it allocates the radio resources to its MSs such that the overall system capacity of the SCN is maximized. There are two main elements in CRAM: (i) *marginal-contribution-based best-response* (MCBR), and (ii) *subchannel allocation*. The resource allocation for MSs associated to the SAP is performed by utilizing MCBR. After processing MCBR, radio resources (subchannels) are allocated to respective MSs for data transmissions. The MSs operate on this subchannel until the next subchannel allocation update session, and also feedback their achieved data rates (service quality) on the allocated subchannel back to the SAP during spectrum sensing. The details of CRAM operation are further discussed in chapter 4.
2. Spectrum sensing, and database: The SAP performs spectrum sensing, either aperiodic or periodic, for the allocated subchannel to the associated MSs. The necessary information channel condition information parameters, such as SINRs, data rates, etc., are then stored in the database, and also forwarded to the service feedback analyzer and to neighboring SAPs in order to facilitate them for proper functioning of the CRAM. The SAP interact with neighboring SAPs/SPs on X2 interface for sharing and collecting significant portion of the database information. The CRAM extracts relevant information to them, such as data rates on subchannels achieved by MSs, which are useful and significant information for performing MCBR and subchannel allocation to MSs.

3. Service feedback analyzer: It analyses the service provisioned by the SAP to the associated MSs while utilizing the network resources of a MNO. It extracts and examines aggregated information in the database such as service (data rates) achieved by MSs while allocated to a subchannel by MCBR. The analysis indicates how well a SAP sustains desired level of service provision to MSs. The analyzed service feedback information from MSs are further forwarded to service evaluation in the OAM module in the C-RAN, which evaluates essential requirements for proper sustainability and operation of the MNOs radio network.
4. Admission control (AC): The main task of AC is to admit or reject admission requests of MSs to the SAP for resource allocation. AC is performed on MSs for service access from the SAP. The AC ensures high radio resource utilization (by accepting new MSs requests as long as radio resources are available) and at the same time ensure proper service provision for in-progress sessions (by rejecting new MS requests and/or terminating MS admission when they cannot be accommodated). It also receives network configuration information based on service policy from the CC module in C-RAN to grant SAP's admission to MSs that belong to other MNOs.

3.4 Summary

In this chapter, I introduced architecture for multi-operator SCNs, such that the legacy SCNs architecture is evolved to provide multi-operator small cells support for radio access capabilities to the subscribers of the collaborating MNOs, and deliver ubiquitous coverage and services availability in the wireless cellular networks. The introduced concept of collaboration among multiple MNOs provides them with collaboration gains, through mutual agreement acceptable to both, and this motivates them to utilize their exclusively owned network resources to serve others' subscribers. The multi-operator small cells support provides an extension of services to the network users irrespective of their subscription to a MNO, and would contribute to meet the expectation of a networked society for the 5G and future networks.

Chapter 4

Cooperative Resource Allocation Management and Control

4.1 Introduction

Small cells, which are typically characterized as providing dynamic range coverage and low-powered radio access nodes overlaid on macrocells, provide more flexible and scalable deployment by reusing available radio resources [79]. Deployment of small cells decreases the load of MBSs, provides a better link with a reduced distance between serving BSs and MSs, and enhances network performance with improved capacity. However, the advantages of small cells could be insufficient in dense and random networks due to strong co-channel interference from neighboring small cells utilizing common radio resources, such as subchannels in OFDMA-based networks [12]. Resource allocation becomes a critical issue and a challenge as it induces interference in the network, restricting both capacity and cellular coverage [3].

In this chapter, I focus on coordinated learning rules for resource allocation and model OFDMA-based SCNs consisting of SAPs as distributed decision-makers trying to select a proper subchannel for transmission. In this regards, the objective is to find a distributed solution that maximizes the welfare of the SCNs, defined as the total system capacity. First, I study the performance of BR dynamics [80] for the problem of subchannel allocation in OFDMA-based SCNs consisting of SAPs that act as non-cooperative and cooperative decision-makers. The ‘traditional’ BR dynamics require centralized schedulers such that at each time-slot only a single player is chosen to update its strategy, i.e., sequential move [64]. Also, the selected player

could not update its strategy again until all the remaining players have played, which may result in slower rate of convergence [81]. On the other hand, if all players are allowed to switch their strategies at every time-slot (i.e., all players make simultaneous move), an oscillation can occur that would greatly degrade the network performance [64]. To overcome such inherent limitations of BR dynamics, I divide my study into two parts: (i) each SAP is modeled as a non-cooperative decision-maker, and (ii) each SAP is modeled as a cooperative decision-maker. In part (i), I show that stochastic BR dynamics can overcome the requirements of centralized coordination when performing distributed resource allocation. In part (ii), I show that by regulating players to perform coordinated actions while opting to update to their BR strategies could allow multiple players to switch their strategies at each time-slot. Such coordinated actions eventually speed-up convergence to a steady-state in cooperative SCNs. Although the proposed schemes address the limitations of the traditional BR dynamics, such a greedy adaption-based resource allocation, in general, does not necessarily result in a steady-state solution.

To guarantee for existence of a steady-state solution, finally I resort to a class of potential game called the exact potential game [65], and utilize the concept of marginal contribution [36] as a mechanism to design the welfare-based learning rule to achieve efficient resource allocations. However, the performance guarantee of EPGs comes at the expense of complete information of the environment [36], i.e., decision-makers usually require overall information from other remaining decision-makers in the network [82, 83], making the solution unscalable. To overcome the requirement of global information, I propose the marginal contribution based best-response (MCBR) algorithm of low computational complexity by modeling information exchange requirements only on a specific subchannel of the neighborhood. Finally, I validate and evaluate the proposed schemes through simulations for various performance metrics.

4.2 State-of-the-Art for Resource Allocation Management

Centralized approaches for resource allocation [84–87] require some central authority to maintain complete knowledge of the environment through frequent information exchange with SAPs. However, such requirements may not be desirable when considering randomly deployed large numbers of small cells, due to the computational complexity of the centralized solution [36]. As the number and location of small cells become unpredictable, mobile operators should consider distributed approaches allowing SAPs to self-organize by learning their dynamic environment,

and gradually allocate resources.

Game theory [60], as a distributed approach for resource allocation, is suitable for modeling the individualistic behaviors of small cells, where interactions among multiple decision-makers (players) over common resources can be formulated and analyzed as a game. Recently, researchers have proposed distributed learning rules for the problem of resource allocation [81, 88–93], which can be generalized in two ways: (1) as uncoordinated; and (2) as coordinated. Some uncoordinated learning rules, such as spatial adaptive play [88], utility-based learning [89], stochastic-learning-automata [90], and reinforcement learning [91], are completely uncoupled, i.e., the resource allocation procedure does not depend on the actions of anyone else. With restriction to information exchange, the achieved solutions of these approaches have a trade-off in terms of convergence speed and efficiency. Coordinated learning rules, for example, cloud-assisted best-response [81] and cluster formation [92, 93], require some coordination mechanism such that a player is selected to opportunistically update its strategy at a given time. Although it maintains fairness by providing equal opportunity to the decision-makers, such a greedy adaption-based resource allocation, in general, does not necessarily result in a steady-state solution. Nevertheless, the distributed approaches have the advantages of scalable implementation, but their performance is typically inferior compared to the centralized approaches. In this regard, while distributed decision-makers are opportunistically trying to maximize their own performance, it is necessary to implement some mechanisms in their learning rules such that stable resource allocation can be obtained, while efficiency and fairness are also maintained within the network.

The main contributions in this chapter are summarized as below:

- For the objective of finding distributed subchannel allocation in SCNs, the concept of MC is utilized to design a welfare-based learning rule for the decision-makers. It is shown that efficient subchannel allocation is achievable in a distributed network if some sort of self-awareness is introduced to decision-makers' learning rules, such that each decision-maker will adapt to improve some measure of the influence caused by its actions to others in the network in addition to improving its own performance.
- The welfare-based learning rule maintains the universal properties of an EPG; hence convergence to a pure strategy NE is predictive and guaranteed through BR dynamics. Moreover, the proposed MCBR algorithm overcomes the short-comings of EPG for practical

implementations in the distributed networks, i.e., complete information of the environment. Here, a decision-maker utilizes the concept of probability distribution in order to select a new subchannel for sensing, and requires information feedback only from those neighboring decision-makers currently using the subchannel.

The wireless cellular networks have witnessed an exponential growth in mobile data traffic, mainly due to the popularity of multimedia services and high data rate applications [1]. One of the key emerging trend to accommodate such demand is through network densification, such as extensive deployment of SBSs, by reusing radio resources [11]. Network densification with small cells, which results in spatial densification, has attracted much attention [94–96] due to its promising network performance with improvement in capacity. Several studies have provided prospects on it from the perspective of key challenges [3, 96, 97], identifying interference management and resource allocation as the most crucial issues that can limit the gains anticipated.

The centralized approaches [84–87] for solving the resource allocation problem in random and dense SCNs are not scalable due to the requirement of global information to manage the whole network. On the contrary, convergence speeds of the distributed approaches that require no information exchange [88–91] are very slow, giving rise to the inherent limitations for practical implementation in large-scale networks with extensive deployment of SBSs.

In this work, unlike the traditional opportunistic learning rules in most of the previous studies [81, 92, 93] where each decision-maker acts rationally to maximize their individual performance, I show that implementing the proposed mechanism of the welfare-based learning rule for decision-makers provides network-wide performance improvement with considerate fair and stable resource allocation solution. Moreover, it is suitable for practical implementation as it requires only local and limited information exchange, which results in low computational complexity.

Recently, the concept of network sharing has also been investigated to allow operators to share their infrastructures in order to maximize the use of existing radio resources while simultaneously minimizing the operational costs [31, 54, 66, 98, 99]. The works in this chapter facilitates these recent trends and can be applied as a tool to achieve the much anticipated gains through deployment of small cells by efficient allocation of the radio resources in a distributed fashion. Also note that, the proposed distributed subchannel allocation scheme can also be applied to wireless sensor networks (WSNs) to assist resource-constrained sensors in realizing

efficient utilization of the spectrum.

4.3 Best-Response Strategy for Distributed Subchannel Allocation

In this section, I study the BR strategy for games, cooperative and non-cooperative, for the subchannel allocation problem. I model the problem as a multi-agent game, where each player repeatedly best-responds to the others' actions [80]. The OFDMA-based SCNs consists of SAPs that act either as non-cooperative or cooperative decision-makers for distributed subchannel allocation. I focus on BR dynamics [80] based learning rule, which is natural and simple behavior to build into distributed systems [100]. Under the "traditional" BR dynamics, players are restricted to take turns while selecting strategies, each repeatedly selecting a pure strategy that maximizes its utility given others' current strategies. This goes on until a steady-state, i.e., a pure strategy Nash equilibrium, is reached [80]. However, this requires centralized schedulers such that at each time-slot only a single player is chosen to update its strategy, i.e., sequential move [101]. Also, the selected player could not update its strategy again until all the remaining players have played, which may result in slower rate of convergence [81]. On the other hand, if all players are allowed to switch their strategies at every time-slot (i.e., all players make simultaneous move), an oscillation can occur that would greatly degrade the network performance [101]. To overcome such inherent limitations of BR dynamics, I divide my study into two parts: (i) each SAP is modeled as a non-cooperative decision-maker, and (ii) each SAP is modeled as a cooperative decision-maker.

In part (i), I focus to overcome the requirement of centralized coordination in BR strategy, and propose stochastic best-response-based distributed subchannel selection (SBDSS) algorithm. Here, players best-respond with an uncertainty of strategy updates at each time-slot, which is dependent on some probability p . The randomness ($0 < p < 1$) allows us to perform uncoordinated sequential updates without the requirement of any centralized scheduler, and also avoids simultaneous moves that would have resulted with an oscillation among some set of strategy profiles.

In part (ii), I look to speed-up the convergence by allowing multiple players to take simultaneous actions, and hence overcome the requirement of sequential updates in the traditional BR

strategy. Here, I assume that the actions of each SAP are coordinated among all other SAPs (those with the same BR subchannel), where only the SAP with highest utility switches to the particular subchannel. I propose cooperative best-response-based distributed subchannel selection (CBDSS) algorithm, where with the provision of information exchange among SAPs, the total number of SAPs who simultaneously switches to their BR subchannel at each time-slot is increased to at most the number of available subchannels. Such coordinated actions would eventually speed-up the convergence process.

4.3.1 Non-Cooperative Best-Response for Distributed Subchannel Allocation

In this subsection, I propose distributed subchannel allocation algorithms used by each SAP to attempt to solve the subchannel allocation problem in SCN. To reduce overheads and allow for non-cooperative behaviors, I assume that SAPs do not exchange information about subchannel allocation. However, each SAP can sense and adapt to its environmental changes by selecting a proper subchannel allocation. Provided with such sensing capabilities, each SAP can make its own decision of transmission on subchannel that will give them a better SINR.

The distributed algorithm shown in Algorithm 1 is based on a game approach, following the concept of the BR strategy (see, e.g., [80, 101, 102]), where each player selects the best action that maximizes its own utility given the current strategies of all other players.

Specifically, I assume that all SAPs are synchronized and the time is divided into time-slots of a fixed duration. Each time-slot is further divided into two time duration or phases, called **sensing** phase and **payload** phase. During the sensing phase of time-slot t , each SAP senses the subchannels for their SINRs on link i . During this sensing phase, all SAPs keep transmitting at their selected subchannels used in the previous time-slot $t - 1$.

After getting the SINR measurement on all the subchannels, at the end of the sensing phase each SAP selects the subchannel with the highest SINR for transmission in the payload phase (the rest of time-slot t). By selecting the highest SINR subchannel, each SAP attempts to maximize its own subchannel capacity for link i given the strategies or actions of other links in the previous time-slot and assuming that other players will not change their selections at the next time-slot. This is a version of the *deterministic* BR strategy.

In the next time-slot $t + 1$, each SAP for link i senses the SINR of all subchannels again

Algorithm 1 BR strategy for each link i

01 : **Initialization phase:**

02 : Get synchronization.

03 : Select a subchannel k_0 randomly from set \mathcal{K} .

04 : Transmit during the sensing phase on subchannel k_0 .

05 : **Sensing phase** of time-slot $t = 1, 2, \dots$:

06 : Measure SINR, $\gamma_{i,k}$, of each subchannel $k \in \mathcal{K}$.

07 : Select the BR subchannel, k' , with highest-SINR

08 : **Payload phase** of time-slot t :

09 : Transmit on subchannel k'

10 : Set $t \leftarrow t + 1$. Go to Step 05.

during the sensing phase and chooses the subchannel with the highest-SINR for transmission in the payload phase for that time-slot $t + 1$. This process is repeated forever and we have a repeated BR strategy [80]. For example, if link i uses subchannel $k_{i,t}$ during the payload phase of time-slot t , it will still transmit on subchannel $k_{i,t}$ during the sensing phase of time-slot $t + 1$. However, link i may use another subchannel $k'_{i,t+1}$ during the payload phase of time-slot $t + 1$.

Since the subchannel used in payload phase of current time-slot is determined from SINRs resulted from subchannels allocation in previous time-slot and links update their subchannel selection simultaneously (hence, they are making a simultaneous move), there could be oscillations between some sets of strategy profiles.

An Example of Oscillating Behavior

Let us analyze a simple example to gain more understanding of the oscillation problem. Consider an example with only two subchannels and three SAP-MS links. For simplicity, I assume all MSs are co-located, all SAPs are co-located, and the same Gaussian noise levels. Hence, all links are homogeneous, i.e., they have the same received power and the same signal-to-noise ratio (SNR). I call this example a 3-link-2-ch homogeneous case. For this case there are eight possible subchannel allocations: the two *same-channel* allocations for the three links are 111 and 222 and the six *mixed-channel* allocations are 112, 121, 122, 211, 212, and 221.

Regarding the instantaneous total capacity, each same-channel allocation has the same in-

stantaneous total capacity, ideally given by the Shannon's capacity

$$C_0 = 3 \log_2 \left(1 + \frac{P}{2P + N} \right) \text{ bps/Hz} \quad (4.1)$$

where P denotes the received signal power and N the received noise power. In this same-channel allocation, each link receives the same individual capacity. For the mixed-channel allocations, each allocation has the same instantaneous total capacity of

$$C_1 = \log_2 \left(1 + \frac{P}{N} \right) + 2 \log_2 \left(1 + \frac{P}{P + N} \right) \text{ bps/Hz} \quad (4.2)$$

Here the link with the subchannel different from the others has higher capacity of $\log_2 \left(1 + \frac{P}{N} \right)$, while the other two links each has capacity $\log_2 \left(1 + \frac{P}{P+N} \right)$.

Let's now consider two different scenarios that result in oscillation of subchannel allocations:

Scenario 1 : If initially at time-slot $t = 0$, the subchannel allocation is the same-channel, say 111, then during the sensing phase of time-slot $t = 1$ all links would sense that the SINR on subchannel 1 ($\gamma_1 = \frac{P}{2P+N}$) is less than that on subchannel 2 ($\gamma_2 = \frac{P}{N}$), and hence all switch to subchannel 2 during the payload phase of $t = 1$. But in the sensing phase of $t = 2$, they all would sense that $\gamma_1 = \frac{P}{N} > \gamma_2 = \frac{P}{2P+N}$ and all would switch back to subchannel 1. Hence, there is an oscillation between all links using subchannel 1 and subchannel 2. Although the subchannel allocations are alternating between 111 and 222, the instantaneous total capacity in each time-slot is constant at C_0 .

Scenario 2 : If instead, the initial subchannel allocation at $t = 0$ is one of the six mixed-channel, say 112, then at the sensing phase of $t = 1$, all links sense that subchannel 2 has better SINR than subchannel 1. Then, all links would use subchannel 2 during the payload phase of $t = 1$, and then we fall into the oscillation of Scenario 1, i.e., the sequence of subchannel allocations is $112 \rightarrow 222 \rightarrow 111 \rightarrow 222 \rightarrow 111 \rightarrow \dots$

Hence, regardless of initial subchannel allocation, oscillation always occur if each link simultaneously follows the BR strategy in Algorithm 1 due to the simultaneous moves and the fact that each link ignores the possibility that other links might also switch subchannel in the next time-slot.

Mixed Nash Equilibrium and Price of Anarchy

In the example of the 3-link-2-ch homogeneous case, the instantaneous total capacity of the initial mixed-channel allocation is higher than that of the initial same-channel allocation only in the initial time-slot, but the average total capacity over a large number of time-slots in both scenarios is equal to C_0 . For this example, although there is no pure strategy NE, there is a mixed NE [60], where each player randomly but equally chooses between the two subchannels, independent of the sensed SINR. This results in a Markov chain where over the long run, the mixed NE assigns a probability $1/8$ to each of the eight sets of all possible subchannel allocations. The instantaneous total capacity is oscillating between two values: C_1 and C_0 (where C_0 happens 0.25 of the time), giving the average total capacity of the mixed NE as

$$C_{\text{MNE}} = 0.25C_0 + 0.75C_1 \quad (4.3)$$

This capacity is between the worst capacity C_0 and the best capacity C_1 , which could occur when the links are assigned the subchannels by a centralized scheduler.

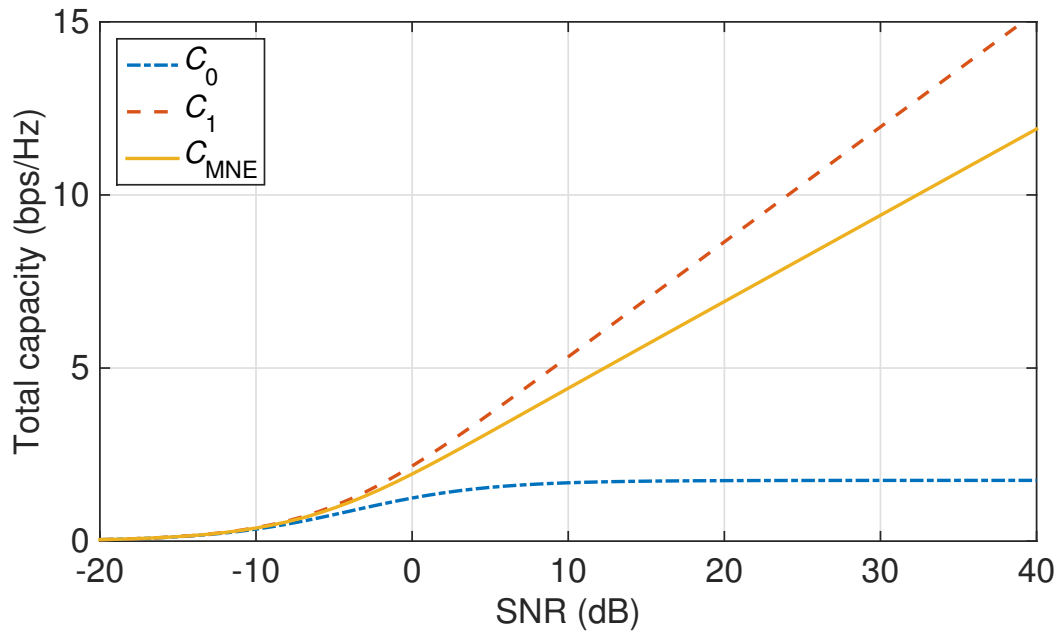

(a)

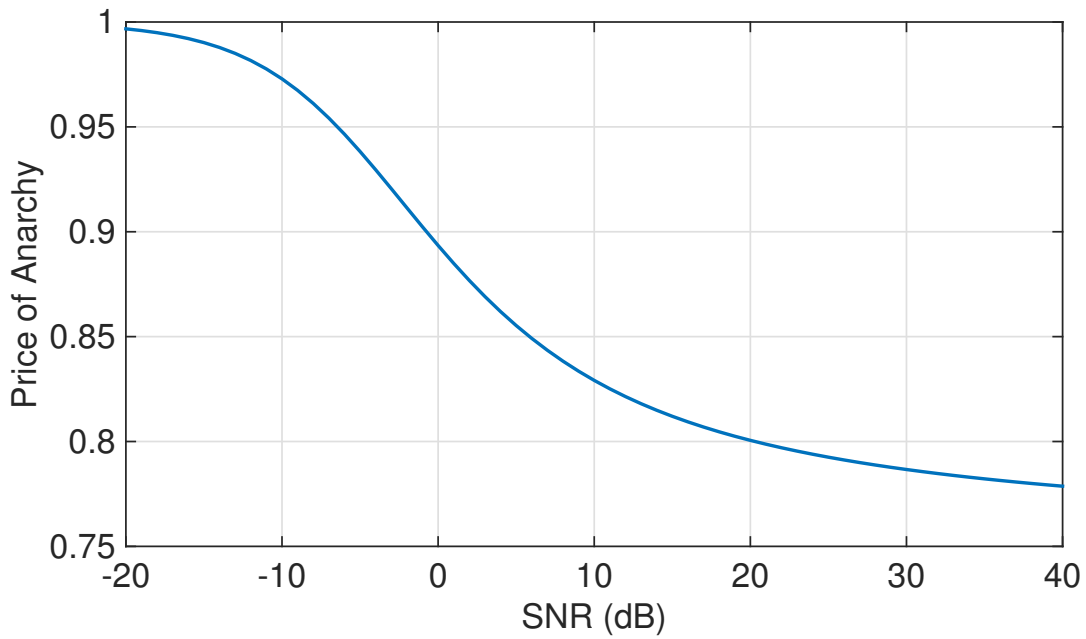

(b)

Figure 4.1: The example of three homogeneous links and two subchannels: (a) the instantaneous total capacities, C_0 and C_1 , and the average total capacity for the mixed NE strategies C_{MNE} for varying SNR, (b) the Price of anarchy.

Figure 4.1(a) plots C_0 , C_1 , and C_{MNE} for varying SNR. It is obvious that the capacity C_{MNE} of the mixed NE strategies is lower than C_1 of the centralized strategy. The lower performance of the mixed NE strategies is due to the selfishness of each SAP or the BR strategy. In game theory, one way to measure the efficiency of NE is via the (mixed) *price of anarchy* (PoA), which is the ratio between the performance of the worst mixed NE to that of the optimal centralized strategy [103]. In this example, there is only one mixed NE and the PoA is

$$PoA = \frac{C_{\text{MNE}}}{C_1} = 0.25 \frac{C_0}{C_1} + 0.75 \quad (4.4)$$

as shown in Figure 4.1(b). Note that as $SNR = P/N \rightarrow \infty$, I have $C_1 \rightarrow \infty$ and $PoA \rightarrow 0.75$ since C_0 becomes a constant at high SNR (i.e., $C_0 \rightarrow 3 \log_2(1 + P/2P) = 1.755$ bps/Hz). Hence, the minimum PoA is 0.75.

Avoiding Oscillation Using Stochastic Best-Response

One way to avoid the oscillation problem is avoiding the simultaneous move. This could be done by a sequential move where each link updates its subchannel allocation one at a time in a round-robin fashion, i.e., the sequence of updates is link 1, link 2, link 3, and then link 1 again. Hence, the same-channel allocation is always avoided and the average total capacity is C_1 which is the maximum. However, this would require centralized schedulers such that at each time-slot only a link is chosen to update its subchannel allocation.

To keep our proposed algorithm distributed, I instead avoid the simultaneous moves by having each player updates its subchannel allocation decision independently, without coordination, with a probability p . Hence, Algorithm 1 is revised to be Algorithm 2 (SBDSS algorithm), with the addition of some steps. In Algorithm 2, the new subchannel with the highest-SINR is selected with probability p , otherwise the previous subchannel is used again. I call this revised BR strategy as *stochastic BR*.

This stochastic BR is a version of a round-robin play but with uncertainty of updates or outcomes [104]. Here, I assume that each player plays the BR strategy with probability p if the current strategy is not a BR one. However, if it is already a BR strategy then stay with it. Hence, the deterministic BR strategy is played stochastically.

Algorithm 2 SBDSS for each link i

01 : **Initialization phase:**

02 : Get synchronization.

03 : Select a subchannel k_0 randomly from set \mathcal{K} .

04 : Transmit during the sensing phase on subchannel k_0 .

05 : **Sensing phase** of time-slot $t = 1, 2, \dots$:

06 : Measure SINR, $\gamma_{i,k}$, of each subchannel $k \in \mathcal{K}$.

07 : Select the BR subchannel, k'_t , with highest-SINR

08 : Draw a uniform $[0, 1]$ random variable u .

09 : **If** $u \leq p$

10 : Switch $k_{i,t} = k'$

11 : **Else**

12 : Stay in the previous subchannel, $k_{i,t} = k_{t-1}$.

13 : **Payload phase** of time-slot t :

14 : Transmit on subchannel $k_{i,t}$

15 : Set $t \leftarrow t + 1$. Go to Step 05.

Modeling Stochastic Best-Response as a Markov Chain

The behavior of the stochastic BR can be analyzed using a Markov chain, where the states are the eight different subchannel allocations in $\mathcal{S} = \{111, 112, \dots, 222\}$. It is a Markov chain because the future state at time-slot $t + 1$ depends only on the current state at time-slot t . With the probability p , all transition probabilities can be determined.

Example 4.1: If the current state is 111, then using deterministic BR the new state should be 222, i.e., every player wants to switch to subchannel 2. However, recall that each can only make a switch with probability p . Suppose all players can make the switch, i.e., each can draw $u \leq p$ in Algorithm 2. This happens with probability p^3 . Hence, the transition probability from state 111 to state 222 is

$$P_{(111) \rightarrow (222)} = p^3.$$

However, if only players 1 and 3 get draws less than p while player 2 cannot, the new state is 212 and happens with probability $p \times q \times p$ where $q = 1 - p$ is the probability of not success in switching. Hence,

$$P_{(111) \rightarrow (212)} = p^2 q.$$

Example 4.2: If the current state is 212, then from the deterministic BR the new state should be 111, i.e., only players 1 and 3 want to switch to subchannel 1. However, suppose only player 1 succeeds in switching, the new state is instead 112 and happens with probability $p \times 1 \times q$, where the probability for player 2 to use subchannel 1 is 1 since it always uses subchannel 1 independent of the outcome of the draw in Algorithm 2. Hence,

$$P_{(212) \rightarrow (112)} = pq.$$

A similar reasoning gives $P_{(212) \rightarrow (111)} = p^2$. Note that, since player 2's BR is to stay with subchannel 1, the probability of it moving to subchannel 2 in the next state is 0, i.e.,

$$P_{(212) \rightarrow (i2j)} = 0$$

for any $i, j = 1, 2$.

Other transition probabilities can be calculated similarly. A part of the resulted Markov chain is shown in Figure 4.2 for illustration.

Analysis of the Average Total Capacity

For $0 < p < 1$, the Markov chain is recurrent and aperiodic, and hence ergodic. Hence, in the long run the stochastic BR reaches a steady-state distribution, independent of the initial state. The steady-state probability distribution, $\pi = [\pi_1, \pi_2, \dots, \pi_8]$ where states 111, 112, \dots , 222 are now called states 1, 2, \dots , 8, respectively, must satisfy $\pi = \pi Q$ and $\sum_{i=1}^8 \pi_i = 1$ where $Q = [P_{i \rightarrow j}]$ is the transition probability matrix and $P_{i \rightarrow j}$ is the transition probability from state i to state j for $i, j = 1, 2, \dots, 8$.

Since the Markov chain is ergodic, the average total capacity over the long run for the switching probability p is equal to the average capacity calculated with the steady-state probabilities π , as

$$C_p = \sum_{i=1}^S C_i \pi_i \quad (4.5)$$

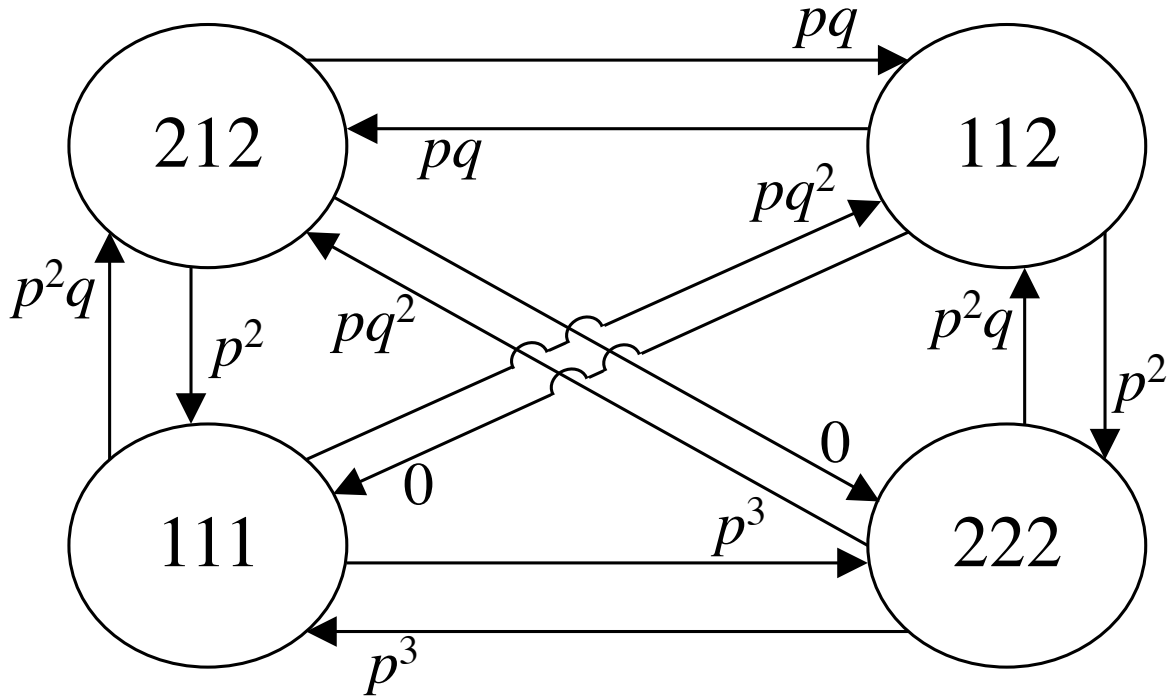

Figure 4.2: Illustration of a part of the Markov chain.

where $C_i = C_0$ for $i = 1, 8$ and $C_i = C_1$ otherwise. The steady-state probability vector π is a function of p . Figure 4.3 plots the average total capacity as a function of switching probability p , where C_p is decreasing with p . As seen in the figure, if switching probability is small, $p < p'$, then the average total capacity can be improved from that of the mixed NE, i.e., $C_p > C_{\text{MNE}}$. However, small switching probability would restrict the links from switching to the BR subchannels most of the time and this may result in slow convergence.

4.3.2 Cooperative Best-Response for Distributed Subchannel Allocation

Despite having advantage of no information exchange and coordination requirement among players, stochastic BR with small value of p still limits the number of players actually updating their strategies at a given time and this may result in slow convergence. Also, in traditional BR dynamics, only one player is selected to update its strategy at a time, i.e., sequential move. Here, players are required to take turns to update strategies for selecting a subchannel that maximizes their utility. Moreover, the selected player may not always update its subchannel, for example if it is already allocated to the BR subchannel. Such underlying requirement of traditional BR would result in a slow convergence to a pure strategy NE, especially in dense network with large

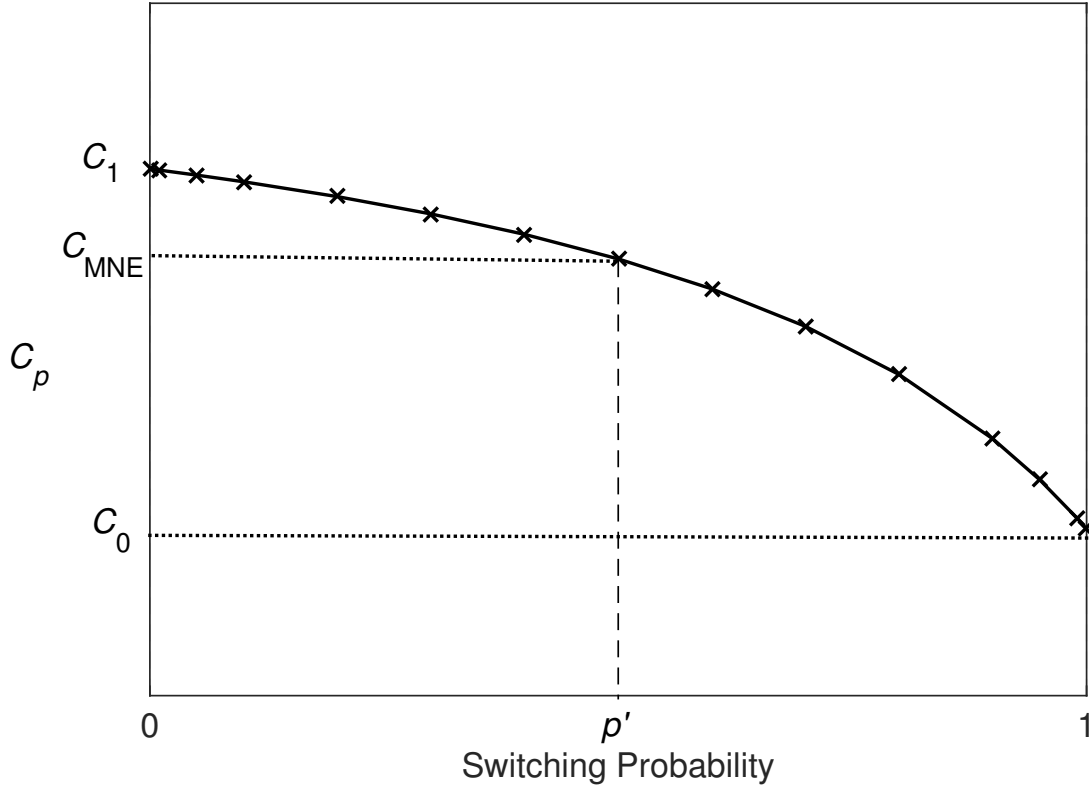

Figure 4.3: Average total capacity as a function of switching probability.

number of links.

To overcome such limitations, I revise Algorithm 1 to Algorithm 3 (CBDSS algorithm) with modification in the utility function and coordination requirements among players while switching to a strategy. Here, I still consider players simultaneously receive an opportunity to switch strategies. However at the time of switching, each player takes coordinated action, such that, it chooses the BR strategy and switch to this strategy if and only if its utility is highest among all other players' utility who are also opting to switch to that strategy. Otherwise, the player stays at its current strategy.

Specifically during the sensing phase of time-slot t , each link $i \in \mathcal{M}$ computes SINR measurement on all subchannels and selects the BR subchannel k' with highest-SINR. Now, the utility for link i is defined as the SINR improvement on the BR subchannel k' as compared to the previous subchannel k_{t-1} , denoted as $\Delta\gamma_{i,k'}$, such that,

$$\Delta\gamma_{i,k'} = \gamma_{i,k'} - \gamma_{i,k_{t-1}} \quad (4.6)$$

Finally, the decision to switch to the BR subchannel k' by link i is coordinated among all other links j also having the same BR subchannel, which is given as

$$k_{i,t} = \begin{cases} k'; & \text{if } \Delta\gamma_{i,k'} > \Delta\gamma_{-i,k'} \\ k_{t-1}; & \text{otherwise} \end{cases} \quad (4.7)$$

where, $\Delta\gamma_{-i,k'} = \max_{j \neq i} \Delta\gamma_{j,k'}$ is the highest-SINR improvement among all other links j with the same BR subchannel k' . Here, if link i has the highest-SINR improvement as compared to all other links j who want to use the same BR subchannel k' , then only link i switches to this subchannel, i.e., $k_{i,t} = k'$. Otherwise, link i would stay on its previous subchannel, i.e., $k_{i,t} = k_{t-1}$.

Such a coordinated response to BR subchannels would result in at most K number of links simultaneously switching their subchannels at a given time. However, this requires exchange of utilities information among links having the same BR subchannel. Here, this exchange of information can be done through small cell gateways, direct link between SBSs (similar to the X2 interface in LTE), or broadcast over the control channel.

4.3.3 Computational Complexity Analysis

At each iteration, the sensing phase complexity for SBDSS and CBDSS is $\mathcal{O}(KT)$, which results while sensing all the subchannels, where T is the duration of the sensing phase. While there are no information exchange in SBDSS algorithm, CBDSS algorithm incorporates additional information exchange overhead to compute (4.7). The complexities for information exchange in CBDSS is $\mathcal{O}(|M|)$, the upper bound, and $\Omega(0)$, the lower bound. This range corresponds to the two extreme cases: all other links have the same BR subchannel, and none, respectively.

4.4 Marginal Contribution-Based Distributed Subchannel Allocation

In order to capture benefits associated with an EPG, i.e., to look for existence of steady-state and avoid the oscillations problem in the game, it is desirable to design the utility function for players according to some specified learning rules. This can provide predictive performance

Algorithm 3 CBDSS for each link i

01 : **Initialization phase:**

02 : Get synchronization.

03 : Select a subchannel k_0 randomly from set \mathcal{K} .

04 : Transmit during the sensing phase on subchannel k_0 .

05 : **Sensing phase** of time-slot $t = 1, 2, \dots$:

06 : Measure SINR, $\gamma_{i,k}$, on each subchannel $k \in \mathcal{K}$.

07 : Select the BR subchannel, k' , with highest-SINR

08 : Compute the SINR improvement, $\Delta\gamma_{i,k'} = \gamma_{i,k'} - \gamma_{i,k_{t-1}}$

09 : Update $\Delta\gamma_{i,k'}$ and receive $\Delta\gamma_{j,k'}$ from other links j

10 : **If** $\Delta\gamma_{i,k'} > \Delta\gamma_{-i,k'}$

 Switch $k_{i,t} = k'$

Else

 Stay on the previous subchannel, $k_{i,t} = k_{t-1}$

11 : **Payload phase** of time-slot t :

12 : Transmit on subchannel $k_{i,t}$

13 : Set $t \leftarrow t + 1$. Go to Step 05.

in the subchannel allocation game when players rationally play according to BR dynamics. Desirably, to optimize the total capacity of the SCN while players distributively chooses their strategies, a simple and straightforward option would be to assign the players' utility function and potential function equal to the total capacity (similar to the identical interest games [105, 106]), such that:

$$u_i(s_i, \mathbf{s}_{-i}) = \mathbf{P}(\mathcal{S}) = \mathcal{C} \quad (4.8)$$

However, for the utility function in Equation (4.8), each link i would require information feedback from all other links, which would become extremely complicated in a dense SCN.

4.4.1 Marginal Contribution

Looking forward to reduce the computational complexities while keeping the objective to maximize total capacity of the SCN, I resort to utilizing design rule of utility function based on the concept of MC that is also proven to be an EPG [36]. The concept of MC considers designing

utility function derived directly from the potential function, and is defined as [36],

$$u_i^{\text{MC}}(\mathbf{s}) = \mathbf{P}^{\text{MC}}(\mathbf{s}) - \mathbf{P}^{\text{MC}}(\mathbf{s}_{-i}) \quad (4.9)$$

where $\mathbf{P}^{\text{MC}}(\mathbf{s})$ and $\mathbf{P}^{\text{MC}}(\mathbf{s}_{-i})$ are the value of potential function with presence and absence of player i in the game, respectively.

4.4.2 Utility Function Design with Limited Information Feedback

I consider a potential function, $\mathbf{P}^{\text{MC}} : \mathcal{S} \rightarrow \mathbb{R}$, with the objective to maximize total capacity of the SCN for transmission of link $i \in \mathcal{M}$ on subchannel k , such that,

$$\mathbf{P}^{\text{MC}}(\mathcal{S}) = \sum_k W_k(\mathbf{s}) \quad (4.10)$$

where $W_k(\mathbf{s}) = \sum_{i:s_i=k} \mathcal{C}_{i,k}$ is the total welfare (in term of capacity) from all links that are using subchannel k . Hence, the potential function $\mathbf{P}^{\text{MC}}(\mathcal{S})$ essentially reflects overall capacity in Equation (2.4).

From Equations (4.9) and (4.10), I express the utility of link i when it is using subchannel k' , i.e., $s_i = k'$, while the other links are using strategies \mathbf{s}_{-i} as,

$$\begin{aligned} u_i^{\text{MC}}(s_i = k', \mathbf{s}_{-i}) &= P^{\text{MC}}(s_i = k', \mathbf{s}_{-i}) - P^{\text{MC}}(\mathbf{s}_{-i}) \\ &= \sum_k W_k(\mathbf{s}) - \sum_k W_k(\mathbf{s}_{-i}) \\ &= \left(W_{k'}(\mathbf{s}) + \sum_{k \neq k'} W_k(\mathbf{s}_{-i}) \right) - \left(W_{k'}(\mathbf{s}_{-i}) + \sum_{k \neq k'} W_k(\mathbf{s}_{-i}) \right) \\ &= W_{k'}(s_i, \mathbf{s}_{-i}) - W_{k'}(\mathbf{s}_{-i}) \end{aligned} \quad (4.11)$$

where $W_{k'}(s_i, \mathbf{s}_{-i})$ and $W_{k'}(\mathbf{s}_{-i})$ are the total welfare on subchannel k' with presence and absence of link i in the game, respectively. Here while learning the utility on subchannel k' to improve its own performance, the link i is aware of its influence to other links that are using subchannel k' . From Equation (4.11), since link i is using only subchannel k' , the total welfare on all other subchannels, $k \neq k'$, is the same as that without link i , i.e., I have for any subchannel $k \neq k'$, $W_k(s_i = k', \mathbf{s}_{-i}) = W_k(\mathbf{s}_{-i})$ and hence the total welfare from all other subchannels (except k') is the same with and without link i . With this observation, the utility of link i is expressed simply as $u_i(s_i = k', \mathbf{s}_{-i}) = W_{k'}(s_i, \mathbf{s}_{-i}) - W_{k'}(\mathbf{s}_{-i})$, which is the additional welfare

on subchannel k' when link i is in the game, compared to that when link i is not in the game, assuming all other links stay using the same strategies s_{-i} . Hence, the computational complexities to compute the utility are reduced in this game, since link i would require information feedback only from those links that are also using subchannel k' , i.e., for which the strategy is $s_{-i} = k'$.

The game with utility function in Equation (4.11) is an EPG for the potential function in Equation (4.10) as shown in Theorem 1.

Theorem 1. *The game $\mathcal{G} = (\mathcal{M}, \{\mathcal{S}\}, \{u_i^{\text{MC}}(\mathbf{s})\})$ is an EPG and has at least one pure strategy NE.*

Proof. As shown in Section 3.2.2. of [36], when we set MC as a utility function, the game with this utility function is proven to be an EPG where the strategy profile that maximizes the potential function is the pure strategy NE. \square

Corollary 1.1. *For a particular initial subchannel profile and sequence of play, the pure strategy NE of the game $\mathcal{G} = (\mathcal{M}, \{\mathcal{S}\}, \{u_i^{\text{MC}}(\mathbf{s})\})$ is unique.*

Proof. Consider an initial subchannel profile, $(s_1, \dots, s_i, \dots, s_M)$ where $\forall i \in \mathcal{M}$, and there is a strategy update sequence of players, say $(m)_{m \in \mathcal{M}}$.

Since the game $\mathcal{G} = (\mathcal{M}, \{\mathcal{S}\}, \{u_i^{\text{MC}}(\mathbf{s})\})$ is an EPG, the potential function $\mathbf{P}^{\text{MC}}(\mathcal{S})$ is guaranteed to converge to a maxima and that maxima in turn corresponds to a pure strategy NE [65]. Hence, a pure strategy NE is unique, depending on the initial subchannel profile and the sequence of play for the strategy update by players. \square

4.4.3 Information Feedback from Neighboring Small Cells

Note that, to compute the utility on a subchannel in Equation (4.11), the serving SAP of a link needs to gather information of all other links in the SCN that are utilizing the particular subchannel. Here, it is assumed that the transmission on a link interferes with all other links over the common subchannel. However, this is not always true in SCNs where the interference sources are dominant only within a neighborhood due to low transmitting power of SAPs [97]. In this regard, I consider each MS aperiodically listens the network to construct a neighbor relation table (NRT) that contains the identity of its neighboring SAPs, and sends back to its serving SAP. For this purpose, the automatic neighbor relation framework introduced in the 3GPP can be utilized to discover neighboring SAPs of the MS [107]. Here, each SAP broadcasts

a unique physical cell identity (PCI), the identifier of the SAP, which the MSs can detect if the reference signal receive power (RSRP) is greater than some threshold value ($RSRP_{TH}$). For simplicity of evaluation, I assume that the RSRP from a SAP is greater than the $RSRP_{TH}$ within their coverage range. Now, the MS lists all the detected PCIs in its NRT, indicating them as its neighboring SAPs, and sends the NRT to the serving SAP. With the PCIs information in the NRT, the serving SAP can establish X2 interface connections with the neighboring SAPs of the MS in order to receive necessary information feedback while computing the utility (the X2 interface allows for inter-cell signaling between SAPs) [34]. Hence, to compute the utility on a subchannel, the serving SAP of a link needs information feedback only of those links originating from the neighboring SAPs that are utilizing the particular subchannel.

Now, the utility function in Equation (4.11) of link i is modified as

$$u_i^{MC}(s_i = k', \mathbf{s}_j) = W_{k'}(s_i, \mathbf{s}_j) - W_{k'}(\mathbf{s}_j) \quad (4.12)$$

Here, $j \in \mathcal{J}_i \subset \mathcal{M}$ is the set of links originating from the neighboring SAPs of link i . The utility function in Equation (4.12) for link i is calculated with the feedback of information only of the links in set \mathcal{J}_i that are also using subchannel k' , i.e., for which the strategy is $s_j = k'$, thus further reducing the computational complexity to compute the utilities.

4.4.4 Distributed Algorithm for Subchannel Allocation

In this subsection, I present a distributed algorithm used by each SAP for subchannel allocation of all links that it handles. In general, there may be a large number of links in a SCN, and the amount of subchannel sensing and information exchange can be overwhelming. Hence, I am looking to limit the amount of subchannel sensing and information exchange requirements. For subchannel allocation, the proposed MCBR algorithm makes decisions based on information obtained from sensing the subchannels where the number of new sensing subchannel is limited to one. Moreover, for the particular sensing subchannel, the algorithm requires information only from those other links that are currently allocated to that subchannel.

Marginal Contribution-Based Best-Response Algorithm

MCBR is described in Algorithm 4. Here, I assume that all SAPs are synchronized and time is divided into time-slots of a fixed duration. Each time slot is further divided into two phases,

called the *sensing* phase and the *payload* phase. Here, I consider the sensing phase alternating with the payload phase. During the sensing phase, SAPs learn the utilities for different subchannels and make the decision to select the subchannel providing with highest utility. In the payload phase, the SAP transmits on the selected subchannel.

In the sensing phase of time-slot t , a link i is selected to update its strategy. During this sensing phase, all other links keep transmitting on the subchannel used in the previous time-slot $t - 1$. The link i selects a new subchannel for sensing according to the subchannel selection probability vector \mathbf{p}_i . Here, $\mathbf{p}_i = \{p_{i,1}(t), \dots, p_{i,K}(t)\}$, where each element $p_{i,k}(t)$ is the probability of choosing subchannel k at time slot t by link i . The SAP for link i measures the utilities on the new sensing subchannel and the subchannel allocated in the previous time-slot, i.e., for strategies $s_i = k'$ and $s_i = k_{t-1}$, according to Equation (4.12). Note that, in order to calculate the two utilities, link i only needs to receive capacity reports of links $j \in \mathcal{J}_i$ that are transmitting on those two subchannels.

Now, the subchannel with highest utility is determined based on the BR dynamics, such that,

$$br_i(\mathbf{s}_j) = \arg \max_{s_i \in \{k', k_{t-1}\}} u_i^{\text{MC}}(s_i, \mathbf{s}_j) \quad (4.13)$$

From Equation (4.13), link i would best respond to switch to the new sensing subchannel k' if the utility $u_i^{\text{MC}}(s_i = k', \mathbf{s}_j) > u_i^{\text{MC}}(s_i = k_{t-1}, \mathbf{s}_j)$. Otherwise, link i would stay with the subchannel selected in the previous time-slot, i.e., subchannel k_{t-1} .

At the end of the sensing phase, the SAP for link i chooses the subchannel with the highest utility for transmission in the payload phase (the rest of time-slot t) and updates the subchannel selection probabilities in \mathbf{p}_i according to the received utility as shown in step 11. The updates of subchannel selection probabilities are dependent on learning the step size (β), normalized utility increment (\tilde{r}_i), and the selected subchannel (k_t) at time-slot t . To understand the update process, let us again consider example 1 with two subchannels $\mathcal{K} = \{1, 2\}$. Suppose for link i at time-slot t the subchannel selection probability vector is $\mathbf{p}_i = \{p_{i,1}(t-1), p_{i,2}(t-1)\} = \{0.5, 0.5\}$ with $\beta = 0.5$, $\tilde{r}_i = 0.5$, and subchannel 1 is selected for transmission in the payload phase, i.e., $k_t = 1$. From the update rule in step 11, since link i has selected subchannel 1, the probability of selecting this subchannel in the next time-slot increases and is given by $p_{i,1}(t) = 0.5 + (0.5) \cdot (0.5) \cdot (1 - 0.5) = 0.625$. On the other hand, the probability of selecting subchannel 2 in the next time-slot decreases and is given by $p_{i,2}(t) = 0.5 - (0.5) \cdot (0.5) \cdot (0.5) = 0.375$. Note that the sum of subchannel selection probabilities of link i at time slot t always equals to 1,

i.e., $\sum_{k \in \mathcal{K}} p_{i,k}(t) = 1$. Such an approach for selecting a new sensing subchannel based on the concept of probability distribution allows for the exploration of more subchannel profiles while minimizing the amount of subchannel sensing and information exchange requirements at each time-slot.

4.4.5 Computational Complexity Analysis

At each iteration in MCBR algorithm, the sensing phase complexity is $\mathcal{O}(2T)$ which results while sensing the new subchannel and the subchannel allocated in the previous time-slot, where T is the duration of the sensing time. The complexity for information feedback from the neighboring links is reflected by $\mathcal{O}(|\mathcal{J}_i|)$, the upper bound, and $\Omega(0)$, the lower bound. This range corresponds to the two extreme cases when the sensing subchannel is also allocated by all other neighboring links and none, respectively. Certainly, the overall computational complexity depends on the number of iterations needed for steady-state convergence, which is not unlimited because of a finite number of possible strategy profiles. In contrast, the identical interest game, which is shown to be an EPG [105, 106], with a potential function and utility function equal to Equation (4.8), has the sensing phase complexity of $\mathcal{O}(|\mathcal{K}|T)$ and the information feedback complexity of $\mathcal{O}(|\mathcal{M}|)$ at each iteration. This is not scalable and would result in significant computational complexity in dense SCN scenarios with large numbers of subchannels. Therefore, the computational complexity of the MCBR algorithm for each iteration is comparatively low and suitable for practical implementation.

Algorithm 4 MCBR used by SAPs for links it handles.

01: Initialization: (at time slot $t = 0$)

02: Get synchronization

03: Set subchannel selection probability of each link as

$$p_{i,k}(t) = \frac{1}{K}, \quad \forall i \in \mathcal{M}, k \in \mathcal{K}$$

04: Randomly select a subchannel k_t for all links i according to the subchannel selection probability vector \mathbf{p}_i

05: In **sensing phase** of time slot $t = 1, 2, \dots$:

06: Select a link i in predetermined round-robin fashion

07: Select a new sensing subchannel k' according to \mathbf{p}_i

08: Receive capacity reports of links $j \in \mathcal{J}_i$ for strategies $s_i = k_{t-1}$ and $s_i = k'$

09: Measure utilities according to Equation (4.12) for strategies $s_i = k_{t-1}$ and $s_i = k'$

10: Determine a subchannel k_t with the highest utility according to Equation (4.13)

11: Update subchannel selection probabilities such that,

$$p_{i,k}(t) = \begin{cases} p_{i,k}(t-1) + \beta \tilde{r}_i (1 - p_{i,k}(t-1)), & \text{if } k = k_t \\ p_{i,k}(t-1) - \beta \tilde{r}_i p_{i,k}(t-1), & \text{otherwise} \end{cases}$$

where $0 < \beta = \frac{1}{K} < 1$ is learning step-size, and \tilde{r}_i is normalized utility increment given by

$$\tilde{r}_i = \frac{u_i^{\text{MC}}(s_i = k_t, \mathbf{s}_j)}{u_i^{\text{MC}}(s_i = k_t, \mathbf{s}_j) + u_i^{\text{MC}}(s_i = k_{t-1}, \mathbf{s}_j)}$$

12: In **payload phase** of time slot t :

13: Link i transmits on subchannel k_t

14: Set $t \leftarrow t + 1$, go to step 05

Table 4.1: Simulation parameters

Parameters	Values
Carrier frequency	2.0 GHz
Channel bandwidth (B)	1.4 MHz
Number of subchannels (K)	{6, 9, 12, 15, 18}
SAP max. transmit power (P_{\max})	20 dBm
Noise power density	-174 dBm/Hz
Path loss: Between SAP and MS link Between other links	$127 + 30\log_{10}(D)$ $128.1 + 37.6\log_{10}(D)$ where D is link distance in km.
Standard deviation of lognormal shadowing	10 dB (between SAP and MS link) 8 dB (between other links)
Multipath Rayleigh fading	Exponential random variable with unit mean
Penetration loss	0 dB (between SAP and MS link) 20 dB (between other links)

4.5 Simulation Results

In this section, I simulate and evaluate performance of the proposed MCBR algorithm with information feedback from the neighborhood, denoted as MCBR (Neighborhood Information), for different performance metrics. The simulations are performed in MATLAB version R2017b (9.3.0.713579).

I consider deployment of small cells that belong to several operators in a cluster [108]. The small cell cluster consists of small cells uniformly deployed in a circular area of radius R meters. MSs are uniformly distributed around circular coverage of radius r meters of SAPs. For simulations, I choose $R = 100$ meters and $r = 30$ meters. The propagation model considered is 3GPP Model 1 (Table A.2.1.1.2-3) in [109]. The channel gains include path-loss, lognormal shadowing, and multipath Rayleigh fading. The lists of parameters used for simulation are shown in Table 4.1.

I consider three general scenarios in a small cell cluster that can exist depending upon num-

ber of subchannels and MSs associated per SAP. The first scenario, *sparse*, consists of SAPs such that the number of subchannels are greater than MSs per SAP i (i.e., $K > M_i$) for all $i \in \mathcal{N}$. The second scenario, *moderate*, consists of SAPs such that, the number of subchannels are less/equal to MSs per SAP i (i.e., $K \leq M_i$) and the number of subchannels are greater than MSs per SBS j (i.e., $K > M_j$), for all $i, j \in \mathcal{N}$. Finally the third scenario, *dense*, consists of SAPs such that the number of subchannels are less/equal to MSs per SAP i (i.e., $K \leq M_i$) for all $i \in \mathcal{N}$. I evaluate performance of the proposed algorithms for all the three radio resource scenarios. The number of SAPs and MSs, (N, M) , for sparse, moderate and dense scenarios are set to $(10, 15)$, $(10, 55)$ and $(10, 100)$ resp.

The reason for considering the three radio resource scenarios is to show the effectiveness of the proposed scheme in different types of scenarios. For the sparse scenario, the evaluated performance metrics include effects of varying the number of subchannels, convergence analysis, and efficiency comparison with other schemes. One reason for considering the sparse scenario to show the efficiency comparison is that the search for global optimum using an exhaustive search can be performed, while it is intolerably time consuming in the other two scenarios. Finally, for all the three scenarios, I compare the performance of MCBR (Neighborhood Information) with other schemes in terms of Jain's fairness index, average system capacity, average interference, and information feedback requirements from an average number of links.

For comparison, I consider the BR strategy with utility in Equation (2.4) for two different schemes, namely, BR (Simultaneous) and BR (Sequential) [64]. In the simultaneous scheme, all links update their strategies simultaneously, without knowing the strategies that have been chosen by other links. Hence, they are making a simultaneous move. In the sequential scheme, each link take turns to update their strategies for selecting a subchannel that maximizes their utility. I also compare the performance of the MCBR algorithm for the utility function described in Equation (4.11), i.e, with complete information feedback from all other links using a particular subchannel in the SCN, denoted as MCBR (Complete Information).

4.5.1 Performance in Sparse Scenario

In this subsection, I compare the performance of MCBR (Neighborhood Information) in the sparse scenario.

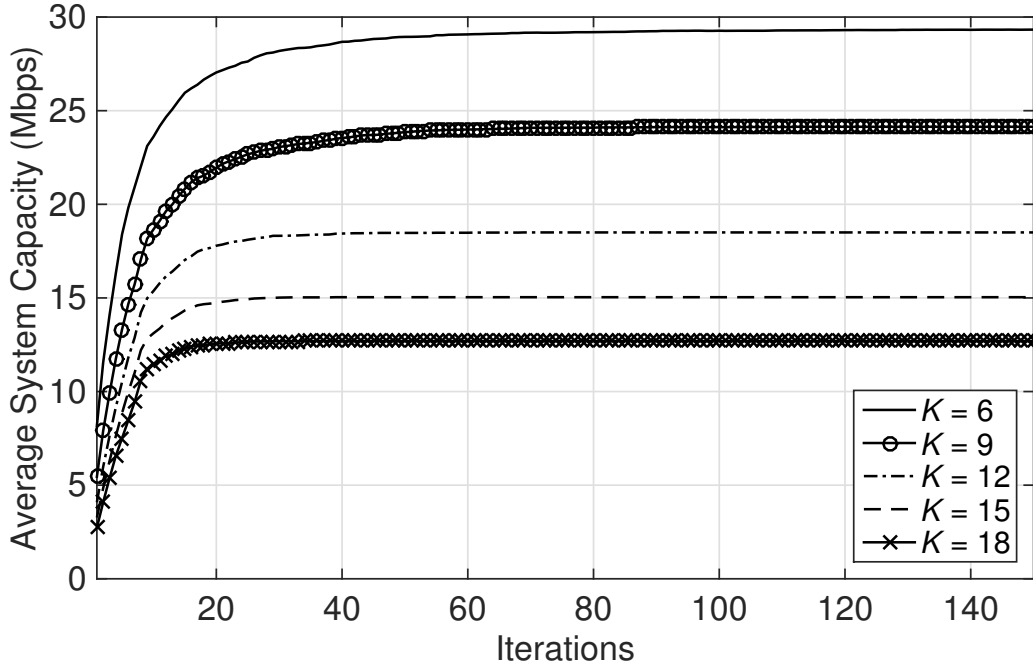

Figure 4.4: Average system capacity with varying numbers of subchannels.

Effects of Varying the Number of Subchannels

First of all, the effect of varying the number of subchannels in MCBR (Neighborhood Information) is demonstrated for $K = \{6, 9, 12, 15, 18\}$. In Figure 4.4, it is noted that as the number of subchannel increases, the subchannel allocation collision decreases; hence the convergence speed to a steady state increases. However, since the total bandwidth is divided with the number of subchannels in Equation (2.4), the achieved total capacity decreases with an increase in subchannels.

For simplicity, in the rest of simulations, I fix the number of subchannels to six.

Convergence Analysis

To show the convergence of MCBR (Neighborhood Information), Figure 4.5 depicts the evolution of the number of links on each subchannel. It is seen that the subchannel allocation converges to a steady state in about 78 iterations. This observation validates the convergence of the proposed MCBR (Neighborhood Information) algorithm.

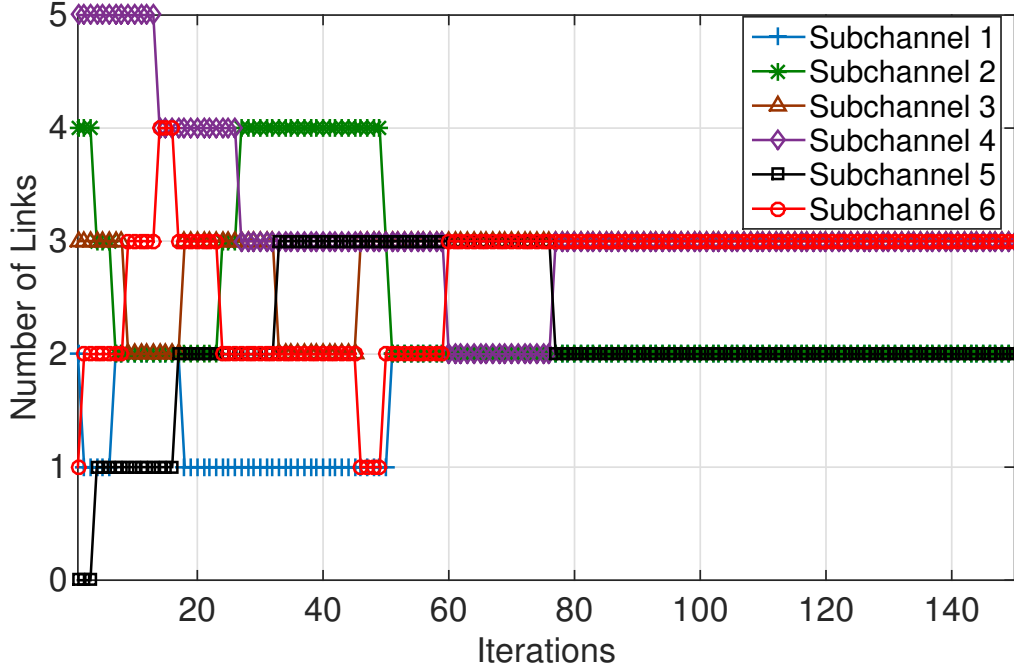

Figure 4.5: The evolution of number of links on each of the subchannels.

Efficiency Comparison

Figure 4.6 tracks the change in system capacity at each iteration and also shows the efficiency of the steady-state convergence. It is noted that CBDSS, SBDSS (with $p = 0.1$ and 0.5), BR (Sequential), MCBR (Neighborhood Information), and MCBR (Complete Information) converge to steady-states after some iterations, while BR (Simultaneous) do not achieve any steady-state solution. Notably, the convergence to a steady-state of CBDSS is significantly faster as compared to other schemes. This is because at most K links can update to their BR subchannel simultaneously at a given time. Also note that, SBDSS (with $p = 0.5$) reaches steady-state faster as compared to SBDSS (with $p = 0.1$). This is due to the fact that SBDSS (with $p = 0.1$) limits more number of players actually updating their strategies at a given time, and hence results with slower convergence. Also, the plots for both MCBR (Neighborhood Information) and MCBR (Complete Information) exhibit the convergence to the pure strategy NE, corresponding to maxima at about 78 and 49 iterations, respectively. This validates that MCBR algorithm is an EPG. As expected, for BR (Simultaneous), the system capacity fluctuates at each iteration and never reaches to steady-state convergence.

Figure 4.7 shows the average values of system capacity obtained for 200 random deploy-

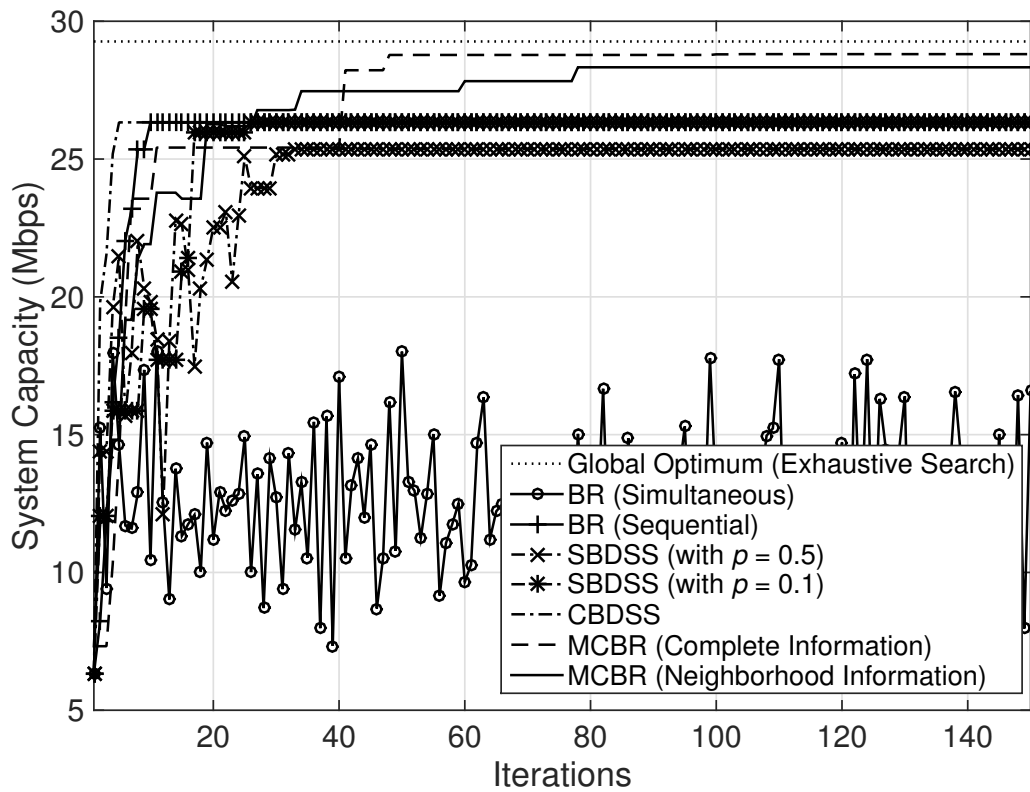

Figure 4.6: System capacity comparison.

ments of the sparse scenario. The performance of MCBR (Neighborhood Information) and MCBR (Complete Information) are close to the optimal solution (obtained from an exhaustive search). The results demonstrate the near-optimal performance of the two MCBR schemes. Note that the convergence speeds to steady states for both MCBR schemes are almost similar and exhibit convergence to maxima. The average performance of CBDSS is significantly faster as compared to all other schemes. The overall average performance of the system capacity is compromised in CBDSS, SBDSS (with $p = 0.1$ and 0.5), and BR (Sequential), where players opportunistically try to maximize their own capacities, whereas the BR (Simultaneous) results in the worst average performance of all when all links update their strategies simultaneously. The results in Figures 4.6 and 4.7 also demonstrates that stochastic BR with small values of p can provide similar effect as sequential move without any requirements of information exchange for coordination among players while updating strategies. Whereas, coordinated actions could allow multiple players to update their strategies at a given time and hence enhance the speed towards steady-state convergence.

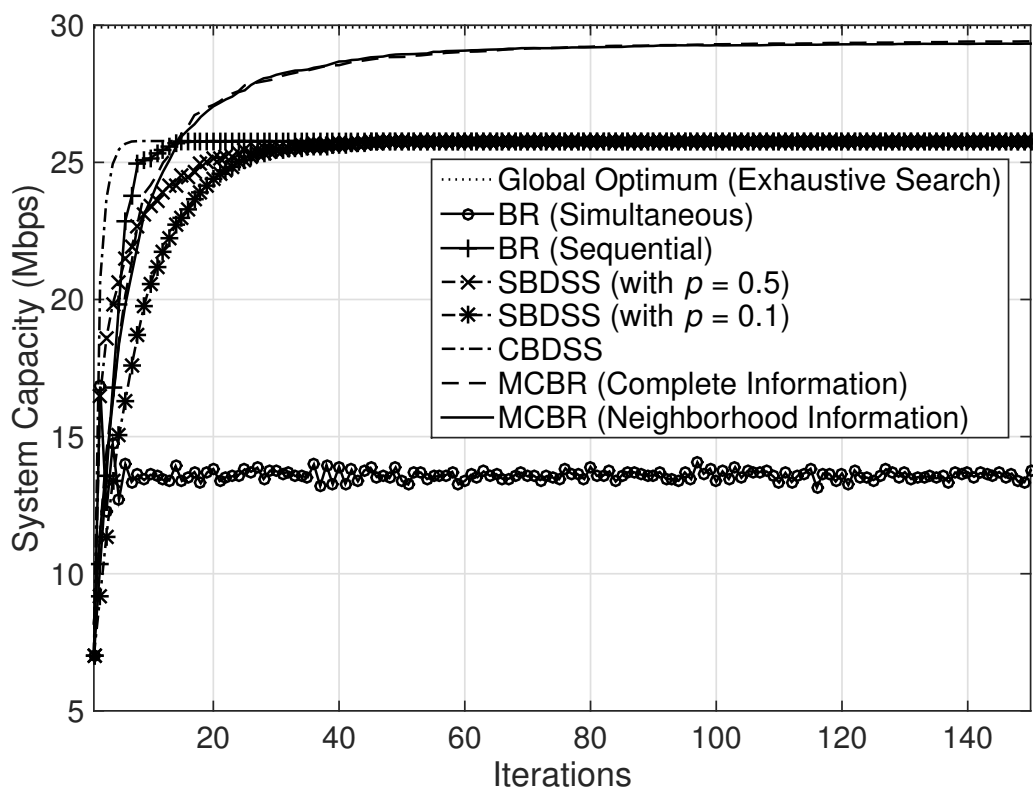

Figure 4.7: Average system capacity over 200 random deployments.

4.5.2 Performance in Different Radio Resource Scenarios

In this subsection, I compare performance of MCBR (Neighborhood Information) with other schemes in all the three radio resource scenarios. I average the performance for 200 randomly generated deployments of each scenario, where the number of iterations is fixed to 500. Moreover, I show 95% confidence intervals in the following figures. Note that for all the schemes, the confidence intervals for the sparse scenario are too small to be visible, which is justified by the plots obtained in Figure 4.7.

First, for the subchannel allocations by all the schemes, I compare fairness in terms of average system capacity obtained by each link. The performance metric I have selected to study this is the fairness index proposed by Jain *et al.* [110]. It determines how fairly the resources are distributed among players where the highest fairness index is equal to 1. This fairness index is widely applied in the literature to evaluate the level of fairness achieved by resource allocation algorithms [87, 93, 111]. Considering a M -link SCN scenario for which link i achieves an average system capacity of $\mathcal{C}_{i,avg}$ from subchannel allocation profiles allocated

Table 4.2: Fairness indices comparison.

	Sparse	Moderate	Dense
Global Optimum (Exhaustive Search)	0.985	–	–
BR (Simultaneous)	0.9705	0.9567	0.9483
BR (Sequential)	0.9694	0.9309	0.8647
SBDSS (with $p = 0.5$)	0.9665	0.9252	0.8741
SBDSS (with $p = 0.1$)	0.9414	0.8971	0.7849
CBDSS	0.9477	0.8859	0.7815
MCBR (Complete Information)	0.9465	0.9095	0.7743
MCBR (Neighborhood Information)	0.9582	0.9197	0.8029

by a scheme, the Jain's fairness index [110] for the scheme is defined as

$$\frac{(\sum_{i=1}^M C_{i,\text{avg}})^2}{M \sum_{i=1}^M C_{i,\text{avg}}^2} \quad (4.14)$$

Table 4.2 displays the fairness indices obtained by the MCBR (Neighborhood Information) algorithm compared with other schemes in the three radio resource scenarios. It can be seen that the optimal solution obtained from an exhaustive search, Global Optimum (Exhaustive Search), provides the highest degree of fairness with an index of 0.985 in the sparse scenario. Note that the search for optimum solution using an exhaustive search is only performed for the sparse scenario since it is intolerably time consuming for the other two scenarios. BR (Simultaneous) is able to maintain the fairness index above 0.9 in all the three radio resource scenarios. However, this performance result comes at an expense in average system capacity as shown in Figure 4.8. From Figure 4.8, notice that there is a trade-off in terms of average system capacity and fairness indices. BR (Simultaneous) is able to maintain higher degree of fairness, as compared to other schemes, but at an expense of achievable average system capacity in all the scenarios. For all the scenarios, both MCBR schemes, MCBR (Neighborhood Information) and MCBR (Complete Information), are able to provide with efficient average system capacity performance and intermediate degree of fairness as compared to other schemes. An explanation for such performance behavior can be attributed to the utility function, i.e., the welfare-based learning rule for the decision-makers, where decision-makers are aware of their influence on others while they are trying to take an action to improve own performance.

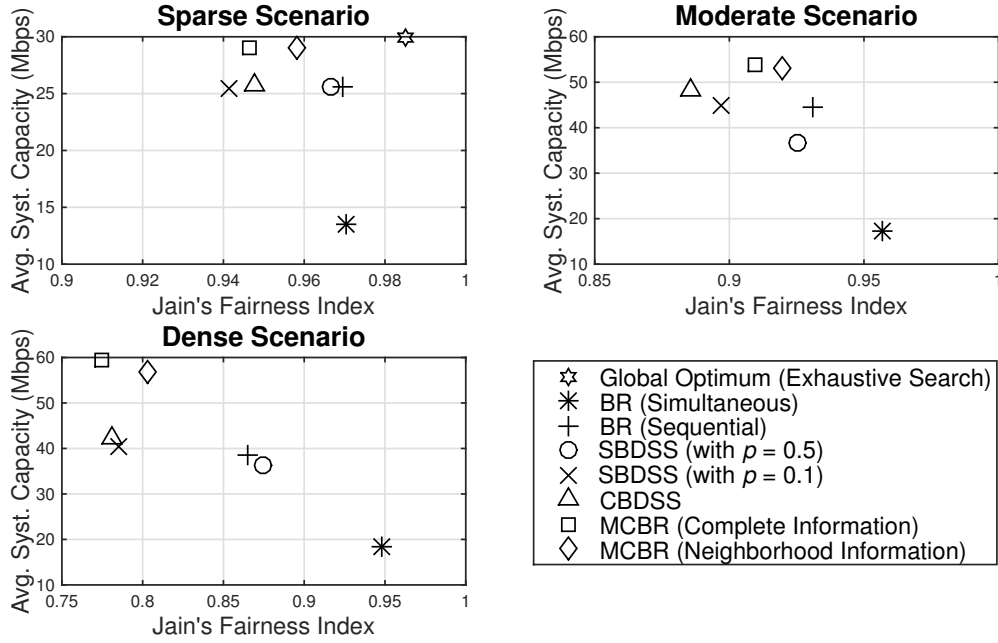

Figure 4.8: Average system capacity versus Fairness.

Figure 4.9 compares the average system capacity for the three radio resource scenarios. MCBR (Complete Information) provides better average system capacity as compared to other schemes, while considerable performance is obtained from MCBR (Neighborhood Information) in all the scenarios. With increasing number of links, the achievable average system capacity from MCBR (Complete Information) and MCBR (Neighborhood Information) increases more quickly than for the other two schemes. MCBR (Complete Information) and MCBR (Neighborhood Information) are able to provide significant performance improvement even in the dense scenarios. CBDSS tends to provide with improved average system capacity as compared to other BR schemes. This is due to the fact that CBDSS converges to a steady-state faster and thus results in improved average system capacity. SBDSS (with $p = 0.1$) and BR (Sequential) have almost similar performance while BR (Simultaneous) provides the worst performance. In addition, the accumulated interference for both MCBR schemes compared to other BR strategy schemes is considerably smaller, as seen in Figure 4.10. For all the schemes, the average interference grows when SCNs becomes denser.

Next in Table 4.3, I evaluate the reduction in average number of links from which information feedback are required for MCBR (Neighborhood Information) compared to MCBR (Complete Information) in the three radio resource scenarios. Recall that in both the MCBR

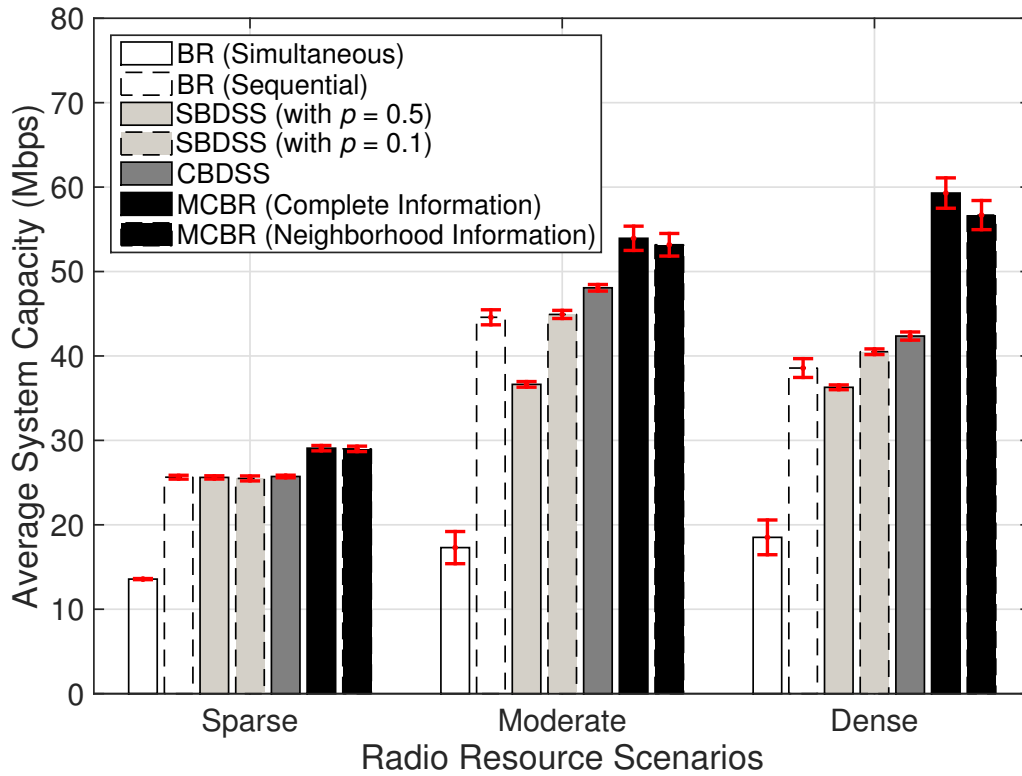

Figure 4.9: Average system capacity in different radio resource scenarios.

schemes, each link requires feedback only from other links that are allocated to the new sensing subchannel and the subchannel allocated in the previous time-slot. Under MCBR (Complete Information), which requires information feedback from all other links in the SCN allocated to the particular sensing subchannel, the average numbers of links for information feedback are 2.65, 12.86, and 46.37 links, respectively. Since MCBR (Neighborhood Information) requires information feedback only of links originating from the neighboring SBSs, the average numbers of links for information feedback drop significantly to 0.94, 4.17, and 12.83 links, respectively, which is a 65–70% reduction in all the three radio resource scenarios. These results show that the computational complexity of MCBR (Neighborhood Information) is low and suitable for practical implementation in different radio resource scenarios of SCNs. From these analysis, I can conclude that MCBR (Neighborhood Information) is able to provide efficient and fair subchannel allocation, even with limitations to complete information feedback in the SCN.

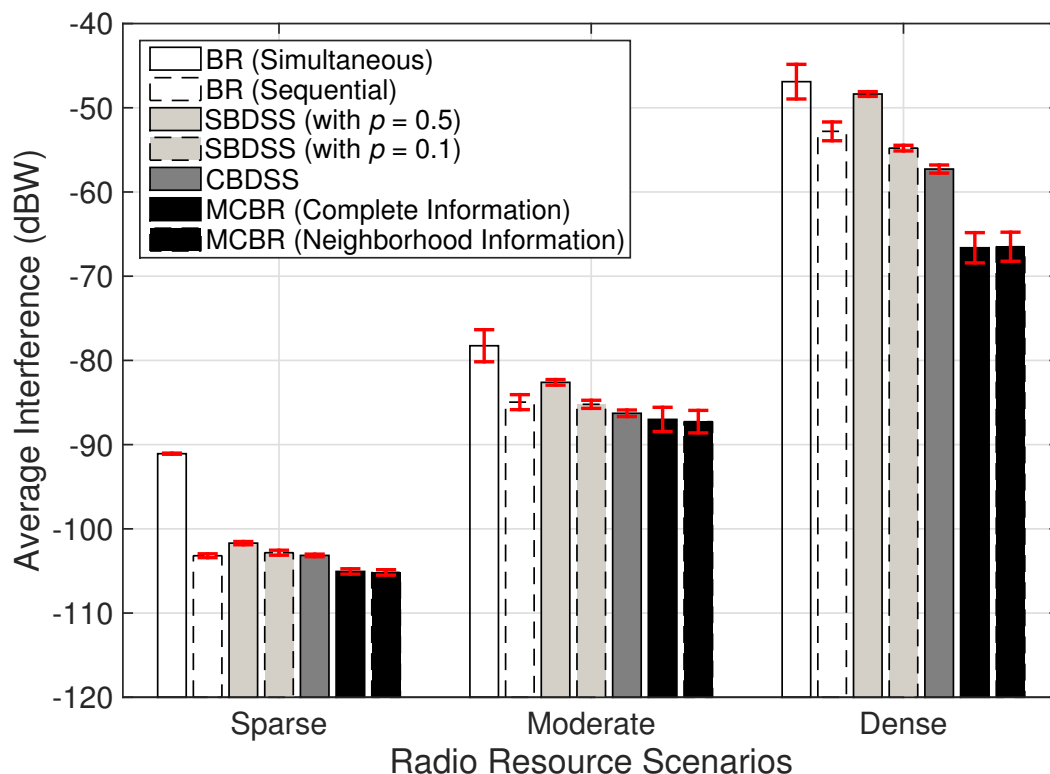

Figure 4.10: Average interference in different radio resource scenarios.

4.6 Summary

In this chapter, I studied and proposed distributed algorithms for subchannel allocation by small cells in non-cooperative and cooperative networks.

In non-cooperative SCNs, with restriction on information exchange and coordination among small cells, each small cell relies on SINR at various subchannels and then responds by selecting the subchannel corresponding to highest-SINR as shown in algorithm 1. Each player regularly senses the SINRs on all subchannels and selects the best subchannel. I discuss in details the case of 3-links-2-channel homogeneous case. If each player selects the best subchannel following a deterministic BR, an oscillation occurs no matter of the initial subchannel selection and it results in lower total capacity. To avoid the oscillation and achieve improved total capacity, while still assuming no information exchange and coordination among the players, I propose algorithm 2 (SBDSS), where each player changes to the best subchannel with some selection probability p , and use a Markov chain to analyze its average capacity performance. In cooperative SCN, algorithm 3 (CBDSS) was proposed, which allows multiple players to update to their

Table 4.3: Information feedback requirements from average number of links.

	Sparse	Moderate	Dense
MCBR (Complete Information)	2.65	12.86	46.37
MCBR (Neighborhood Information)	0.94	4.17	12.83
% reduction	64.53	67.57	72.33

best subchannel simultaneously and speed-up the convergence performance.

Finally, I utilized the concept of MC to design the learning rule for the distributed subchannel allocation problem with an objective to maximize welfare of the SCNs, defined as the total system capacity. The proposed MCBR algorithm requires limited information feedback, i.e., only for the sensing subchannel from other links in the neighborhood, and is verified to be an EPG. This low computational complexity makes it suitable for practical implementation in SCNs while it attains the desirable properties of EPGs, as: (1) it ensures existence of a pure strategy NE, (2) the pure strategy NE corresponds to the maxima of the potential function, and (3) sequential updates of strategy following BR dynamics result in convergence to a pure strategy NE. Simulation results show that the proposed scheme is able to achieve satisfactory performance than other baseline solutions in terms of convergence speed, system capacity, fairness, and interference. Moreover, it ensures an efficient performance close to that obtained with a centralized exhaustive search. From the analysis, I conclude that efficient and considerate fair performance is achievable for the distributed subchannel allocation problem when decision-makers are aware of their influence on others while they are trying to take an action to improve own performance.

Chapter 5

Collaborative Multi-Operator Management and Control

5.1 Introduction

The current evolution in wireless cellular networks are expected to provide ubiquitous network access to the users at anytime and anywhere [3]. With an exponential growth of the mobile users, the demands to provide seamless connectivity with desired level of services to subscribers become an important challenge for MNOs. The current SCNs deployment scenarios (for both indoor and outdoor locations) usually support users of only one MNO [66], which means that with multiple MNOs in one location, users are isolated to separate cells of their respective MNO. For a MNO to consider provision of its network resources to competitors' users involve technical aspects as well as other regulatory aspects [68, 69]. For instance, MNO with exclusive rights to spectrum would have little incentive to share their precious spectrum with other MNOs despite significant researches [112] and regulatory efforts [54, 69], as the mobile market is mainly characterized by high upfront cost of acquiring spectrum licenses [70].

Generally, subscribers are in contract with MNOs, where the services are often chosen by them. Service level agreement (SLA) is the contract that is agreed upon in written form that remains static during certain period of time [113]. However, a MNO might not have enough resources and/or coverage (radio networks availability) everywhere, while others might have under-utilization of their available resources that would result them with decrease in revenues. In order to maintain desired level of services to users and avoid under-utilization of resources,

MNOs could collaborate with other MNO(s) to sustain their service to users in any dynamic environment, considering active users' density and resources availability. This would however require MNOs to reach a beforehand agreement on service policies that would allow network resources utilization by users belonging to the other. For this propose, negotiation to reach a possible agreement on services and form collaboration between MNOs becomes necessary. This chapter presents a brief operation of the CMM module in CCRM framework, in Figure 3.9, that enables collaboration among multiple MNOs to serve users irrespective of their association with a particular MNO. The proposed approach allows a MNO to negotiate for services with other MNOs whenever their own network is unable to sustain services to its MSs, while it motivates the other MNO to reach an agreement considering an increase in revenues by allowing extra users to get service from their under-utilized network resources.

5.2 State-of-the-Art for Multi-Operator Network Sharing

In the near future, the number of wireless devices that are accessing mobile networks are expected to outnumber the human population [1]. As such, management and proper utilization of the licensed spectrum by MNOs to provide desired level of services to their subscribers will be an important issue [114]. In [115], the authors argues that network sharing should not be taken as a threat to hinder competition among MNOs, rather with proper regulatory framework, as a key approach to enhance affordable advanced services. Initially, network sharing was exclusively viewed as an alternative to capital expenditure (CAPEX) reduction, however it has potential to many other strategic benefits by appropriate understanding and regulation of various market players [115]. Two network sharing standards are defined by 3GPP: *multi-operator core network* (MOCN) and *gateway core network* (GWCN). In MOCN, only the radio access network (RAN) is shared where the shared RAN is directly connected to each of the MNOs core networks, while in GWCN, elements of the core network are shared as well to form a shared core network so that the interconnection of the MNOs core networks is done at the core network level [54].

Although there are various approaches to network sharing options available for MNOs [115], it can be simplified to *passive* and *active* sharing. Passive sharing involves MNOs to share BS sites, building premises, and masts. Whereas, active sharing provides virtualization of the shared physical resources, such as *infrastructure* and *spectrum*. Infrastructure sharing and

spectrum sharing are considered to be prominent solutions to utilize the existing resources more efficiently [28].

Infrastructure sharing allows the subscribers of one MNO to utilize the RAN of another MNO(s) to improve the coverage or capacity offered to the subscriber. This allows users to freely switch between the networks of multiple operators. Considering conventional cellular networks as an example, the spectrum bandwidth is divided into frequency bands and different operators transmit over different frequency bands. This in turn improves the coverage in an under-served areas while reducing the requirement of increment in BSs deployment [28].

In [31], the authors introduced *intra-cell roaming-based* infrastructure sharing mechanism that exploits the coexistence of multiple MNOs in the same area. It combines infrastructure sharing and BSs switching-off techniques that enable MNOs provide themselves with benefits of operational cost (OPEX) reduction and energy saving.

Multi-operator spectrum sharing, which refers to the ability of operators to jointly agree upon sharing some parts of their licensed spectrum, has been gaining research interests [28, 99, 112, 114, 116–118]. It provides an opportunity to proper utilization of the exclusively licensed (dedicated) spectrum that remains under-utilized at various times [29]. In spectrum sharing, an operator is able to access the exclusive spectrums of other operator(s).

The usage of the shared spectrum can be divided into two categories: *orthogonal* and *non-orthogonal* [118]. In orthogonal spectrum sharing, MNOs exclusively assign the spectrum from the common spectrum pool, and in non-orthogonal spectrum sharing, more than one MNOs simultaneously allocates spectrum from the common spectrum pool at any particular time. However, for both of the spectrum sharing approaches, a mutual agreement among operators should be reached upon the shared spectrum usage policy.

In [116], the authors studied the performance of orthogonal spectrum sharing, where at any given time only a MNO was allowed to use the spectrum from the shared pool. Their results show significant improvement in system capacity when MNOs share whole portion of their spectrum. Similarly in [117], a mechanism was designed for spectrum allocation to achieve flexible spectrum usage among two MNOs. Here, the whole spectrum pool of the two MNOs were further divided into dedicated and shared portions, and spectrum allocation procedures were carried out based on clustering approach. Moreover, in [118], performance evaluation for two MNOs' network with orthogonal spectrum sharing demonstrated via emulation shows

sharing as an important aspect to enhance the overall system capacity. The work in [112] try to optimize the long term usage of spectrum, where unused spectrum were shared orthogonally and equally between overloaded operators in both centralized and distributed manner. Recently, [99] studied non-orthogonal spectrum sharing in multi-operator small cell networks using many-to-one matching game framework (where a subchannel from the shared spectrum can be assigned by one or more operators simultaneously) with an objective to maximize the sum rate from spectrum allocations.

The work in [98] has studied the economics of spectrum sharing by enabling profit sharing mechanism among MNOs. They consider a set of MNOs with fixed market share and individual spectrum licenses, who weighs on either to upgrade their RAN or enter into spectrum sharing in order to improve both the service provided to their users and revenues. A coalition is formed when all or a set of MNOs agree upon sharing there spectrum, i.e., pooling individual spectrum together for all other MNOs in coalition. Two cost division mechanism among MNOs in coalition are also studied, with and without profit sharing, which are based on cooperative game theory models. However, stability of the coalition is mainly dependent upon the market share (customer base) and spectrum share of MNOs. However, both of the spectrum sharing approaches, orthogonal and non-orthogonal, would not be feasible without a prior mutual agreement among MNOs upon the shared spectrum usage policy.

Moreover, from the study in [28], it indicates that each type of sharing has its own associated gains. The work compares the gains from infrastructure, spectrum and full sharing (combination of both). While spectrum sharing results with improved achievable data rate, infrastructure sharing provides with improved coverage. Full sharing had significant increase in the average data rate, but lower coverage improvement as compared to infrastructure sharing scenario.

Small cEllS coordination for Multi-tenancy and Edge services (SESAME) [119], an European research project for 5G infrastructure public private partnership (5G-PPP) [120], provides a first conceptual approach that focuses on to design and develop a novel 5G platform based on concept of small cells to enable multi-tenancy coupled with an edge-based virtualized execution environment. SESAME proposes a cloud-enabled small cells (CESC) concept at the edge of the small cell networks that offers computing, storage, and radio resources. Through virtualization, the CESC cluster can be seen as a cloud of resources which can be sliced to enable multi-tenancy. The 3GPP based RAN sharing concept, MOCN [54], can be considered

as an exclusive enabler for multi-tenancy features in SESAME. In SESAME, the CESC cluster can be viewed as acting as a neutral host [66] for multiple MNOs to share some part of their network resources, while the tenant MNOs can be viewed as MVNOs [3] that rely on leasing resources from the CESC to offer services to their customers.

Coverage is considered as one of the most important issue to customers and an important dimension for MNOs to compete [115]. Other issues such as brand name and customer service becomes irrelevant if the MNO could not provide coverage in the areas of customers' interest. Traditionally with macrocell coverage, infrastructure were precious and sharing the physical location with competitors could result losing differentiation for a MNO. But with small cells, differentiation on such basis is less of an importance since the deployment cost of small cells are largely reduced [5]. However, a MNO can still remain a major player based on its ownership of the licensed spectrum. Hence, it is required that to offer multi-operator small cells support in SCN, a MNO should consider negotiation with multiple MNOs and reach an agreement with suitable MNO(s) that offers each party with collaboration gains, as a motivation for sharing network resource.

The main contributions of this chapter are summarized as below:

- The proposed mechanism of multi-operator small cells collaboration can be applicable to SCNs as well as other radio network technologies, which could offer several advantages to MNOs such as: maintain services to users even in an overloaded environment, sustain users' loyalty, avoid under-utilization of available network resources, improve revenues by serving extra users from a market share, and serve users at locations not under network coverage.
- The introduced approach to collaboration by first determining policy profile and then involving in negotiation could be applied to other fields where agents would be motivated to share their exclusive owned resources to other parties.

5.3 Collaboration Management Module

The CMM module introduced in Fig. 3.9 is a logical module placed in the C-RAN that is responsible for establishing collaboration among multiple MNOs to provide desired services to users depending upon dynamic network requirements. CCRM framework is envisioned to per-

form multi-operator network (resource and infrastructure) sharing, however with distinguishable characteristics of establishing motivation to share the precious network resources of a MNO with its competitors through collaboration. The CMM acts as a main entity of the CCRM for enabling multi-operator collaboration. It is responsible to perform two main functionality, as below:

- determine a policy profile of a MNO that depend on its network resources availability and utilization, and
- involve in negotiation and establish mutual agreement with other MNO(s) to utilize/provide network resources from/to others.

The provision of collaboration would ensure a MNO to maintain the desired level of service to their users during changes in network resources availability, such as, during overloaded environment when the user's service level may not be met, or when the MNO's services are not available at a particular location. The multi-operator collaboration is also envisioned to create a bring-your-own-device (BYOD) environment that can enable services to users regardless of their parent MNO service/coverage and maintain ubiquitous mobile service coverage. The collaboration among MNOs would offer some key advantages to operators:

- maintain services to users even in an overloaded environment, and sustain customer loyalty,
- avoid under-utilization of available radio network resources,
- improve revenues from the available network resources by serving extra users from a market share, and
- serve users at locations not under network coverage enabling a BYOD environment.

Seeker MNO and Feeder MNO

Considering the network resources availability and its utilization, a MNO determines to be either a *seeker* (a recipient of service access for some of its users from network resources of other MNOs), to improve services to its users, or a *feeder* (a provider of service access to some users of the seeker MNO), to improve revenue by avoiding under-utilization of its network

resources. Here, I consider revenue incurred by a small cell is calculated according to a fixed data service pricing model [121] defined in terms of average data rate perceived by each user. The total revenue, R_i , of MNO i is given by,

$$R_i = \phi_i M_i \rho_i^{(M_i)} \quad (5.1)$$

where,

- ϕ_i is price per user per unit (bps) of data rate service,
- M_i is number of users getting served by MNO i , and
- $\rho_i^{(M_i)}$ is average per user data rate offered by MNO i for serving M_i users.

5.3.1 MNO's Policy Profile

I assume that the service that each MNO must strictly provide is the minimum average per user data rate. To meet this minimum rate, a MNO may need to use the bandwidth of other MNO(s) to increase the average per user data rate above this threshold. In that case, the MNO who seeks more bandwidth is called a seeker, while those providing additional bandwidth to the seeker are called feeders.

Specifically, suppose MNO S serves M_s users but the current average per user data rate, $\rho_s^{(M_s)}$, is less than the required minimum rate, $\rho_{s,min}$. Hence, MNO S is a seeker since $\rho_s^{(M_s)} < \rho_{s,min}$, “condition to be a seeker”. It will need to find out MNO(s) that can be feeder(s) to serve some m_s number of its current users and improve its average per user data rate, such that, it can now meet the minimum rate, i.e., $\rho_s^{(M_s-m_s)} \geq \rho_{s,min}$.

Suppose for simplicity only one MNO F is a feeder. Let ϕ'_s be the maximum price per user per bps that S is willing to pay to the feeder. This price ϕ'_s is called the *seeker's reservation price*. The average per user data rate that the feeder F can serve with additional m_s users from S is denoted as $\rho_f^{(M_f+m_s)}$. Hence, S is willing to pay F at most $\phi'_s m_s \rho_f^{(M_f+m_s)}$ for the service to m_s users.

Note that there is one constraint to seeker now: (a) $\rho_s^{(M_s-m_s)} \geq \rho_{s,min}$. In the best case, by having the feeder serves m_s users of the seeker, the seeker tries to meet (i) its minimum rate requirement as well as (ii) improve (or not decrease) its revenue. That is, the seeker satisfies the constraint (a) above as well as not decrease its revenue. Specifically, the new revenue with

F serving its m_s users is not less than the current revenue (although not meeting the minimum rate). That is,

$$\phi_s(M_s - m_s)\rho_s^{(M_s - m_s)} + \phi_s m_s \rho_f^{(M_f + m_s)} - \phi'_s m_s \rho_f^{(M_f + m_s)} \geq \phi_s M_s \rho_s^{(M_s)} \quad (5.2)$$

where, the left-hand side is the new revenue with F serving its m_s users and the right-hand side is the current revenue where the seeker serves all M_s users. In the left-hand side, the first term is the revenue from serving $M_s - m_s$ users by the seeker itself (at rate $\rho_s^{(M_s - m_s)}$ bps per user), the second term is the revenue from serving m_s users by the feeder, and the third term is the maximum payment the seeker pays to the feeder calculated with the seeker's reservation price.

From equation (5.2), the upper-bound of the seeker's reservation price ϕ'_s is given as

$$\phi'_s \leq \frac{\phi_s((M_s - m_s)\rho_s^{(M_s - m_s)} + m_s \rho_f^{(M_f + m_s)} - M_s \rho_s^{(M_s)})}{m_s \rho_f^{(M_f + m_s)}} \quad (5.3)$$

I consider the seeker's reservation price ϕ'_s to be the price where it is not improving its revenue, but only meeting the minimum rate requirement. Hence, ϕ'_s is equal to the upper-bound given above.

The feeder F currently serves M_f users at price ϕ_f . It can serve all its M_f users at the average per user data rate higher than the minimum rate requirement, $\rho_{f,min}$. It can support additional m_s^* users of S if $\rho_f^{(M_f + m_s^*)} \geq \rho_{f,min}$, "condition to be a feeder". Hence, if $m_s \leq m_s^*$, then it can support m_s , otherwise at most m_s^* .

In the best case, by serving m_s users of S , F has lower average per user data rate at $\rho_f^{(M_f + m_s)}$. Hence, it must be compensated by the seeker. The feeder also has its own reservation price, ϕ'_f , which is the minimum price that the feeder will accept from the seeker. The feeder has no need to improve its average per use data rate since it already meets the minimum rate, i.e., $\rho_f^{(M_f + m_s)} \geq \rho_{f,min}$. Its only motivation to collaborate with the seeker is in improving revenue from utilizing available spectrum. That is, the feeder will agree to serve m_s users of the seeker as long as its new revenue is better than the current revenue, i.e.,

$$\phi_f M_f \rho_f^{(M_f + m_s)} + \phi'_f m_s \rho_f^{(M_f + m_s)} \geq \phi_f M_f \rho_f^{(M_f)} \quad (5.4)$$

where, the right-hand side is the current revenue from serving M_f users at rate $\rho_f^{(M_f)}$. In the left-hand side, the first term is the new revenue from serving M_f users at the new lower rate $\rho_f^{(M_f + m_s)}$ and the second term is the minimum acceptable payment from the seeker at the feeder's reservation price.

From equation (5.4), the lower-bound of the feeder's reservation price ϕ'_f is given as

$$\phi'_f \geq \frac{\phi_f M_f (\rho_f^{(M_f)} - \rho_f^{(M_f+m_s)})}{m_s \rho_f^{(M_f+m_s)}} \quad (5.5)$$

Similar to the seeker's case, I take the *feeder's reservation price* to be its lower-bound which is the price where the feeder is indifferent between serving the seeker's m_s users or not.

The *agreement price*, $\phi_a(m_s)$, at which the seeker and feeder agree for payment to have m_s users served by the feeder must be negotiated between the seeker and feeder. For the negotiation to be successful, it is required that the seeker's reservation price is higher than the feeder's reservation price and the agreement price is in between. That is, $\phi'_f \leq \phi_a \leq \phi'_s$.

5.3.2 Negotiation for Collaboration

Negotiation is an important phase of collaboration for interacting and reaching to an agreement over some service between participants (in our case it's MNOs). It acts as an effective way where a group of participants are able to reach a mutually acceptable agreement with some service policy [122]. Negotiations can exist in many different forms [123]: *one-to-one*, *one-to-many*, and *many-to-many*. While the latter two cases are dealt with using some form of auction protocol, the former case is often solved using some form of heuristic method [123]. One-to-one negotiation, often termed as *bilateral negotiation* [123–125], involves two participants during negotiation process. In such negotiation, MNOs would exchange proposal offers, representing some acceptable solutions, until either an agreement is reached or the negotiation terminates with a failure. Naturally, individual participant in the negotiation acquires a *getting yes* principles, where participating MNOs would approach with a desire to optimize their own position, even going so far as to win at the expense of their partner. Such policy can be viewed as *win* policy, while giving up as little as possible. The negotiating parties are self-interested, and tries to extract values from service of other.

The negotiation between two participants, seeker and feeder MNOs, is called *negotiation trade*. When a MNO negotiate with a potential candidate, there often have some alternative candidates that co-exist or that may appear in future during the negotiation trade. Such alternative candidates are called *outside options* [124], and contribute to outcome of the negotiation. When there are multiple outside options available for the service, the MNO has two alternatives to execute negotiation trades [123, 124]: 1) *sequential* negotiation with one candidate at a time,

or 2) *simultaneous* negotiation with multiple candidates at a time. The former involves performing negotiation trade with each candidate one at a time, and thus this may result in a lengthy encounters. However, it is comparatively easy to execute as the outcome of one negotiation trade can be used to dictate behavior in subsequent negotiation trades [123]. In simultaneous negotiation, the negotiator executes the negotiation trade in parallel with other negotiation trades. It can significantly speed-up the negotiation process, however coordination behavior among various negotiation trades may be complicated [123].

The negotiation trade in simultaneous bilateral negotiation is different from an auction process, in which participants can be seen as auctioneer and bidder, and other candidates as opponent bidders, as below [124]:

- the information of negotiation trades are not directly observed by outside options, but in auction the bids are observed by all other bidders,
- and, in negotiation, both participants can propose and respond, but in auction only bidders propose.

CMM Negotiation Model

I consider one-to-one negotiation, often termed as bilateral negotiation [124], which involves two participants (a seeker and a feeder) during a negotiation process (negotiation trade). In such negotiation, participating MNOs would exchange proposal offers, representing some acceptable solutions, until either an agreement is reached or the negotiation terminates with a failure. As the bilateral negotiation between a seeker and a feeder is a time-constrained domain, hence, I am interested in simultaneous bilateral negotiation such that a MNO can simultaneously execute several negotiation trades at a time when there are multiple alternative candidates available to a negotiator.

Now, I develop a coordinated model in which various negotiation trades can mutually influence each other. Let a negotiation trade round be denoted by $c \in [1, \dots, C]$. The number of negotiation trades at round c be denoted by $|d_c|$. Now, the collection of negotiation trades at round c is given by

$$\mathcal{D}_c = \{d_j\}_{j=1}^{|d_c|} \quad (5.6)$$

At round c , the participants, seeker and feeder, in the negotiation trade d_j proposes an offer ϕ_{sf}^c or ϕ_{fs}^c , respectively. Following the negotiation strategy in [124], the offer at round c of the

seeker and the feeder are assumed to follow:

$$\phi_{sf}^c = \phi_{\min} + \alpha_s^c(\phi'_s - \phi_{\min}) \quad (5.7)$$

$$\phi_{fs}^c = \phi_{\max} - \alpha_f^c(\phi_{\max} - \phi'_f) \quad (5.8)$$

where, ϕ_{\min} and ϕ_{\max} are initial offers of the seeker and the feeder respectively, and $\alpha_i^c, i \in \{s, f\}$, is a time-dependent function defined as $\alpha_i^c = (\frac{c}{C})^{\frac{1}{\zeta}}$. Here, ζ is used to determine the concession pace at c .^a

Now, I model the response of the seeker and the feeder to an offer in a negotiation trade, $d_j \in \mathcal{D}_c$, as best-response strategy [64], such that at round c ,

- Best-response of seeker MNO, br_s :

$$br_s = \begin{cases} \text{accept}; & \text{if } \phi_{sf}^{c+1} \geq \phi_{fs}^c \\ \text{reject and counter-offer}; & \text{if } \phi_{sf}^{c+1} < \phi_{fs}^c \\ \text{quit}; & \text{if } \phi_{sf}^{c+1} \geq \phi_{f's}^c, f' \in \mathcal{D}_c \setminus d_j \end{cases} \quad (5.9)$$

- Best-response of feeder MNO, br_f :

$$br_f = \begin{cases} \text{accept}; & \text{if } \phi_{fs}^{c+1} \leq \phi_{sf}^c \\ \text{reject and counter-offer}; & \text{if } \phi_{fs}^{c+1} > \phi_{sf}^c \\ \text{quit}; & \text{if } \phi_{fs}^{c+1} \leq \phi_{s'f}^c, s' \in \mathcal{D}_c \setminus d_j \end{cases} \quad (5.10)$$

From above equations (5.9) and (5.10), it can be seen that if any agreement is reached at round c , then the offer is accepted with the most profitable negotiation trade. At such an offer, both negotiators in the negotiation trade agree upon this payment (the agreement price) and consequently quits all other negotiation trades.

^a With $0 < \zeta < 1$, a negotiator takes a Boulware strategy [126], i.e., tends to maintain an offered price until the time is almost exhausted, then concedes to the reservation price quickly. With $\zeta > 1$, a negotiator takes a Conceder strategy [127], i.e., goes to the reservation price rapidly and early. Despite the value of ζ , with a constant reservation price, the offer from seeker (feeder) monotonically increases (decreases) as the negotiation rounds progresses.

5.4 Overall Operation in CCRM Framework

In this section, I briefly summarize the overall basic operational flow in a CCRM framework, i.e., both cooperation for resource allocation within SAPs of a MNO, and collaboration between multiple MNOs as shown in Figure 5.1. The operational flow is described in sequence below:

1. The MCBR algorithm introduced in Chapter 4 is performed by SAPs of a MNO to allocate resources (subchannels) to their MSs. A subchannel, that generates highest utility, is selected for each link and allocated to transmit on it in the *payload phase*.
2. The service provisioned by the SAP to the associated MSs, average per user data rate, are feedback to OAM in the C-RAN. Here, service evaluation process is performed to determine whether minimum average per user data rate is maintained or not.
3. Based on average per user data rate, the MNO determines its policy profile to be either a seeker or a feeder MNO.
4. Simultaneous bilateral negotiation trades are established among other MNOs.
5. Based on best-response strategy, MNOs take actions in a negotiation trade, i.e., either accept, reject and counter-offer, or quit.
6. If an agreement is reached on some offer following best-response strategy, the MNOs configure their radio networks according to service policy agreement. The service policy consists of an agreement price for service to be paid by the seeker MNO, and accepted number of MSs of the seeker MNO to be served by the feeder MNO.
7. Finally at SAP, admission of MSs is performed according to the service policy, and resource allocations to MSs continues by following MCBR algorithm.

5.5 Simulation Results

In this section, I evaluate the performance of collaboration among two MNOs, a seeker and a feeder, for several performance metrics. I consider deployment of small cells that belong to two MNOs in a cluster [108]. The small cells cluster consists of small cells uniformly deployed in a circular area of radius $R = 100$ meters. MSs are uniformly distributed around circular coverage

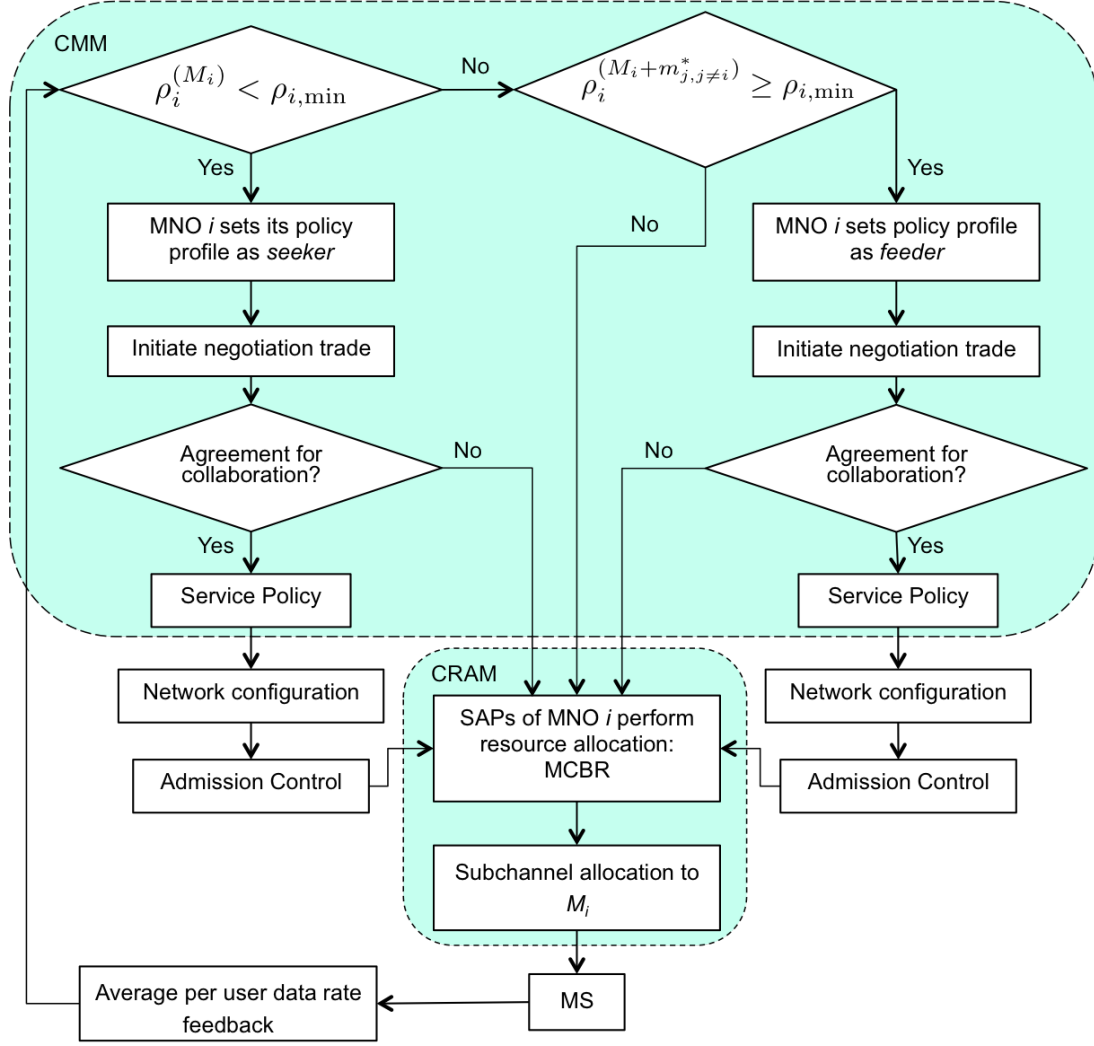

Figure 5.1: Cooperative and collaborative multi-operator operation in CCRM framework.

of radius $r = 30$ meters of small cells. The simulation parameters are same as shown in Table 4.1. The propagation model considered is 3GPP Model 1 (Table A.2.1.1.2-3) in [109]. For simplicity, in simulation, I use channel bandwidth of $B = 1.4$ MHz with corresponding number of subchannels $K = 6$ and maximum transmit power of SBSs set to 20 dBm. The number of deployed SAPs by seeker and feeder are set to 10 each. The number of MSs belonging to seeker and feeder, (M_s, M_f) , are set to $(100, 10)$, unless stated. The average per user data rate threshold is set to 0.5 Mbps per user. I consider $\phi_{\min} = 0$, $\phi_{\max} = 2$, and $C = 10$ rounds with the seeker initiating a proposal offer. Both the feeder and seeker MNOs utilizes MCBR (Neighborhood Information) algorithm, unless stated, for the purpose of resource allocations with the simulation parameters indicated in Table 4.1.

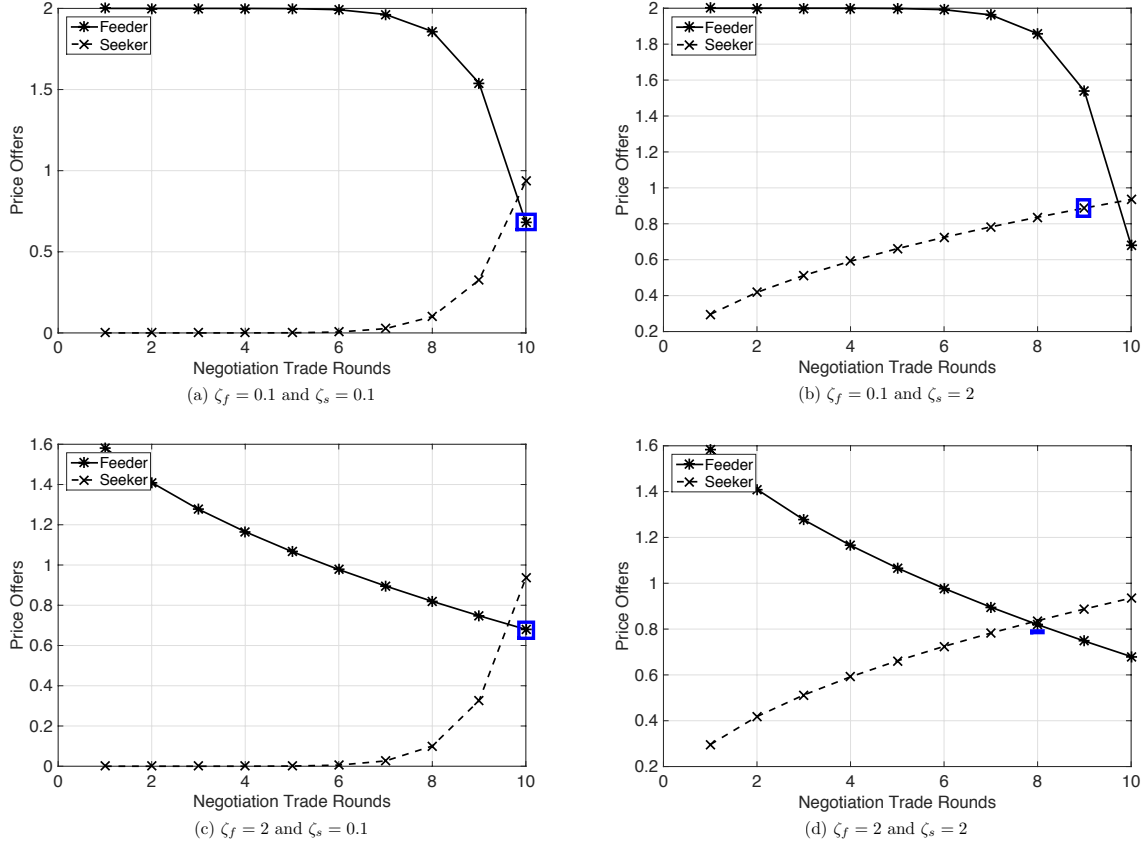

Figure 5.2: Proposal offers of a feeder and a seeker MNO depending upon values of ζ_f and ζ_s i.e., $0 < \zeta < 1$ and $\zeta > 1$, and $M_f = 10$ and $M_s = 100$. A case of agreement in a negotiation trade, where agreement price follows $\phi'_f \leq \phi_a \leq \phi'_s$.

5.5.1 Effects of Strategy in Proposal Offers

In Figure 5.2 (a) - (d), it shows proposal offers made by feeder and seeker MNOs in the negotiation trade by following either Boulware strategy or Conceder Strategy. The number of MSs belonging to the feeder and the seeker MNOs are fixed to 10 and 100 respectively. When both participants follows Boulware strategy, $\zeta_f = 0.1$ and $\zeta_s = 0.1$, I can notice that they maintain their offers until the negotiation trade round c is almost exhausted and then concedes to their respective reservation prices when the negotiation trade almost reaches C rounds. While, if any one of the participant follows a Conceder strategy as shown in Figure 5.2 (b) - (d), the participants offers goes to their respective reservation prices quickly and much early in the negotiation trade of C rounds. Here also, the intersection point of the proposal offers happens as the number of feeder MSs (M_f) is comparatively less than the number of MSs that would provide them with

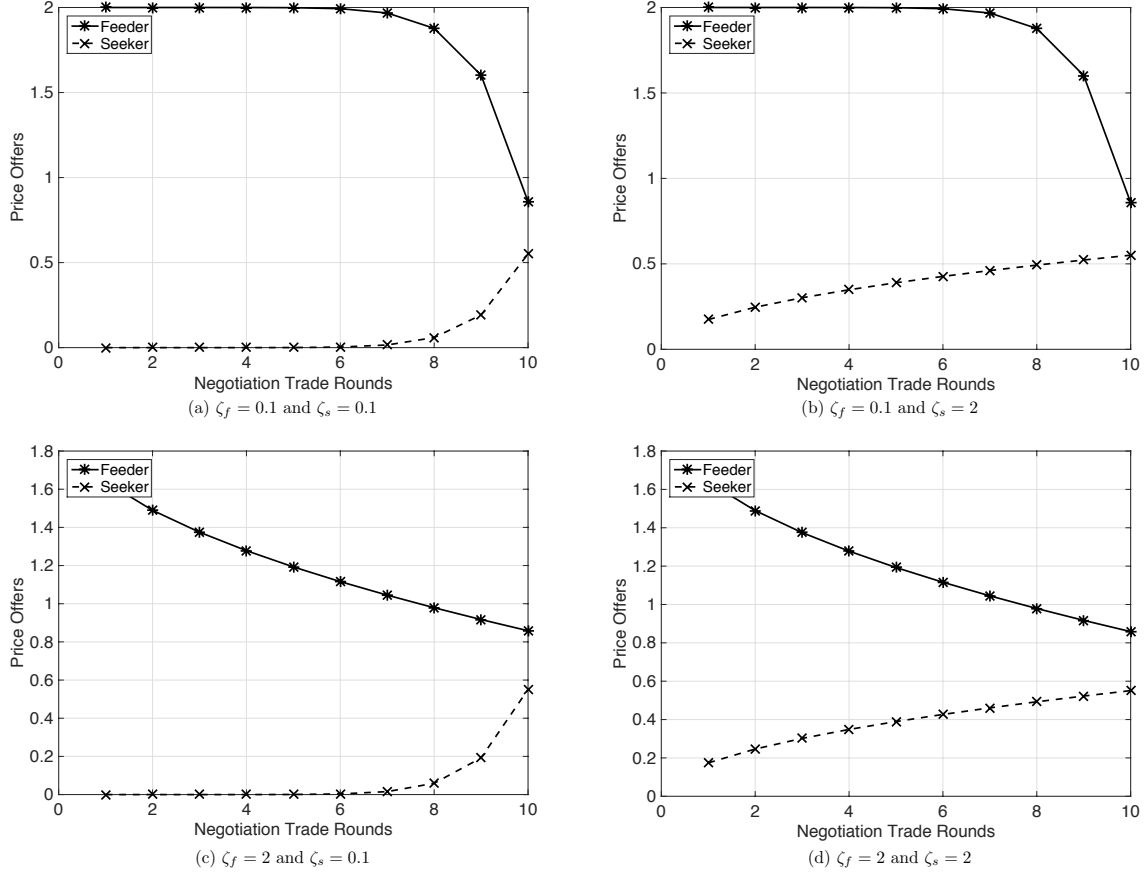

Figure 5.3: Proposal offers of a feeder and a seeker MNO depending upon values of ζ_f and ζ_s i.e., $0 < \zeta < 1$ and $\zeta > 1$, and $M_f = 50$ and $M_s = 100$. A case of no agreement in a negotiation trade.

improvement in revenue from their available network resources. Figure 5.2 (a) - (d) signifies that an agreement is possible in this negotiation trade of C rounds because a proposal offer of either feeder or seeker is favorable to the others following best-response strategy in equations (5.9) and (5.10), and also noting the fact that the agreement price follows: $\phi'_f \leq \phi_a \leq \phi'_s$.

The plots in Figure 5.3 (a) - (d), show a case of no agreement in a negotiation trade. Here, I consider that the number of feeder MSs (M_f) is comparatively higher than the previous plots in Figure 5.2, i.e. $M_f = 50$. In this case, although the feeder and the seeker MNOs enter a negotiation trade, however, no agreement can be reached upon any of the proposal offers. Notably, it supports our analysis for the requirement of an agreement in a negotiation trade, i.e., for the negotiation to be successful, the seeker's reservation price needs to be higher than the feeder's reservation price and the agreement price is in between. That is, $\phi'_f \leq \phi_a \leq \phi'_s$.

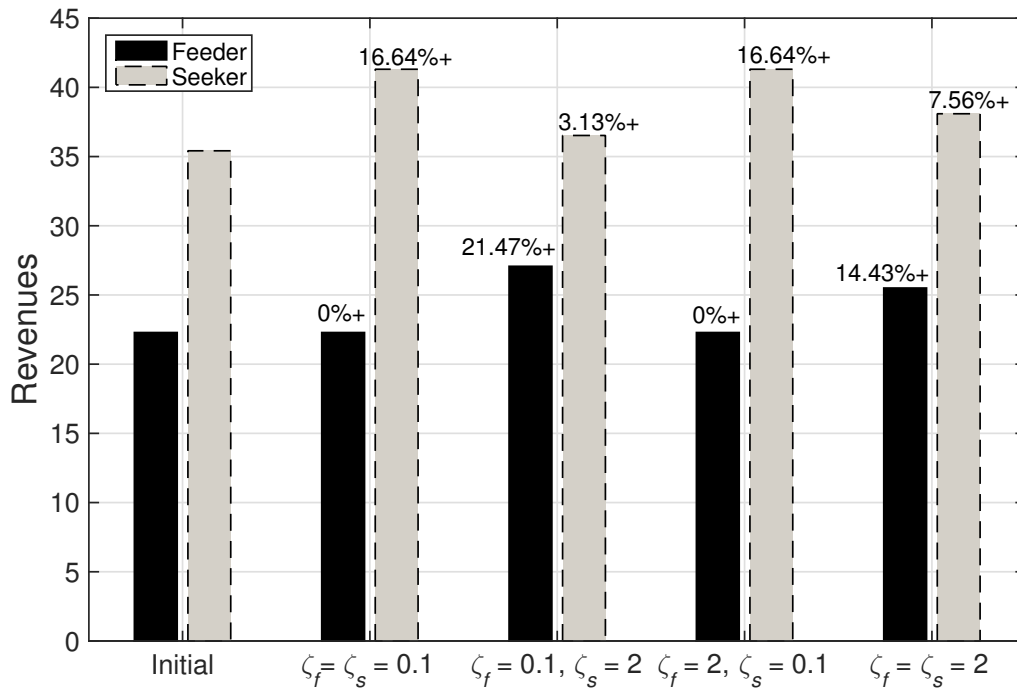

Figure 5.4: Revenues of the feeder and the seeker MNOs depending upon values of ζ_f and ζ_s i.e., $0 < \zeta < 1$ and $\zeta > 1$, and $M_f = 10$ and $M_s = 100$.

5.5.2 Effects in Revenues

Figure 5.4 plots the revenues obtained by the feeder and the seeker MNOs after successful agreement on a proposal offer in a negotiation trade. Once a proposal offer from either a feeder or a seeker is accepted in the negotiation trade and a collaboration is formed, the plots show that both participants would at least benefit with an increment in revenues from their initial revenues. However, the rate of increment from initial revenues are dependent on strategies: ζ_f and ζ_s values. Notice that if any one of the participant is taking Boulware strategy then negotiation agreement could be met at much better offers as compared to its reservation price, and this participant could generate a much better revenues. However, if both participants are following Boulware strategy then the feeder MNO has much improved revenue. The case when the seeker takes Boulware strategy and the feeder takes Conceder strategy is favorable to the seeker as it generates much higher revenues for them as compared to other cases.

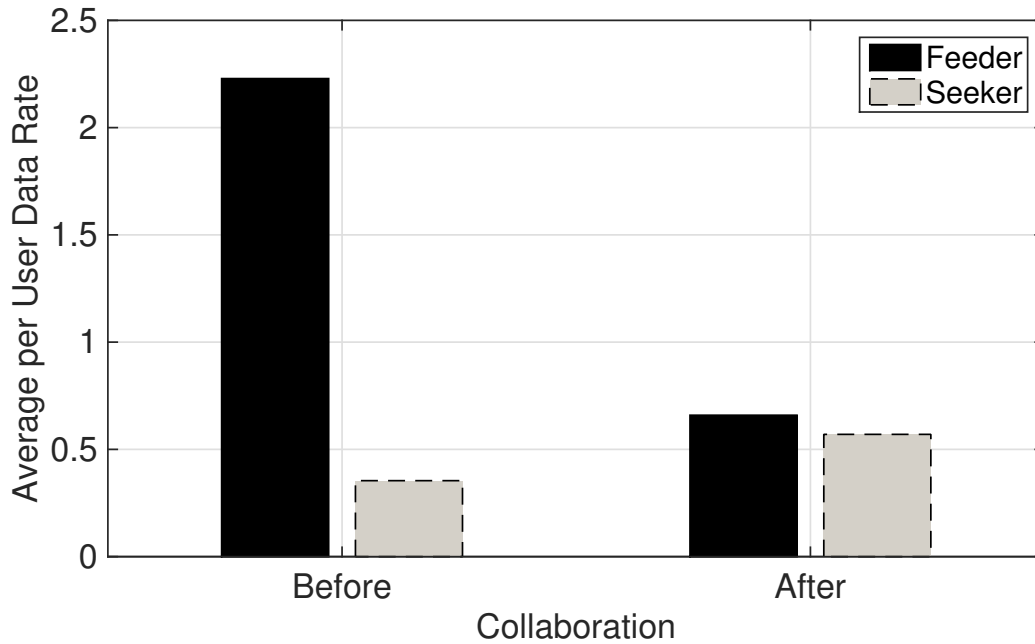

Figure 5.5: Before and after collaboration average per user data rate of the feeder and the seeker MNOs.

5.5.3 Effects in Average per User Data Rate

Fig. 5.5 plots before and after collaboration average per user data rate obtained by users of the feeder and the seeker MNOs. As seen in the plot, notice that average per user data rate of the feeder MNO after collaboration is decreased while the seeker MNO's average per user data rate is increased above the threshold value of 0.5 Mbps per user. This is because both MNOs try to serve possible maximum number of users to increase their revenues while maintaining the required average data rate per user. Following this, the feeder MNO serves some extra MSs of the seeker MNO using its own network resources. While, the seeker MNO improves the average per user data rate by reducing its number of MSs to serve by transferring some of its MSs to get service by utilizing the network resources of the feeder MNO.

5.5.4 Effects in System Capacity

The plots in Figure 5.6 show the system capacity of the seeker MNO that is obtained after collaboration and compared with the case of no collaboration. From the plots, notice that collaboration improves the system capacity of the seeker MNO by enabling some of its MSs served

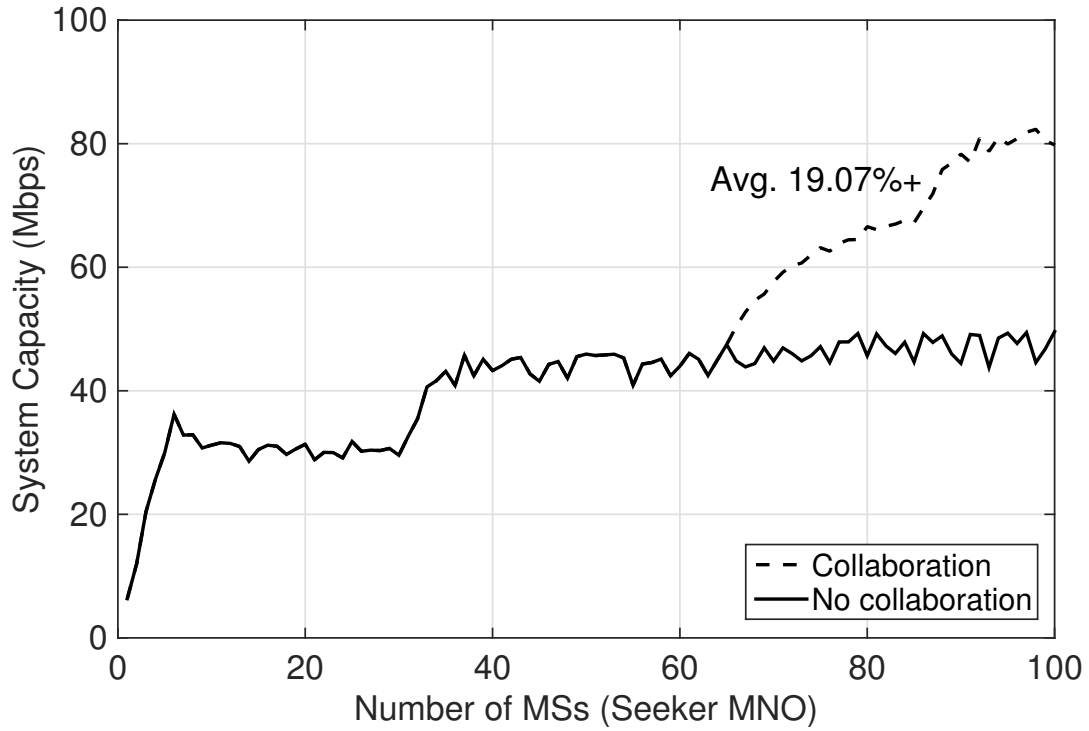

Figure 5.6: Before and after collaboration comparison of system capacity of the seeker MNO.

by utilizing the feeder MNO's network resources. However, the number of MSs getting served by the feeder could be limited depending on the number of MSs belonging to the feeder MNO, M_f . In this regards, the system capacity of the seeker MNO would be dependent on M_f since it dictates how many extra MSs the feeder would be able to serve using its network resources while maintaining the average data rate per user. From simulation, the average number of MSs that the feeder could serve while maintaining the average data rate per user is 56. Hence for given $M_f = 10$, the feeder could collaborate to serve extra MSs belonging to the seeker MNO, i.e., at most $m_s^* = 46$. While, the seeker MNO requires at most $m_s = 35$ number of its users to get served by the feeder MNO to maintain its average data rate per user. Since $m_s \leq m_s^*$, the feeder MNO can serve all of the extra 35 MSs belonging to the seeker MNO. From the Figure 5.6, system capacity of seeker MNO after collaboration is improved as compared to no collaboration in average by 19.07%.

Similarly, for the feeder MNO, the network resources are well utilized after serving extra MSs belonging to the seeker MNO, i.e., $m_s = 35$. Now, the total number of users getting service from the feeder MNO's network resources is increased from $M_f = 10$ to $M_f + m_s = 45$.

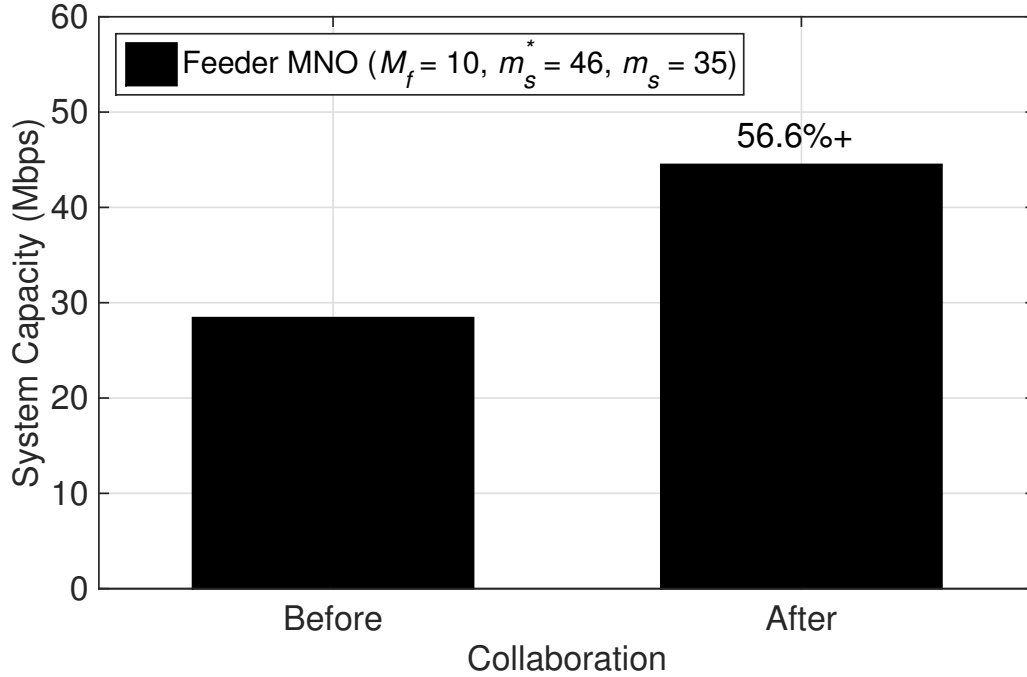

Figure 5.7: Before and after collaboration comparison of system capacity of the feeder MNO.

Moreover, the feeder MNO experience lower average per user data rate at $\rho_f^{(M_f+m_s)}$ while maintaining the average per user data rate than the minimum rate requirement, $\rho_{f,min} = 0.5$ Mbps, as shown in Figure 5.5. Also, the revenues obtained by the feeder MNO after collaboration is not less than the initial revenues as shown in Figure 5.4. Finally from the Figure 5.7, system capacity of feeder MNO after collaboration is improved as compared to no collaboration by 56.6%.

Comparison with Different Resource Allocation Schemes

Now, it is straightforward that small number of M_f could result in more improvement in system capacity for the seeker MNO with collaboration as compared to no collaboration since more number of MSs belonging to the seeker could get served by the feeder. However, the average increment in system capacity would also depend upon the schemes to be used for resource allocations. Hence, here it would be interesting to verify the significance of my proposed resource allocation schemes in Chapter 4, i.e., MCBR. For this purpose, I consider two scenarios with different number of MSs belonging to the feeder MNO: $M_f = 10$ and $M_f = 30$. Now, I compare my proposed MCBR schemes with other BR strategy schemes as mentioned in Chapter 4

with the simulation parameters indicated in Table 4.1. I average the performance for 100 randomly generated deployments of SAPs that belong to two MNOs in a cluster and its associated MSs.

From Figure 5.8, notice that all the schemes has improvement in average system capacity of the seeker MNO with collaboration as compared to no collaboration. Moreover, as the number of M_f increases, compare Figure 5.8 (a) and (b), the corresponding average system capacity improvement after collaboration is decreased for all the schemes. This is due to the fact that now the feeder MNO could serve fewer number of MSs belonging to the seeker. Also, the plots in Figure 5.8 (a) and (b) signifies the benefits of MCBR schemes. As compared to the BR strategy schemes, both proposed MCBR schemes provides with better average system capacity, for both before and after collaboration. Thus, the increment of M_f from 10 to 30 does not have significant effect on the average system capacity of a seeker MNO while using MCBR schemes.

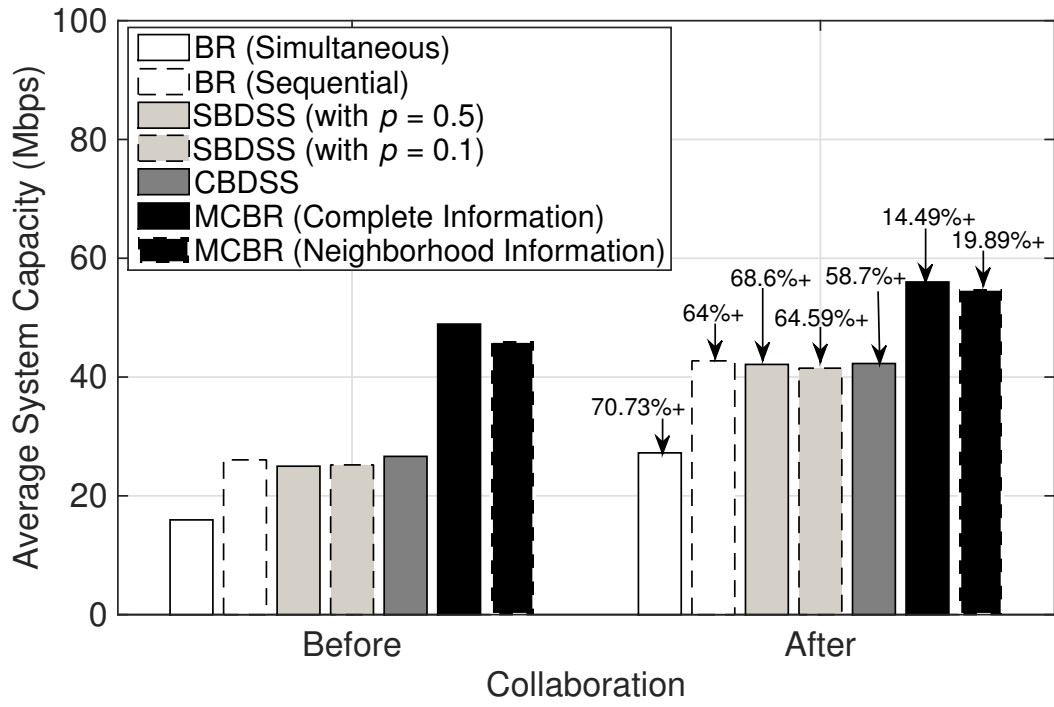

(a)

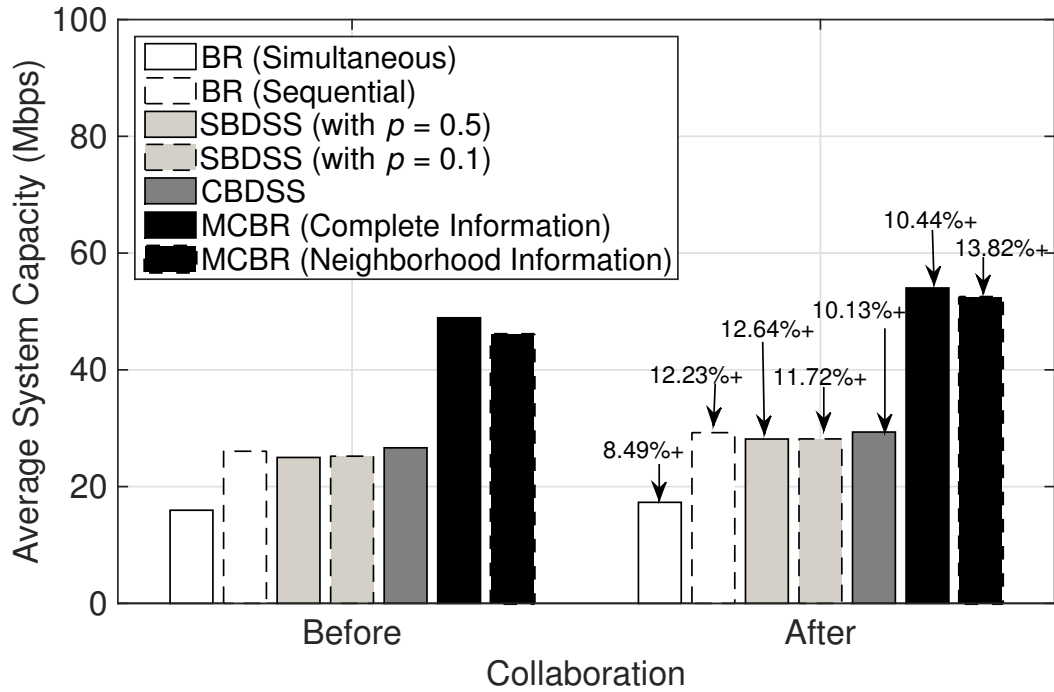

(b)

Figure 5.8: Before and after collaboration comparison of average system capacities of the seeker MNO with different resource allocation schemes. (a) for $M_f = 10, M_s = 100$ and (b) for $M_f = 30, M_s = 100$.

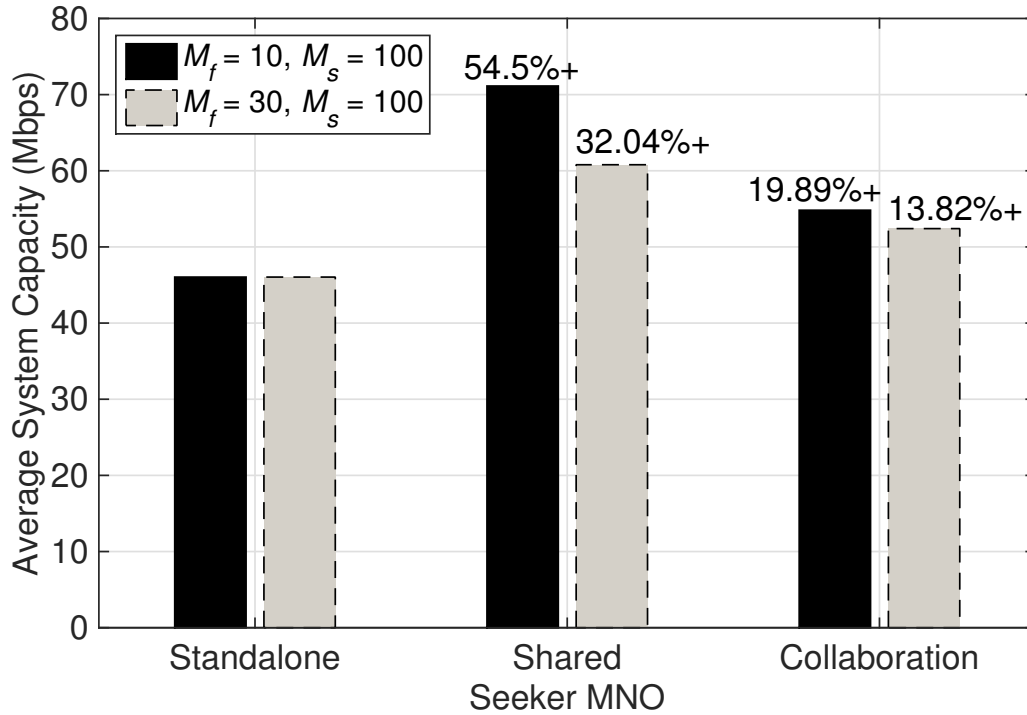

Figure 5.9: Comparison of average system capacities of the seeker MNO while standalone, shared, and in collaboration with the feeder MNO.

Comparison with Shared Networks

The plots in Figure 5.9 compare the average system capacity of the seeker MNO that is obtained while standalone, sharing the network resources with the feeder MNO, and in collaboration with the feeder MNO, for the two cases: (i) $M_f = 10$ and (ii) $M_f = 30$, given $M_s = 100$ remains fixed. Significant improvement in average system capacity can be observed for both cases while sharing the network resources. However note that, there is a significant drop in the average system capacity by 22.46% when M_f is increased from 10 to 30. Sharing the network resources provide with improved average system capacity for both cases as compared to collaboration. But this improvement comes from the fact that the whole network resources of the feeder MNO is utilized by the seeker MNO. Since, the number of MSs belonging to the seeker MNO is comparatively large then that of the feeder MNO, the revenues obtained by each of them following equation (5.1) would not be favorable to both. The indifference in the revenues obtained by the feeder and seeker MNO for the two cases can be observed in Figure 5.10. Unsurprisingly, there is a large decline in revenues of the feeder MNO while

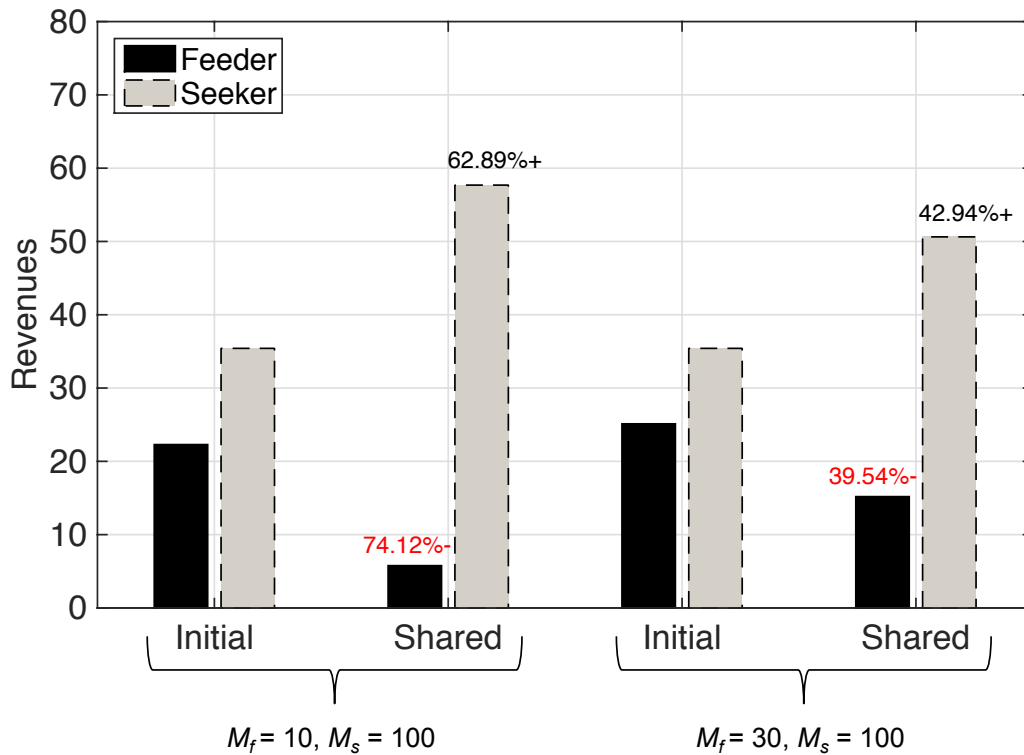

Figure 5.10: Comparison of initial revenues with revenues obtained from sharing network resources of the feeder and the seeker MNOs.

sharing the network resources with the seeker MNO for both cases. Obviously, such a result would not motivate the feeder MNO to share its network resources with the seeker MNO, and hence signifies the importance of considering negotiation to reach an agreement with suitable MNO(s) that could offer each party with collaboration gains as a motivation behind sharing network resources. Also, recall from Figure 5.4 that the revenues obtained by the feeder and the seeker MNO after collaboration for the case of $M_f = 10$ and $M_s = 100$ is not less than the initial revenues.

5.6 Summary

In this chapter, collaboration among MNOs were discussed in details. The essential operations in the CMM module of the CCRM framework such as policy-based multi-operator collaboration and negotiation among MNOs are briefly presented. Depending upon the policy profile of a MNO to be a seeker or a feeder, a negotiation trade can be initiated. An agreement upon a

proposal offers indicate that both the participants in the negotiation trade could benefit while collaborating. Such that, the seeker would benefit by enabling some of their users to get served by the network resources of the feeder MNO. Thus, improving average per user data rate of their users. While, the feeder MNO benefits by serving more users and hence generating more revenues from their under-utilized network resources. Such collaboration ensures that both the participants are achieving benefits such as: improved revenues, enhanced level of services (for MSs of the seeker MNO), and improved system capacity in SCNs.

Chapter 6

Conclusion

6.1 Conclusion and Discussion

In this dissertation, I consider resource management within multi-operator based small cell networks. Radio coverage is one of the most important issue to subscribers and an important dimension for operators to compete. Other issues such as brand name and customer service becomes irrelevant if operators could not provide coverage in the areas of subscribers' interest. Traditionally with macrocell coverage, infrastructure deployment were expensive and sharing physical location with competitors could result losing differentiation for an operator. But with small cells, differentiation on that basis is less of an importance as deployment cost of small cells are largely reduced. However, an operator can still remain a key player based on their ownership of the licensed spectrum. Under such circumstances, network sharing (both spectrum and infrastructure) among multiple operator would be difficult to attain, despite notable network performance enhancement opportunities. To this regard, first of all I present a general network architecture of multi-operator based SCNs that includes feature of cooperative resource allocation and multi-operator collaboration. It promotes network-wide coordination among multiple operators and extension of service from small cells of operators. Thus retaining proper resource utilization by serving subscribers who need not necessarily belong to the operator, i.e., improving subscribers base by providing service to the combined market share of multiple operators.

Considering location centric cooperation among small cells of an operator to perform dynamic distributed resource allocation to its users, I categorize small cell BSs into three groups

based on their functionality: SP, SAP and SPP. SP mainly acts as a relay node for information sharing among neighboring SPs of an operator. SAP performs resource allocation to users that includes coverage and radio resources. SPP acts as a logical point to connect to C-RAN of an operator. It promotes information sharing among small cells in neighborhood that is important to individual SAPs during resource allocation to their users.

To this regard, I introduce CCRM framework that enables multiple operators to reach to an agreement, through negotiation, for collaboration that would allow subscribers of an operator to utilize the network resources of other operators. The multi-operator collaboration is performed at MNOs' C-RAN through which radio network edge resources, both spectrum and infrastructures, of a MNO can be utilized for subscribers belonging to other MNOs. The CCRM framework consists of two main functionality: cooperation among SAPs of a operator for radio resource allocations to their users, and collaboration among multiple operators to enable network resources of one operator to be utilized by subscribers of others.

In chapter 4, I studied variants of BR strategies for SAPs, non-cooperative and cooperative, for the distributed resource allocations problem. Here, I model the problem as a multi-agent game, where each player repeatedly and simultaneously best-responds to others' actions. The traditional BR dynamics rely on the fact that players are coordinated to take turns at best-responding to others' actions and this requires centralized schedulers such that at each time-slot only a single player is chosen to update its strategy, i.e., sequential move. On the other hand, if all players are allowed to switch their strategies at every time-slot (i.e., all players make simultaneous move), an oscillation can occur between some set of strategy profiles, and this would greatly degrade the network performance. To overcome the requirement of centralized coordination in BR strategy, I proposed stochastic BR dynamics based SBDSS algorithm where each SAP updates its strategy with some selection probability. The randomness allows to perform uncoordinated sequential updates without the requirement of any centralized scheduler, and also avoids simultaneous moves that would have resulted with an oscillation among some set of strategy profiles. Next, I show that by regulating players to perform coordinated actions while opting to update to their BR strategies could allow multiple players to switch their strategies at each time-slot. In this regard, I proposed CBDSS algorithm, where with provision of information exchange among SAPs, the total number of SAPs who could simultaneously switch to their BR strategy at each time-slot is increased to at most the number of available strategies. Such

coordinated actions eventually speed-up convergence to a steady-state. However, I noted that strategy update following BR dynamics does not necessarily converge to a pure strategy NE. Hence, to guarantee for the existence of steady-state, I utilized the concept of MC to design the learning rule for the distributed subchannel allocation problem with an objective to maximize welfare of the SCNs, defined as the total system capacity. The proposed MCBR algorithm requires limited information feedback, i.e., only for the sensing subchannel from other links in the neighborhood, and is verified to be an EPG: thus ensures convergence to a pure strategy NE. The simulation results shows that MCBR algorithm is able to achieve significant performance improvement in terms of convergence speed, system capacity, fairness, and interference. Here, I conclude that efficient subchannel allocation is achievable in a distributed network if some sort of self-awareness is introduced to decision-makers' learning rules, such that each decision-maker adapts to improve some measure of the influence caused by its actions to others in the network in addition to improving its own performance.

In chapter 5, I consider for collaboration formation among multiple operators as an motivation for network sharing to allow subscribers of one operator getting service from others. Multi-operator collaboration is beneficial to operators as it provides with collaboration gains to the operators, such as: maintain services to users with improved network resources availability, avoiding situations of under-utilization of radio network resources, improve revenues by providing service to increased subscriber base of the combined market share, and maintain network services to subscribers regardless of coverage through BYOD environment. In short, multi-operator collaboration would allow operators to offer small cells "as a service" to users, with access to wireless connectivity anywhere regardless to their operator's network. An operator determines its policy profile as a seeker or a feeder depending on the resources availability and its utilization. Negotiation trades are established among operators, a seeker and a feeder, such that upon agreement at an offer both collaborating operators are benefited, i.e., *win-win* policy at agreement for both the participants. The negotiation trade participants follow an alternating-offers protocol where the negotiators propose and respond alternatively. The actions, in response to proposal offer, available to the participants are: accept, reject and counter-offer, and quit. Hence, the offer at agreement is acceptable to both of the participants of the negotiation trade. Upon collaboration, the seeker benefits by maintaining services to more users despite having limitation of resources, and also improving their revenues. While

the feeder benefits by improving their subscriber base by serving more users, generating more revenues, and avoiding under-utilization of their network resources.

6.2 Directions for Future Works

The work presented in this dissertation can be extended in several directions considering the trend in cellular wireless networks. Some of the potential direction that can be followed are as below.

6.2.1 Presence of Cooperative and Non-cooperative Small Cells in the Network

First of all, while considering distributed resource allocation among small cells of an operator, there can exist some scenarios where the small cells may or may not follow the best-response strategy dependent on utility defined by the operator. The presence of non-cooperative small cells may influence the performance of other small cells in mutual cooperation with each other. In such cases, it would be necessary to design a motivational framework for those non-cooperative small cells to act in mutual cooperation with others for the benefit of overall network. This would result in forming negotiation between the non-cooperative small cell and the cooperative small cells to reach to an agreement for collaboration such that the network as a whole could benefit.

6.2.2 Subscribers Initiated Service Demands

The collaboration between multiple operators in this dissertation is considered from the operators' point of view. Depending upon resources availability and its utilization, the operators' policy profile to be a seeker or a feeder is determined. Moreover, to make sustainable BYOD environment, subscribers belonging to other operators should be able to initiate service demands from operator(s) in their current location. This would create flexibility to operators to gain market share depending upon their network resources availability and hence potentially overcome under-utilization of their network resources.

6.2.3 Multiple Negotiation Trades

In this work, I presented model for simultaneous bilateral negotiation, where the progress of one negotiation trade can alter the behavior of negotiator in other co-existing negotiation trades. However, in simulation results I presented for only one negotiation trade between a feeder and a seeker. With multiple negotiation trades, the offers proposed by a participant following alternating-offers protocol will be affected by their received offers in other negotiation trades. This would be beneficial to the participant since it will have flexibility to reach to an agreement for collaboration with the one resulting them with most desirable outcome. Moreover, the participant can follow different strategy, either Boulware strategy or Conceder strategy, in simultaneous negotiation trades and manipulate the outcome of the negotiation.

Bibliography

- [1] Cisco, “Cisco visual networking index: Global mobile data traffic forecast update, 2015-2020,” *White Paper*, 2016.
- [2] J. Andrews, H. Claussen, M. Dohler, S. Rangan, and M. Reed, “Femtocells: Past, present, and future,” *IEEE J. on Select. Areas in Commun.*, vol. 30, no. 3, pp. 497–508, 2012.
- [3] E. Hossain and M. Hasan, “5G cellular: Key enabling technologies and research challenges,” *CoRR*, vol. abs/1503.00674, 2015.
- [4] Agilent Technologies, “Introducing LTE-Advanced,” 2010.
- [5] V. Chandrasekhar, J. Andrews, and A. Gatherer, “Femtocell networks: A survey,” *Commun. Mag., IEEE*, vol. 46, no. 9, pp. 59–67, 2008.
- [6] P. Demestichas, A. Georgakopoulos, D. Karvounas, K. Tsagkaris, V. Stavroulaki, J. Lu, C. Xiong, and J. Yao, “5G on the horizon: Key challenges for the radio-access network,” *IEEE Veh. Tech. Mag.*, vol. 8, no. 3, pp. 47–53, 2013.
- [7] O. Fratu, A. Vulpe, R. Craciunescu, and S. Halunga, “Small cells in cellular networks: Challenges of future HetNets,” *Wireless Personal Commun.*, vol. 78, no. 3, pp. 1613–1627, 2014.
- [8] ITU-R M [IMT-TECH], “Requirements related to technical performance for IMT-Advanced radio interface(s),” 2008.
- [9] N. Panwar, S. Sharma, and A. K. Singh, “A survey on 5G: The next generation of mobile communication,” *CoRR*, vol. abs/1511.01643, 2015.
- [10] C. X. Wang, F. Haider, X. Gao, X. H. You, Y. Yang, D. Yuan, H. M. Aggoune, H. Haas, S. Fletcher, and E. Hepsaydir, “Cellular architecture and key technologies for 5G wireless communication networks,” *IEEE Commun. Mag.*, vol. 52, no. 2, pp. 122–130, 2014.

- [11] N. Bhushan, J. Li, D. Malladi, R. Gilmore, D. Brenner, A. Damnjanovic, R. Sukhavasi, C. Patel, and S. Geirhofer, "Network densification: The dominant theme for wireless evolution into 5G," *IEEE Commun. Mag.*, vol. 52, no. 2, pp. 82–89, 2014.
- [12] D. Lopez-Perez, A. Valcarce, G. de la Roche, and J. Zhang, "OFDMA femtocells: A roadmap on interference avoidance," *Communications Magazine, IEEE*, vol. 47, no. 9, pp. 41–48, 2009.
- [13] A. Sabharwal, P. Schniter, D. Guo, D. W. Bliss, S. Rangarajan, and R. Wichman, "In-band full-duplex wireless: Challenges and opportunities," *IEEE J. on Selec. Areas in Commun.*, vol. 32, no. 9, pp. 1637–1652, 2014.
- [14] S. Talwar, D. Choudhury, K. Dimou, E. Aryafar, B. Bangerter, and K. Stewart, "Enabling technologies and architectures for 5G wireless," in *2014 IEEE MTT-S Int. Microwave Symp. (IMS2014)*, 2014, pp. 1–4.
- [15] F. Rusek, D. Persson, B. K. Lau, E. G. Larsson, T. L. Marzetta, O. Edfors, and F. Tufvesson, "Scaling up MIMO: Opportunities and challenges with very large arrays," *IEEE Signal Processing Mag.*, vol. 30, no. 1, pp. 40–60, 2013.
- [16] E. G. Larsson, O. Edfors, F. Tufvesson, and T. L. Marzetta, "Massive MIMO for next generation wireless systems," *IEEE Commun. Mag.*, vol. 52, no. 2, pp. 186–195, 2014.
- [17] Q. C. Li, H. Niu, A. T. Papathanassiou, and G. Wu, "5G network capacity: Key elements and technologies," *IEEE Veh. Tech. Mag.*, vol. 9, no. 1, pp. 71–78, 2014.
- [18] B. Nazer and M. Gastpar, "Reliable physical layer network coding," *Proc. of the IEEE*, vol. 99, no. 3, pp. 438–460, 2011.
- [19] R. Ahlswede, N. Cai, S. Y. Li, and R. W. Yeung, "Network information flow," *IEEE Trans. Inf. Theor.*, vol. 46, no. 4, pp. 1204–1216, Sep. 2006.
- [20] N. Saquib, E. Hossain, L. B. Le, and D. I. Kim, "Interference management in OFDMA femtocell networks: Issues and approaches," *IEEE Wireless Commun.*, vol. 19, no. 3, pp. 86–95, 2012.
- [21] M. S. Jin, S. A. Chae, and D. I. Kim, "Per cluster based opportunistic power control for heterogeneous networks," in *Veh. Tech. Conf. (VTC Spring), 2011 IEEE 73rd*, 2011, pp. 1–5.

- [22] E. Hossain, M. Rasti, H. Tabassum, and A. Abdelnasser, “Evolution towards 5G multi-tier cellular wireless networks: An interference management perspective,” *CoRR*, vol. abs/1401.5530, 2014.
- [23] V. Sridhar, T. Casey, and H. Hammainen, “Flexible spectrum management for mobile broadband services: How does it vary across advanced and emerging markets?” *Telecommun. Policy*, vol. 37, no. 2-3, pp. 178–191, 2013.
- [24] J. Mitola and G. Q. Maguire, “Cognitive radio: Making software radios more personal,” *IEEE Personal Commun.*, vol. 6, no. 4, pp. 13–18, 1999.
- [25] T. D. Novlan, R. K. Ganti, A. Ghosh, and J. G. Andrews, “Analytical evaluation of fractional frequency reuse for ofdma cellular networks,” *IEEE Trans. on Wireless Commun.*, vol. 10, no. 12, pp. 4294–4305, 2011.
- [26] R. Ramanathan and J. Redi, “A brief overview of ad hoc networks: Challenges and directions,” *IEEE Commun. Mag.*, 2002.
- [27] K. Yamamoto, H. Maruyama, T. Shimizu, H. Murata, and S. Yoshida, “Spectral efficiency of fundamental cooperative relaying in interference-limited environments,” *IEEE Transactions on Commun.*, vol. E91.B, no. 8, pp. 2674–2682, 2008.
- [28] J. Kibilda, P. D. Francesco, F. Malandrino, and L. A. DaSilva, “Infrastructure and spectrum sharing trade-offs in mobile networks,” in *2015 IEEE Int. Symp. on Dynamic Spectrum Access Networks (DySPAN)*, 2015, pp. 348–357.
- [29] U. Paul, A. P. Subramanian, M. M. Buddhikot, and S. R. Das, “Understanding traffic dynamics in cellular data networks,” in *2011 Proceedings IEEE INFOCOM*, 2011, pp. 882–890.
- [30] K. Lee, H. Lee, and D. H. Cho, “Collaborative resource allocation for self-healing in self-organizing networks,” in *2011 IEEE Int. Conf. on Commun. (ICC)*, 2011, pp. 1–5.
- [31] A. Antonopoulos, E. Kartsakli, A. Bousia, L. Alonso, and C. Verikoukis, “Energy-efficient infrastructure sharing in multi-operator mobile networks,” *IEEE Commun. Mag.*, vol. 53, no. 5, pp. 242–249, 2015.
- [32] Y. Lin, L. Shao, Z. Zhu, Q. Wang, and R. K. Sabhikhi, “Wireless network cloud: Architecture and system requirements,” *IBM J. of Research and Development*, vol. 54, no. 1, pp. 4:1–4:12, 2010.

- [33] A. Checko, H. L. Christiansen, Y. Yan, L. Scolari, G. Kardaras, M. S. Berger, and L. Dittmann, "Cloud RAN for mobile networks a technology overview," *IEEE Commun. Surveys Tutorials*, vol. 17, no. 1, pp. 405–426, 2015.
- [34] A. Damnjanovic, J. Montojo, Y. Wei, T. Ji, T. Luo, M. Vajapeyam, T. Yoo, O. Song, and D. Malladi, "A survey on 3GPP heterogeneous networks," *IEEE Wireless Commun.*, vol. 18, no. 3, pp. 10–21, 2011.
- [35] H. Claussen, "Performance of macro- and co-channel femtocells in a hierarchical cell structure," in *Personal, Indoor and Mobile Radio Commun., 2007. PIMRC 2007. IEEE 18th Int. Symp. on*, 2007, pp. 1–5.
- [36] J. R. Marden and A. Wierman, "Distributed welfare games," *Oper. Res.*, vol. 61, no. 1, pp. 155–168, Jan. 2013.
- [37] M. S. Alouini and A. Goldsmith, "Area spectral efficiency of cellular mobile radio systems," in *1997 IEEE 47th Veh. Tech. Conf. Tech. in Motion*, vol. 2, 1997, 652–656 vol.2.
- [38] A. Goldsmith, *Wireless Communications*. Cambridge University Press, 2005.
- [39] I. Katzela and M. Naghshineh, "Channel assignment schemes for cellular mobile telecommunication systems: A comprehensive survey," *Commun. Surveys Tuts.*, vol. 3, no. 2, pp. 10–31, Apr. 2000.
- [40] N. D. Tripathi, J. H. Reed, and H. F. Vanlandingham, *Radio Resource Management in Cellular System*. Springer, 2001.
- [41] R. Iyer, J. Zeto, D. Schneider, and L. Kurtz, *Small Cells, Big Challenge: A Definitive Guide to Designing and Deploying HetNets*. CreateSpace Independent Publishing Platform (1832), 2014.
- [42] E. Hossain, L. B. Le, and D. Niyato, *Radio Resource Management in Multi-Tier Cellular Wireless Networks*. Wiley, 2013.
- [43] Small Cell Forum, Available at: <http://scf.io/en/index.php>.
- [44] 3GPP TR 36.932, "LTE; Scenarios and requirements for small cell enhancements for E-UTRA and E-UTRAN (3GPP TR 36.932 version 12.1.0 Release 12)," 2014.

- [45] A. H. Jafari, D. López-Pérez, H. Song, H. Claussen, L. Ho, and J. Zhang, “Small cell backhaul: Challenges and prospective solutions,” *EURASIP J. on Wireless Commun. and Networking*, vol. 2015, no. 1, p. 206, 2015.
- [46] Small Cell Forum Definition, Available at: <http://www.smallcellforum.org/about/about-small-cells/small-cell-definition/>.
- [47] 3GPP Release 13, Available at: <http://www.3gpp.org/news-events/3gpp-news/1771-wlan-lte>.
- [48] D. Chambers, “Femtocell history,” 2008.
- [49] Small Cell Forum, “Femto forum becomes small cell forum as femtocell technology extends beyond the home,” 2012.
- [50] A. Golaup, M. Mustapha, and L. Patanapongpibul, “Femtocell access control strategy in UMTS and LTE,” *IEEE Commun. Mag.*, vol. 47, no. 9, pp. 117–123, 2009.
- [51] 3GPP TS 23.401, “LTE; General Packet Radio Service (GPRS) enhancements for Evolved Universal Terrestrial Radio Access Network (E-UTRAN) access (Release 8),” 2011.
- [52] 3GPP TR 36.808, “3rd Generation Partnership Project; Technical Specification Group Radio Access Network; Evolved Universal Terrestrial Radio Access (E-UTRA); Carrier Aggregation; Base Station (BS) radio transmission and reception (Release 10),” 2012.
- [53] 3GPP TR 36.819, “3rd Generation Partnership Project; Technical Specification Group Radio Access Network; Coordinated multi-point operation for LTE physical layer aspects (Release 11),” 2011.
- [54] 3GPP TS 23.251, “Universal Mobile Telecommunications Systems (UMTS); LTE; Network Sharing; Architecture and functional description (Release 13),” 2016.
- [55] Y. J. Sang, H. G. Hwang, and K. S. Kim, “A self-organized femtocell for IEEE 802.16e system,” in *GLOBECOM 2009 - 2009 IEEE Global Telecommunications Conf.*, 2009, pp. 1–5.
- [56] L. Wang, Y. Zhang, and Z. Wei, “Mobility management schemes at radio network layer for LTE femtocells,” in *VTC Spring 2009 - IEEE 69th Vehicular Technology Conference*, 2009, pp. 1–5.

- [57] H. Zhang, X. Wen, B. Wang, W. Zheng, and Y. Sun, "A novel handover mechanism between femtocell and macrocell for LTE based networks," in *Second Int. Conf. on Commun. Software and Networks, ICCSN '10.*, 2010, pp. 228–231.
- [58] W. Shaohong, Z. Xin, Z. Ruiming, Y. Zhiwei, F. Yinglong, and Y. Dacheng, "Handover study concerning mobility in the two-hierarchy network," in *IEEE 69th Veh. Tech. Conf.*, 2009, pp. 1–5.
- [59] M. Yavuz, F. Meshkati, S. Nanda, A. Pokhariyal, N. Johnson, B. Raghothaman, and A. Richardson, "Interference management and performance analysis of UMTS/HSPA+ femtocells," *IEEE Commun. Mag.*, vol. 47, no. 9, pp. 102–109, 2009.
- [60] D Fudenberg and J Tirole, *Game Theory*. MIT Press, 1991.
- [61] J. V. Neumann and O. Morgenstern, *Theory of Games and Economic Behavior*. Princeton University Press, 1944.
- [62] J. Nash, "Non-cooperative games," *Annals of Mathematics*, vol. 54, no. 2, pp. 286–295, 1951.
- [63] G. Chalkiadakis, E. Elkind, and M. Wooldridge, "Cooperative game theory: Basic concepts and computational challenges," *IEEE Intelligent Systems*, vol. 27, no. 3, pp. 86–90, 2012.
- [64] N. Nisan, M. Schapira, G. Valiant, and A. Zohar, "Best-response mechanisms," in *Proc. of Innovations in Comput. Sci. (ICS)*, 2011.
- [65] D. Monderera and L. S. Shapley, "Potential games," *Games Econ. Behav.*, vol. 14, no. 1, pp. 124 –143, 1996.
- [66] Small Cell Forum Release 7.0, "Market drivers for multi-operator small cells," 2016.
- [67] Small Cell Forum Release 8.0, "Multi-operator small cells," 2016.
- [68] M. Nawrocki, H. Aghvami, and M. Dohler, *Understanding UMTS Radio Network Modelling, Planning and Automated Optimisation: Theory and Practice*. John Wiley & Sons, 2006.
- [69] Small Cell Forum Release 7.0, "Regulatory issues for multi-operator small cells," 2016.
- [70] GSMA Intelligence, "Spectrum for new entrants, lessons learned," 2015.

- [71] 3GPP TS 36.401, “3rd Generation Partnership Project; Technical Specification Group Radio Access Network; Evolved Universal Terrestrial Radio Access Network (E-UTRAN); Architecture description (Release 9),” 2010.
- [72] 3GPP TR 25.814, “Physical Layer Aspects for Evolved Universal Terrestrial Radio Access (UTRA) (Release 7), V7.1.0,” 2006.
- [73] Small Cell Forum Release 7.0, “E-SCN network architectures,” 2016.
- [74] MVNO Definitions, Available at: <http://www.mobile-virtual-network.com/>.
- [75] R. Cellan-Jones, “National roaming - a bad call?,” Available at: <http://www.bbc.com/news/technology-28149227>.
- [76] Press release (23.05.2001): Nokia launches Multi-Operator Radio Access Network for controlled 3G network sharing. Nokia, 2001.
- [77] 3GPP TS 36.300, “Evolved Universal Terrestrial Radio Access (EUTRA) and Evolved Universal Terrestrial Radio Access Network (E-UTRAN); Overall Description; Stage 2 (Release 13),” 2015.
- [78] 3GPP TS 36.420, “X2 general aspects and principles (Release 8),” 2007.
- [79] Small Cell Forum (Release 5), “Small cells, what’s the big idea?,” 2014.
- [80] R. Engelberg, A. Fabrikant, M. Schapira, and D. Wajc, “Best-response dynamics out of sync: Complexity and characterization,” in *Proc. of the Fourteenth ACM Conf. on Electron. Commerce*, ser. EC ’13, Philadelphia, Pennsylvania, USA: ACM, 2013, pp. 379–396.
- [81] Y. Xu, J. Wang, Y. Xu, L. Shen, Q. Wu, and A. Anpalagan, “Centralized-distributed spectrum access for small cell networks: A cloud-based game solution,” *CoRR*, vol. abs/1502.06670, 2015.
- [82] N. Nie and C. Comaniciu, “Adaptive channel allocation spectrum etiquette for cognitive radio networks,” *Mob. Netw. Appl.*, vol. 11, no. 6, pp. 779–797, Dec. 2006.
- [83] Q. D. La, Y. H. Chew, and B. H. Soong, “An interference-minimization potential game for OFDMA-based distributed spectrum sharing systems,” *IEEE Trans. on Veh. Tech.*, vol. 60, no. 7, pp. 3374–3385, 2011.

- [84] R. Xie, F. R. Yu, H. Ji, and Y. Li, “Energy-efficient resource allocation for heterogeneous cognitive radio networks with femtocells,” *IEEE Trans. on Wireless Commun.*, vol. 11, no. 11, pp. 3910–3920, 2012.
- [85] Y. S. Liang, W. H. Chung, G. K. Ni, I. Y. Chen, H. Zhang, and S. Y. Kuo, “Resource allocation with interference avoidance in OFDMA femtocell networks,” *IEEE Trans. on Veh. Tech.*, vol. 61, no. 5, pp. 2243–2255, 2012.
- [86] A. R. Elsherif, W. P. Chen, A. Ito, and Z. Ding, “Adaptive resource allocation for interference management in small cell networks,” *IEEE Tran. on Commun.*, vol. 63, no. 6, pp. 2107–2125, 2015.
- [87] Y. Meng, J. D. Li, H. Y. Li, and P. Liu, “Graph-based user satisfaction-aware fair resource allocation in OFDMA femtocell networks,” *IEEE Trans. on Veh. Tech.*, vol. 64, no. 5, pp. 2165–2169, 2015.
- [88] Y. Xu, J. Wang, Q. Wu, A. Anpalagan, and Y.-D. Yao, “Opportunistic spectrum access in cognitive radio networks: Global optimization using local interaction games,” *IEEE J. of Select. Topics in Signal Process.*, vol. 6, no. 2, pp. 180–194, 2012.
- [89] C. Xu, M. Sheng, X. Wang, C. X. Wang, and J. Li, “Distributed subchannel allocation for interference mitigation in OFDMA femtocells: A utility-based learning approach,” *IEEE Trans. on Veh. Tech.*, vol. 64, no. 6, pp. 2463–2475, 2015.
- [90] Y. Xu, Y. Zhang, Q. Wu, L. Shen, and J. Wang, “Distributed spectrum access for cognitive small cell networks: A robust graphical game approach,” *CoRR*, vol. abs/1502.06667, 2015.
- [91] A. Asheralieva, “Bayesian reinforcement learning-based coalition formation for distributed resource sharing by device-to-device users in heterogeneous cellular networks,” *IEEE Trans. on Wireless Commun.*, vol. 16, no. 8, pp. 5016–5032, 2017.
- [92] M. I. Ashraf, M. Bennis, W. Saad, M. Katz, and C. S. Hong, “Dynamic clustering and user association in wireless small-cell networks with social considerations,” *IEEE Trans. on Veh. Tech.*, vol. 66, no. 7, pp. 6553–6568, 2017.
- [93] J. Qiu, G. Ding, Q. Wu, Z. Qian, T. A. Tsiftsis, Z. Du, and Y. Sun, “Hierarchical resource allocation framework for hyper-dense small cell networks,” *IEEE Access*, vol. 4, pp. 8657–8669, 2016.

- [94] M. Kamel, W. Hamouda, and A. Youssef, "Ultra-dense networks: A survey," *IEEE Commun. Surveys Tutorials*, vol. 18, no. 4, pp. 2522–2545, 2016.
- [95] X. Ge, S. Tu, G. Mao, C. X. Wang, and T. Han, "5g ultra-dense cellular networks," *IEEE Wireless Commun.*, vol. 23, no. 1, pp. 72–79, 2016.
- [96] C. Yang, J. Li, and M. Guizani, "Cooperation for spectral and energy efficiency in ultra-dense small cell networks," *IEEE Wireless Commun.*, vol. 23, no. 1, pp. 64–71, 2016.
- [97] B. Soret, K. I. Pedersen, N. T. K. Jorgensen, and V. Fernandez-Lopez, "Interference coordination for dense wireless networks," *IEEE Commun. Mag.*, vol. 53, no. 1, pp. 102–109, 2015.
- [98] L. Cano, A. Capone, G. Carello, M. Cesana, and M. Passacantando, "Cooperative infrastructure and spectrum sharing in heterogeneous mobile networks," *IEEE J. on Select. Areas in Commun.*, vol. 34, no. 10, pp. 2617–2629, 2016.
- [99] T. Sanguanpuak, S. Guruacharya, N. Rajatheva, M. Bennis, and M. Latva-Aho, "Multi-operator spectrum sharing for small cell networks: A matching game perspective," *IEEE Trans. on Wireless Commun.*, vol. 16, no. 6, pp. 3761–3774, 2017.
- [100] R. Engelberg and M. Schapira, "Weakly-acyclic (internet) routing games," *Theory of Computing Syst.*, vol. 54, no. 3, pp. 431–452, 2014.
- [101] N. Nisan, M. Schapira, G. Valiant, and A. Zohar, "Best-response auctions," in *In Proc. of the 12th ACM conf. on Electron. commerce*, ACM, 2011, pp. 351–360.
- [102] M. Felegyhazi and J.-P. Hubaux, "Game theory in wireless networks: A tutorial," Tech. Rep., 2006.
- [103] E. Koutsoupias and C. Papadimitriou, "Worst-case equilibria," *Comput. sci. review*, vol. 3, no. 2, pp. 65–69, 2009.
- [104] D. Oyama, W. H. Sandholm, and O. Tercieux, "Sampling best response dynamics and deterministic equilibrium selection," *Theoretical Econ.*, 2014.
- [105] Y. Song, C. Zhang, and Y. Fang, "Joint channel and power allocation in wireless mesh networks: A game theoretical perspective," *IEEE J. on Sel. Areas Commun.*, vol. 26, no. 7, pp. 1149–1159, 2008.

- [106] K. Yamamoto, “A comprehensive survey of potential game approaches to wireless networks,” *CoRR*, vol. abs/1506.07942, 2015.
- [107] 3GPP TS 25.484, “3rd Generation Partnership Project; Technical Specification Group Radio Access Network; Automatic Neighbour Relation (ANR) for UTRAN; Stage 2 (Release 10),” 2011.
- [108] 3GPP TR 36.932, “Scenarios and requirements for small cell enhancements for E-UTRA and E-UTRAN (Release 12),” 2013.
- [109] 3GPP TR 36.814, “Further advancements for E-UTRA physical layer aspects (Release 9),” 2010.
- [110] R Jain, *The art of computer systems performance analysis - techniques for experimental design, measurement, simulation, and modeling*. Wiley, 1991.
- [111] H. Zhang, C. Jiang, N. C. Beaulieu, X. Chu, X. Wang, and T. Q. S. Quek, “Resource allocation for cognitive small cell networks: A cooperative bargaining game theoretic approach,” *IEEE Trans. on Wireless Commun.*, vol. 14, no. 6, pp. 3481–3493, 2015.
- [112] P. Luoto, P. Pirinen, M. Bennis, S. Samarakoon, S. Scott, and M. Latva-aho, “Co-primary multi-operator resource sharing for small cell networks,” *IEEE Trans. on Wireless Commun.*, vol. 14, no. 6, pp. 3120–3130, 2015.
- [113] C. Ward, M. J. Buco, R. N. Chang, and L. Z. Luan, “A generic SLA semantic model for the execution management of e-business outsourcing contracts,” in *E-Commerce and Web Technologies: Third International Conference, EC-Web 2002 Aix-en-Provence, France, September 2–6, 2002 Proceedings*, K. Bauknecht, A. M. Tjoa, and G. Quirchmayr, Eds. Berlin, Heidelberg: Springer Berlin Heidelberg, 2002, pp. 363–376.
- [114] Ericsson, “5G radio access,” *The Commun. Technology J. since 1924*, 2014.
- [115] C. Beckman and G. Smith, “Shared networks: Making wireless communication affordable,” *IEEE Wireless Commun.*, vol. 12, no. 2, pp. 78–85, 2005.
- [116] L. Anchora, M. Mezzavilla, L. Badia, and M. Zorzi, “A performance evaluation tool for spectrum sharing in multi-operator LTE networks,” *Computer Commun.*, vol. 35, no. 18, pp. 2218–2226, 2012.

- [117] Y. Teng, Y. Wang, and K. Horneman, “Co-primary spectrum sharing for denser networks in local area,” in *2014 9th Int. Conf. on Cognitive Radio Oriented Wireless Networks and Commun. (CROWNCOM)*, 2014, pp. 120–124.
- [118] E. A. Jorswieck, L. Badia, T. Fahldieck, E. Karipidis, and J. Luo, “Spectrum sharing improves the network efficiency for cellular operators,” *IEEE Commun. Mag.*, vol. 52, no. 3, pp. 129–136, 2014.
- [119] I. P. Chochliouros, I. Giannoulakis, T. Kourtis, M. Belesioti, E. Sfakianakis, A. S. Spiliopoulou, N. Bompetsis, E. Kafetzakis, L. Goratti, and A. Dardamanis, “A model for an innovative 5G-oriented architecture, based on small cells coordination for multi-tenancy and edge services,” in *Artificial Intelligence Applications and Innovations: 12th IFIP WG 12.5 International Conference and Workshops, AIAI 2016, Thessaloniki, Greece, September 16-18, 2016, Proceedings*, L. Iliadis and I. Maglogiannis, Eds. Cham: Springer International Publishing, 2016, pp. 666–675.
- [120] 5G Infrastructure Public Private Partnership (5G-PPP), Available at: [//5g-ppp.eu/](http://5g-ppp.eu/).
- [121] C. Bouras, V. Kokkinos, and A. Papazois, “Financing and pricing small cells in next-generation mobile networks,” in *Wired/Wireless Internet Communications: 12th International Conference, WWIC 2014, Paris, France, May 26-28, 2014. Proceedings*. Springer International Publishing, 2014, pp. 41–54.
- [122] N. R. Jennings, P. Faratin, A. R. Lomuscio, S. Parsons, M. Wooldridge, and C. Sierra, “Automated negotiation: Prospects methods and challenges,” *Group Decision and Negotiation*, vol. 10, no. 2, pp. 199–215, 2001.
- [123] T. D. Nguyen and N. R. Jennings, “A heuristic model of concurrent bi-lateral negotiations in incomplete information settings,” *Int. Joint Conf. on Artificial Intell.*, 2003.
- [124] C. Li, J. Giampapa, and K. Sycara, “Bilateral negotiation decisions with uncertain dynamic outside options,” *IEEE Trans. on Systems, Man, and Cybernetics, Part C (Applications and Reviews)*, vol. 36, no. 1, pp. 31–44, 2006.
- [125] L. Ilany and Y. Gal, “Algorithm selection in bilateral negotiation,” *Autonomous Agents and Multi-Agent Systems*, vol. 30, no. 4, pp. 697–723, 2016.
- [126] H. Raiffa, “The art and science of negotiation,” *Harvard University Press*, 1982.
- [127] D. G. Pruitt, “Negotiation behavior,” *Academic Press*, 1981.

Publications

Journals

- [1] **S. Shah**, S. Kittipiyakul, Y. Lim, and Y. Tan, “Marginal contribution-based distributed subchannel allocation in small cell networks,” *Sensors*, 2018, 18(5), 1500; doi: 10.3390/s18051500 (*Online Published*)
- [2] **S. Shah**, S. Kittipiyakul, and Y. Lim, “Best-response-based distributed subchannel allocation in non-cooperative and cooperative small cell networks,” *Songklanakarin J. of Sci. and Technol. (SJST)*, 2018. (*Submitted: August, 2018, Expected Notification: November, 2018*)
- [3] **S. Shah**, S. Kittipiyakul, Y. Lim, and Y. Tan, “Cooperative and collaborative resource management for multi-operator based small cell networks,” *IEEE Access*, 2018. (*To be submitted: November, 2018*)

International Conferences

- [4] **S. Shah**, S. Kittipiyakul, “Decentralized Subchannel Allocation Strategy for Interference Management in Femtocell Networks,” 8th Int. collaboration Symp. on Inform., Prod. and Syst. (ISIPS 2014), Fukuoka, Japan, 12-13 Nov. 2014.
- [5] **S. Shah**, S. Kittipiyakul, “Best-response Distributed Subchannel Selection for Minimizing Interference in Femtocell Networks,” 1st Int. Conf. on Ind. Networks and Intelligent Syst. (INISCom 2015), Tokyo, Japan, 2-4 Mar. 2015.

- [6] Y. Yu, **S. Shah**, Y. Tan, and Y. Lim, “End-to-end Throughput Evaluation of Consensus TPC Algorithm in Multihop Wireless Networks,” The Int. Wireless Commun. & Mobile Computing Conf. (IWCMC), Dubrovnik, Croatia, 24-27 Aug. 2015.
- [7] **S. Shah**, S. Kittipiyakul, Y. Lim, and Y. Tan, “Multi-operator small cells collaboration using simultaneous bilateral negotiation,” 14th Int. Conf. on Elect. Eng./Electron., Comput., Telecommun. and Inform. Technol. (ECTI-CON), Thailand, 18-21 Jul. 2018.

Local Conferences

- [8] **S. Shah**, Y. Yu, Y. Tan, and Y. Lim, “Best-response Distributed Sub-channel Selection for Minimizing Interference in Cooperative and Non-cooperative Small Cell Networks,” IEICE Tech. Committee on Ambient Intell. and Sensor Networks (ASN), Tokyo, Japan, 2-3 Mar. 2015.
- [9] Y. Yu, **S. Shah**, Y. Tan, and Y. Lim, “A Study on Consensus Transmit Power Control Algorithm to Maximizing End-to-end Throughput in Dense Multihop Wireless Networks,” IEICE Tech. Committee on Ambient Intell. and Sensor Networks (ASN), Tokyo, Japan, 2-3 Mar. 2015.