

Title	VR体験拡張のための直感的かつ没入的なウェアラブルデバイスとインタラクティブドールの開発
Author(s)	李, 仁敦
Citation	
Issue Date	2023-06
Type	Thesis or Dissertation
Text version	ETD
URL	<a href="http://hdl.handle.net/10119/18702">http://hdl.handle.net/10119/18702</a>
Rights	
Description	Supervisor: 宮田 一乗, 先端科学技術研究科, 博士

Doctoral Dissertation

Enhancing Intuitive and Immersive VR Experience with  
Wearable Devices and an Interactive Doll

Lee Jen-Tun

Supervisor: Kazunori Miyata

Graduate School of Advanced Science and Technology

Japan Advanced Institute of Science and Technology

Knowledge Science

June 2023

# Abstract

Over the years, virtual reality (VR) applications combining somatosensory operations have gained popularity, moving beyond entertainment and into medical and educational realms. Wearable sensing devices, robot interaction, and VR devices have evolved, and the user's physical activity can now provide instructions, creating a new type of human-computer interaction. Intuitive operation can make users feel the same sense of operation in the virtual world as in the real world, and the sound, tactile, and visual stimuli directly fed back to the user after the operation can increase the user's sense of presence in the virtual world. However, there are issues with existing hardware devices such as wand controllers and depth cameras, which cannot provide users with intuitive operations (passive interaction). Moreover, current interactive robots can only provide feedback in the physical world. Therefore, the main research problem to be solved through the proposed hardware and software in this research is to provide an intuitive and immersive interaction procedure to increase the immersive experience in VR. This research can be divided into four aspects.

First, the existing VR device controller mimics the user's hands in the virtual world. However, the actual operation method is through the equipped touchpad, trigger, and buttons, using touch, press, or slide to interact and operate with the objects in the game. Therefore, the research proposes a wearable motion tracking device and a VR glove. The researchers aim to combine feedback from gesture operations with VR and somatosensory control to achieve a more intuitive and humanized human-computer interaction (HCI) for head-mounted VR devices.

Second, interactive gestures between users and animals or friends in the real world are usually continuous gestures, such as waving, clapping, and touching. However, existing gesture recognition usually only recognizes static gestures (fist or OK sign). Therefore, this research proposes an algorithm to recognize continuous gesture interactions so that users can interact with characters in the virtual world through gestures, just like in the real world.

Third, in the virtual world, interactive objects between the user and the game are usually classified as objects or virtual characters. However, when the user grabs or pulls the objects in the game through the controller, they cannot feel real feedback. To reproduce the interactive feeling of holding objects of various shapes and behaviors with both hands, this research proposes the use of intuitive manipulation of VR gloves to allow users

to stretch, bend or twist flexible materials and display the corresponding physical deformation on the virtual object. The realization allows users to perceive the difference between virtual and real tactile sensations only with their hands.

Finally, it is not enough to provide only visual feedback in the virtual world but also tactile and auditory feedback in the real world. To achieve an easy-to-read human-computer interaction target interface, the research proposes an interactive doll that can also show how the user's daily behavior is integrated into the virtual world. When interacting with characters, the feedback that virtual characters can bring to users is a very important factor. Therefore, this research will develop an interactive doll that integrates visual, auditory, and physical tactile feedback to simulate the sense of presence brought by the interaction of virtualization and realization. By integrating data gloves, persistent gesture interaction, and interactive dolls, this research aims to provide intuitive and immersive interactions between virtual and physical realities to increase the presence experience in VR.

**Keywords:** Human-Computer Interaction, Free-hand Interactions, Intuitive Manipulation, Virtual Reality, Embodied Operation.

## Acknowledgment

Firstly, I would like to express my sincere gratitude to my advisor Prof. Miyata sensei for the continuous support of my Ph.D study and related, for his patience, motivation, and immense knowledge. His guidance helped me in all the time of research and writing of this thesis. I could not have imagined having a better advisor and mentor for my Ph.D study. Besides my advisor, I would like to thank my co-advisor Prof. Sato sensei, my sub-research advisor Prof. Fujinami sensei and committee members Prof. Noma sensei, Prof. Yuizono sensei, Prof. Nishimoto sensei and Prof. Kanai sensei for their valuable comments and suggestions.

My sincere thanks also goes to Prof. Janaka sensei who has supervised me since I was an undergraduate in BSc Power Mechanical Engineering at National Formosa University, Taiwan. He has been a great inspiration to me and has always encouraged me to pursue my research career. He also provided me an opportunity to work in his lab and who gave access to the laboratory facilities and equipment. Without his precious support it would not be possible to carry out this research work.

I thank my fellow labmates especially Liangyu SHI, for the sleepless nights we were working together before deadlines, and for all the fun we have in the last three and half years. Also I would like to thank my friends and colleagues in the lab for their support and encouragement. I would also like to thank my friend Jiun-Yao Cheng in the University of Florida, for the proofreading and content writing he gave me in the last few weeks.

I would also like to thank Chiang-Chin Chen and her mother for their love and support. They share so much their life experience with me and give me a lot of advice. I would like to thank them for their patience and understanding when I was busy with my research work. Last but not the least, I would like to thank my family: my parents and to my brothers for supporting me spiritually throughout writing this thesis and my life in general.



# List of Figures

1.1	Research Logic Sequence . . . . .	12
1.2	Research Outline . . . . .	13
1.3	NHED model in knowledge Science . . . . .	17
3.1	Research Technical Process . . . . .	33
3.2	Process of achieving Natural Interaction . . . . .	35
3.3	Process of achieving Passive haptic feedback . . . . .	37
3.4	Double-bridge Avatar . . . . .	37
4.1	Overview the process of implementing the recognition continuous gesture with the proposed input devices. . . . .	41
4.2	The PCB layout and CAD of the motion tracking device. . . . .	43
4.3	Motion Tracking Device Program Flowchart . . . . .	44
4.4	VR Glove . . . . .	47
4.5	PCB Layout and Sensors on Glove . . . . .	48
4.6	The PCB schematic of VR Glove . . . . .	49
4.7	VR Glove Program flow chart . . . . .	49
4.8	Comparison of UDP and TCP protocol. . . . .	50
4.9	Unity UDP program flow chart . . . . .	51
4.10	Persistent Gesture Recognition Working Flow . . . . .	53
4.11	Static Gesture performed by VR Glove . . . . .	53
4.12	Static Gestures List . . . . .	54
4.13	Three types of forearm movements acceleration waveform characteristics . . . . .	55
4.14	The prediction results overlaid on the plot of live sensor data. . . . .	56
4.15	Adding and Removing result for updating the List . . . . .	56
4.16	Continuous Gestures List . . . . .	57
4.17	Continuous Gesture Device . . . . .	57
4.18	Gestures Average Percentage . . . . .	58
5.1	Cup stacking tasks . . . . .	64
5.2	The backside of the scene was black, to let the user focus on the cup-stacking task. . . . .	65

5.3	There are no black screens to restrict the user’s eyesight. . . .	66
5.4	The scenario for EEG experiment . . . . .	67
5.5	Types of VR Input Devices. . . . .	68
5.6	EEG raw data with events marked . . . . .	71
5.7	Intuitiveness . . . . .	77
5.8	Immersiveness and Extensibility . . . . .	78
5.9	PSD of Normal, Rotate, Grab, and Scale (Gesture events) for four devices (mean of all subjects). . . . .	79
6.1	Fingertip pression coordinate drawing by raycast in Unity. . .	87
6.2	Force Direction Offset. (A) represents the force direction before giving offset value. (B) represents the force direction after giving offset value. . . . .	87
6.3	Rounded Cuboid Deformation: (A) Pressed Deformation (B) Twisted Deformation (C) Bend Deformation . . . . .	91
6.4	Demonstration of illusion deformation in between virtual and physical world. (A) The illusion of pressing, (B) The illusion of bending, (C) The illusion of twisting, (D) The illusion of squeezing. . . . .	92
7.1	Development History . . . . .	98
7.2	Six emotional tail movements display with the prototype. . . . .	99
7.3	Sketch of Tail . . . . .	100
7.4	Continuum Design . . . . .	101
7.5	The emotions designed for the virtual avatar . . . . .	102
7.6	International MCN electrode system. Looxid Link is able to extract AF3, AF4, AF7, AF8, FP1, FP2 electrodes. . . . .	105
7.7	EEG average power spectrum for 10 participant during eyes- open without performing task (EO w/o task, blue line), two- dimensional scree (2DS, green line) and virtual 3D scene (V3S, red line) in the AF3, AF4, AF7, AF8, FP1 and FP2 channels. Blue shade = Delta (1-4 Hz), Yellow shade = Theta (4-8 Hz), Gray shade = Alpha (8-12 Hz), Green shade = Beta (12-30 Hz) and Pink shade = Gamma (30-45 Hz). . . . .	109



# List of Tables

4.1	Comparison of Bare-Hand and Hand-Worn Device . . . . .	45
4.2	Description of Hand-worn types of Glove . . . . .	46
5.1	Participant's completion time in FSP . . . . .	74
5.2	Data for the complete time in Surroundingness (360°) test . .	74
5.3	Multiple Comparisons in first scene . . . . .	75
5.4	Multiple Comparisons in second scene . . . . .	76
7.1	Investigation Result . . . . .	100
7.2	Result of the Questionnaire . . . . .	106
7.3	Alpha & Theta Power in six EEG sites for the three conditions.	107

# Contents

<b>Abstract</b>	<b>I</b>
<b>Acknowledgment</b>	<b>III</b>
<b>List of Figures</b>	<b>V</b>
<b>List of Tables</b>	<b>VII</b>
<b>Contents</b>	<b>VIII</b>
<b>Chapter 1 Introduction</b>	<b>2</b>
1.1 Overview . . . . .	2
1.2 Types of Interface and Interaction Task in VR . . . . .	4
1.3 Types of Interface for VR . . . . .	4
1.4 Interaction Task in VR . . . . .	6
1.4.1 Haptic Feedback in VR . . . . .	7
1.4.2 The Communication in VR . . . . .	7
1.5 Research Questions . . . . .	8
1.6 The Definition of Immersiveness and Intuitiveness in VR . . . . .	9
1.6.1 Traditional Definition . . . . .	10
1.6.2 Modern Definition . . . . .	10
1.6.3 Our Definition . . . . .	10
1.7 Aims and Objects . . . . .	11
1.8 Dissertation Outline . . . . .	12
1.9 Novelty . . . . .	15
1.10 Significance of this research in Knowledge Science Scope . . . . .	16
<b>Chapter 2 Literature Review</b>	<b>19</b>
2.1 Capture the Real World: Tracking Technology . . . . .	20
2.1.1 Camera-based Tracking . . . . .	20
2.1.2 IMU Motion Tracking . . . . .	21
2.1.3 Infrared Motion Tracking . . . . .	22
2.2 From Real to Virtual: Input Devices . . . . .	22

2.2.1	Hand-Held Input Devices . . . . .	23
2.2.2	Hand-Worn Input Devices . . . . .	24
2.3	Impression to Perception: Affective Computing . . . . .	25
2.3.1	Intuitive and Immersive Feedback from Human Perception . . . . .	25
2.3.2	Spatial Presence in Intuitive and Immersive Interactions	27
2.3.3	Intuitive and Immersive Feedback Analytics with EEG signal . . . . .	27
2.3.4	Haptic Feedback . . . . .	28
2.4	Bidirectional relationship between Virtual and Reality: Digital Twins . . . . .	29
<b>Chapter 3 Methodology</b>		<b>32</b>
3.1	Research Design . . . . .	32
3.2	Methods . . . . .	34
3.2.1	Gestures for VR with gloves and motion tracking device	35
3.2.2	Passive haptic feedback for VR . . . . .	36
3.2.3	Double-bridge avatar in VW and PW . . . . .	37
<b>Chapter 4 Motion Tracking And Hand Manipulation</b>		<b>39</b>
4.1	Introduction . . . . .	39
4.2	System Overview . . . . .	41
4.3	Design of the wearable IMU motion tracking device . . . . .	41
4.3.1	Device Implementation . . . . .	42
4.3.2	Software Architecture . . . . .	42
4.4	Design of the VR Glove . . . . .	43
4.4.1	Hardware Architecture . . . . .	46
4.4.2	Software Architecture . . . . .	48
4.5	Wireless Data Transmission . . . . .	48
4.6	Persistent Gesture Recognition . . . . .	51
4.6.1	Implementing method . . . . .	52
4.7	Experiment and Results . . . . .	55
4.8	Conclusion and Discussion . . . . .	56
<b>Chapter 5 Comparison of the Intuitive and Immersive Feeling with Existed VR Input Devices</b>		<b>59</b>
5.1	Introduction . . . . .	59
5.2	Research Method . . . . .	61
5.3	Scenarios Design . . . . .	62
5.3.1	VR cup stacking game design for Subjective Experiment	62
5.3.2	Scenario of EEG Experiment . . . . .	65

5.4	Device Setup . . . . .	65
5.5	Intuition Experiment Design . . . . .	68
5.5.1	Participants . . . . .	68
5.5.2	Procedure . . . . .	68
5.5.3	Experiment Design For Questionnaire . . . . .	69
5.5.4	EEG-based Evaluation Design . . . . .	70
5.6	Results . . . . .	73
5.6.1	State of Presence Experiment Results . . . . .	73
5.6.2	Questionnaire Results . . . . .	74
5.6.3	Result of Analyzing user EEG signal . . . . .	78
5.7	Discussion . . . . .	79
5.7.1	Device Learnability . . . . .	79
5.7.2	Device Effectiveness . . . . .	80
5.7.3	Device Extensibility . . . . .	81
5.7.4	Discussion of the EEG analyzing result . . . . .	81
5.8	Conclusion . . . . .	82
<b>Chapter 6 Implementation of Interactive Mesh Deformation in between the Virtual and Physical World.</b>		<b>84</b>
6.1	Introduction . . . . .	84
6.2	Mesh Deformation Implementation . . . . .	85
6.2.1	Force Direction . . . . .	86
6.2.2	Stay in Shape . . . . .	88
6.2.3	Bend and Twist Deformation Implementation . . . . .	89
6.3	Applications . . . . .	91
6.4	Conclusion . . . . .	91
<b>Chapter 7 VR Integrate with Companion Doll</b>		<b>94</b>
7.1	Introduction . . . . .	94
7.2	The processs of designing BOBO . . . . .	96
7.2.1	Motor-Driven based Tail Mechanism . . . . .	96
7.2.2	Tail Movements and Emotion feedback of BOBO . . . . .	100
7.3	Experiment Design . . . . .	103
7.3.1	Questionnaire Overview . . . . .	103
7.3.2	Evaluating User Cognition in an Interaction with Vir- tual & Physical Doll Using EEG . . . . .	104
7.4	Results . . . . .	106
7.5	Conclusion and Discussion . . . . .	107
<b>Chapter 8 Conclusion and Future Work</b>		<b>110</b>
8.1	Conclusion . . . . .	110

8.2	Contribution for Knowledge Science . . . . .	115
8.3	Limitations . . . . .	116
8.4	Future Work . . . . .	118
	<b>References</b>	<b>119</b>
	<b>Publications</b>	<b>139</b>

# Chapter 1

## Introduction

### 1.1 Overview

Human-Computer Interaction (HCI) serves as a conduit for information exchange between users and the digital world. The user interface functions as the bridge for transmitting and exchanging information, ideally achieving intuitive manipulation that allows for the seamless integration of the physical world (PW) and virtual world (VW), regardless of time and location [1]. However, the realization of this ideal has been hindered by technical limitations. Therefore, the goal of HCI design is to convert user input and output into representations that can be understood by both humans and computers. This is achieved through the use of appropriate metaphors and feedback provided to users through the interface, that can influence user behavior and state.

In recent years, Virtual Reality (VR) has been considered as a novel HCI approach. VR requires processing input information from multiple sensory channels, such as muscle extension, posture, language, and body tracking, to closely simulate the realistic feeling of the real world [2]. VR can also rapidly provide real-time sensory information that can be experienced by the eyes, ears, and body according to the user's viewpoint changes and different input utilities.

This type of HCI can provide user with an imersive experience. These features of immersion experience are as following: (1) feedback could be visual, auditory, or physical, and is provided through techniques such as visual effects and actuators [3]. (2) Adaptability refers to the consistency of feedback and the look-and-feel of virtual objects, which should respond appropriately to user interactions [4]. (3) Envelopment refers to the degree to which the virtual scenario surrounds the user, and can be achieved through technologies such as 360-degree views, surround sound, and gesture and motion tracking [5]. (4) Vividness refers to the quality of feedback that virtual scenes and avatars can simulate, including sound reflections, physical responses, and high frame rates [6]. (5) Interactivity is the effect of users

changing virtual content or virtual content changing user perception through specially designed software and hardware interfaces [7]. (6) Storytelling is the consistent narrative of information or experience, the dynamic development of events, and the overall worldview that matches the user's perception of the virtual content [8]. Therefore, developers must strike a balance between objective and subjective elements to ensure that the immersive experience is well-received by society and the public.

Two-way perception between the user and the virtual environment is crucial for creating a natural and immersive experience. With the purpose of creating a harmonious human-computer environment, interactive devices are normally used in VR experience to enable the computer to generate natural and straightforward interactivity with virtual objects.

Among the different types of VR-based interactive devices, wearable devices and companion robot has been increasingly used in the virtual experiences

Virtual reality (VR) technology has revolutionized the way we experience digital content. With the advent of wearable devices and companion robots, the immersive experience of VR has become even more engaging and realistic.

Wearable devices, such as VR Glove, provide users with a fully immersive experience, where they can enter a virtual world and interact with objects and characters in real-time. These devices use sensors to track the user's hand movements, allowing them to perceive their hands within the virtual environment. This technology is particularly popular in the gaming industry, as it enables gamers to fully immerse themselves in the game world.

Companion robots, on the other hand, are physical robots that are designed to interact with users in both the physical and virtual worlds. These robots can simulate human-like emotions, providing users with a more realistic and personalized experience. For example, a companion robot could be used in healthcare to provide emotional support to patients undergoing treatment. By using VR technology, the robot could create a virtual environment that helps to distract the patient from the stress and pain of the treatment.

Overall, wearable devices and companion robots are opening up new opportunities for VR-based experiences. These technologies are not only providing users with a more immersive experience, but they are also creating new avenues for education, entertainment, and healthcare.

## 1.2 Types of Interface and Interaction Task in VR

In traditional two-dimensional (2D) user interface and interaction, graphical user interface (GUI), which widely adopts the WIMP (Window, Icon, Menu, Pointer) form, is widely used. The graphical representation of windows, icons, and menus abstracts the functions and operations of the computer. Users interact with these planar graphic contents through a mouse to achieve HCI. These graphic representations are 2D, and the user's pointing device is also constrained to implement 2D motion on the desktop surface.

In contrast to 2D interaction, VR provides a more flexible and unrestricted user experience. It allows users to move beyond the constraints of working in front of a desktop and eliminates limitations imposed by desktop surfaces. In the VR interface, the user is presented with a 3D environment that provides a more immersive and realistic experience. The input and output of the interaction between the user and the virtual environment are carried out in three-dimensional (3D) space, making 2D graphical interface components unsuitable for interaction in VR. Therefore, interaction design in VR needs to consider more natural ways, output displays, and interaction metaphors.

## 1.3 Types of Interface for VR

The dominant 2D GUI used in desktop environments supports current main applications, including web browsing, document editing, spreadsheets, application graphics, and tabletop gaming. This interface provides a fast, accurate, and stable way to interact and has been widely accepted by hundreds of millions of users [9]. However, for VR applications, this mode of interaction is inappropriate due to it is impractical for a user to wear a helmet and use a keyboard. The resolution of head-mounted displays (HMDs) is limited and is not suitable for applications that require frequent text input, such as dialog boxes. Furthermore, in VR applications, users and controllers need to be able to move anywhere in 3D space. This requires the user to continuously change their orientation, and the controllers must always appear to follow the user's hand movements. Therefore, keyboards and mouse are not suitable for interactive 3D space tasks.

The main issue with the GUI supported by the WIMP paradigm is the limited input bandwidth in the interaction. The input side is restricted to precise clicks (one pixel at a time) and discrete key signals, forming a sequen-



tial conversational interaction, which is insufficient to utilize manipulative skills acquired in real-life scenarios. In order to overcome this limitation, capacitive touch panels with force sense detection are being developed to improve the ways of 2D interaction and make the interaction process more natural. Since 1994, the smartphone, represented by a 2.5D user interface, mixed and augmented reality user interface, and multi-channel user interface, has quickly become a research hot topic.

The 2006 ACM CHI conference workshop titled "What is the Next Generation of HCI?" examined various styles of interaction technologies. In 2008, Jacob. et al, introduced the concept of reality-based interaction (RBI) [10] and attempted to utilize it as a comprehensive framework for interface design that can be composed of four levels:

**Principles of Physics:** General perception of the PW, such as gravity, friction, velocity, object presence and scaling.

**Human perception and skills:** body awareness, human proprioception of one's own body and the ability to control and coordinate limbs.

**Environmental Awareness and Skills:** Human perception of the surrounding environment, and the ability to operate and navigate in the environment.

**Social Perception and Skills:** Human perception of and ability to interact with others in the environment.

The RBI framework offers interaction designers meaningful guidance for understanding real-world metaphors for HCI, particularly in the context of VR. Unlike the typical WIMP paradigm, there is no single paradigm that dominates interactions for VR and augmented reality. This is due to the fact that the input methods used are no longer fixed, the output presented to the user is not limited to 2D images, and bidirectional perception between the user and the VR system presents multi-channel characteristics. These different channel methods for interaction can be summarized in terms of "vision, sound, speech, and haptics".

The meanings of these four methods on the user side are as follows:

**Vision:** To observe virtual scenes through eyes, including 2D images or stereoscopic display images.

**Sound:** To perceive virtual sounds effects through auditory (ear) channels.

**Speech:** The user can talk to the system by voice.

**Haptic:** The user utilizes haptic receptors to perceive the force-tactile presentation of the system.

In the VR environment, users perceptions of the environment can also be categorized into these four ways. Their meaning can be further interpreted

as follow:

**Vision:** To capture the user’s movements, actions or expressions in a non-contact way through computer vision techniques, such as gestures, postures, eye movements.

**Sound:** To capture the user’s speech using a microphone array.

**Speech:** The system asks the user for their intent.

**Haptic:** The system senses the spatial orientation or position, acceleration, touch, such as, muscle stretching and twisting, and even changes in electrical signals in cranial nerve areas, can be provided by joysticks, touch controls, data gloves, inertial tracking, etc.

The realization of these four elements is natural interaction, which is the paradigm of VR interaction. In the GUI, it is necessary to learn the use of the mouse and memorize the operational meanings represented by various icons. On the other hand, in the natural user interface, it is only necessary to interact with the machine in the interactive environment (mobile, desktop, spatial environment) in the most natural way of communication (such as eye movement, language, expression, gesture and body).

## 1.4 Interaction Task in VR

VR focuses on immersion achieved through intuitive interactivity, which is different from traditional 2D human-machine dialogue. The 3D interaction in VR enhances the user’s perception of the VE and provides intuitive interaction, which is the most important part of VR. People have acquired many skills for manipulating 3D objects and moving in 3D space in their daily life, making 3D interactive methods advantageous. The 3D interaction oriented toward the VE is, therefore, one of the focuses of VR interaction research.

Somatosensory operations combined with VR have become popular in people’s daily life, such as Nintendo’s fitness ring [11], which uses movements and equipment such as limbs and gestures for games and interaction. With the development of this technology becoming more mature, the applications of wearable sensing devices, robot interaction, and VR devices have evolved from entertainment applications to medical and educational applications. Intuitive interaction can make users feel the same sense of process in the VW as in the real world, and the sound, tactile, and visual stimuli that are directly fed back to the user after the operation can increase the user’s sense of presence in the VW.

Using realistic VR simulation, any special environment or atmosphere can

be simulated with all the parameters that consumers wish, and all the body actions of users can be tracked and visualized for an intuitive and immersive interaction interface. In the entertainment field, playing games that combine somatosensory input devices and a 360° visible headset employs the VR concept to attract and motivate people to interact with virtual content using their bodies, which can benefit people's health and quality of life, especially during the pandemic period.

### **1.4.1 Haptic Feedback in VR**

VR technology has revolutionized the way we interact with digital content. By simulating real objects in VE, users can have an immersive experience, which can be achieved by using sensory cues. These cues include visual, auditory and, tactile feedback, enabling users to feel and interact with virtual objects and environments.

Among them, tactile feedback [12] is a kind of change such as vibration, pressure and, temperature generated by handheld input devices, wearable devices and other devices that provides important feedback for user interaction in VE, such as when they touch virtual objects in VR games or feedback when monsters hit. This provides users with a more realistic and immersive VR experience.

In VR systems, passive haptic feedback and active haptic feedback are commonly used. Passive haptic feedback [13] is tactile feedback that occurs naturally when a user interacts with a virtual object. For example, if a user's virtual hand touches a virtual wall, the user will feel the resistance of the wall through the VR controllers or gloves they are wearing. On the other hand, active haptic feedback [14] is provided to the user through an external device. This type of feedback is used to simulate specific physical feedback on the VE. For example, when a user is playing a VR fishing game, the brake installed on the fishing rod can provide pulling feedback.

Overall, haptic feedback is an important part of modern VR systems as it enables users to interact with virtual environments (VE) in a more natural and intuitive way. By providing realistic and immersive tactile feedback, VR technology is changing the way we experience the digital environment, and its application possibilities in various fields are endless.

### **1.4.2 The Communcation in VR**

In general, VR communication [15] can be described as an interaction between humans and objects or other humans in a digital world. It is related to the design of the relationship between users and the content. Although

VR communication is an abstract concept, it can be divided into direct communication and indirect communication.

### **Direct Communication**

In the PW, direct communication refers to the transmission of energy between entities without the intervention of any medium. However, in VR, direct communication requires the establishment of an interface between the user and the virtual content to provide stimuli, such as shapes, motions, and haptics. The interface needs to be designed in such a way that it is imperceptible to the user. When the user perceives the interaction and feedback from the virtual content as they would in the physical world, it enhances the immersive and intuitive experience.

### **Indirect Communication**

Indirect communication is the process of conveying meaning through behavior or action, without the use of direct energy transfer. It involves the interpretation of events and reactions to them. In VR, indirect communication is achieved through various methods, such as using gestures to modify the state of objects or triggering events by selecting a panel. It is essential to design interfaces that allow users to understand the meaning behind their actions, leading to an immersive and intuitive experience. Through indirect communication, users can interact with virtual environments in a natural and intuitive way, and the possibilities for its application in various fields are endless.

## **1.5 Research Questions**

While VR technology has made significant advancements in recent years, there are still exist several limitations that must be addressed to create intuitive and immersive VR interactions. Some users may experience discomfort or difficulty interacting with virtual objects, particularly when there is a mismatch between physical movement and visual feedback in the VE [16]. This is a major issue that reduces the intuitive and immersive experience for users while using VR applications.

To address this main research question, we have divided our research into four sub-research questions (SRQs).

## Sub-research Questions

Many current VR input devices may require users to perform unnatural interactions that do not feel intuitive, particularly handheld controllers that need to be tracked by cameras. This leads to a limited range of motion and makes it difficult to perform natural actions or movements, causing users to experience fatigue or discomfort [17].

Without familiar gestures and movements in virtual environments, users may find it difficult to understand and control their interactions with virtual objects [18]. Pressing a button to grab a virtual object betrays their existing knowledge and muscle memory, increasing the gap between the PW and the VW.

If the interaction does not provide passive haptic feedback to users, they may feel unrealistic while interacting with virtual objects that do not offer any object deformation or feeling of weight, similar to interacting with air [19]. Abandoning users' ability to sense feelings could provide a bad intuitive and immersive experience.

One of the significant advantages of VR is that it provides a connection between the PW and the VW.

A double-bridge avatar is a concept in virtual worlds that refers to an avatar that is simultaneously controlled by the user in two different environments, typically one in the physical world and the other in the virtual world [20]. Without a double-bridge avatar, users may not have a feeling of body awareness and lack intuitive interaction due to the absence of any virtual avatar [21] to extend the visual and physical haptic feedback between the PW and the VW.

We simplify each SRQs as follow:

**SRQ 1** How to achieve the intuitive manipulation?

**SRQ 2** How to bring daily-life gestures interaction to achieve immersive experience in VW?

**SRQ 3** How to provide passive haptic feedback for VR?

**SRQ 4** How to provide the interaction experience through bidirectional relationships for VR through the concept of double-bridge avatar?

## 1.6 The Definition of Immersiveness and Intuitiveness in VR

The questions mentioned above surround the intuitive and immersive experience. However, those experiences have a little bit different meaning before

and after VR technology comes out. So, we divide it into traditional, modern definitions and our definition of intuitiveness, and immersiveness as follows:

### 1.6.1 Traditional Definition

The traditional definition of immersive experience focuses on creating the feeling of being present or "being there," in a VE [22]. This can be achieved through technologies such as spatial projection technology or 3D audio, which create spatial presence and interaction. It can also be achieved through other means, such as storytelling, narration, or other forms of engagement that create emotional connections between users and systems.

### 1.6.2 Modern Definition

Nowadays, due to the the widespread use of VR in various fields, providing intuitive and immersive experiences is essential [15]. Intuitive manipulation allows users to navigate through VE and interact with virtual objects without too much thinking. It makes the experience more natural and enjoyable. Immersiveness, on the other hand, creates a sense of presence and allows users to feel like they are there, making the experience more engaging and memorable.

### 1.6.3 Our Definition

Based on traditional and modern definitions of immersion and intuition, we propose a hypothetical theoretical model through which four elements can gradually enhance the user's intuitive and immersive experience in VR. We call it the NHED theoretical model, and each element is explained as follows:

**Natural interactions:** As in VR, it can be explained by creating an immersive environment that mimics the natural world [3]. Therefore, this study hypothesized that this might involve creating gestures and feedback that users can explore and interact with. Users can grasp objects with their fingers, or see objects deform as if they were real changes, which can enhance immersion and intuitive interaction at the level of physical perception.

**Human Factor Feedback:** As human factor feedback can allow users to interact more intuitively with virtual environments [23], this study believes that providing gesture controls that align with users' everyday behaviors, or feeling tangible objects deform within the virtual environment, can enable users to interact with it in a natural and intuitive way.

**Embodiment Sensation:** As embodiment can enhance the homogeneity of virtual and real objects in VR [24], this study believes that providing users with the ability to perform virtual operations using only their hands, and consistent feedback on the changes of virtual and real objects, can provide a more intuitive and engaging experience, making it easier for users to understand and interact with.

**Double-bridge Avatar:** As bidirectional embodiment can achieve a two-way experience in the interaction process [25], this study believes that providing users with bidirectional carriers for interaction between virtual and real environments can enhance the sense of immersion and presence in the virtual environment, achieving a two-way overall experience.

## 1.7 Aims and Objects

The purpose of this research is to increase immersive experience in VR technology with respect to the logic sequence of this research shown in figure 1.1. Through reviewing the background, we address four gaps which include the current intuitive interaction, gesture interaction, passive haptic gap in VR, and the practical application that can represent the concept of digital twins. These four gaps can all be directed in one question "How to achieve intuitive and immersive experience in VR?" Therefore, the aims and objectives of this research have four parts, aiming to enhance the interaction experience with hardware in VR.

First, the current commercial input device is not suitable for human natural behavior during VR experience. Free hand manipulation which is close to natural behavior in daily activities. To address the problem, a motion tracking device is developed for detecting the forearm swinging pattern, and a new type VR glove is developed to simulate the user's hands in the VE.

Second, existing gesture recognition usually only recognizes static gestures. However, continuous gestures are the most performed by humans in physical movements. To address the problem, through the data from our proposed devices, an algorithm is carried out for recognition of continuing gestures and its validity. Finally, we adopt a repeated test to evaluate the effectiveness of the continues gesture recognition method. For evaluation, we conduct a series of experiments which include comparison of operation time, questionnaire of the experience, and analytics of the user's EEG signal.

Third, in the existing research results, physical devices cannot fully realize composite simulation from physical deformation to virtual simulation. To address the problem, we add pressure sensors on our VR glove to

receive the pressure from finger tips while user is adding force to a physical object, meanwhile we propose an algorithm to simulate the corresponding deformation on the virtual object to provide passive haptic feedback to users.

In the last part, most of the work developed for the interactive companion doll only provides one-way feedback in the PW. To address the problem, this work develops a new type of interactive tail robot, which can provide bidirectional feedback between the PW and the VW. Finally, we design an intuitiveness and interactiveness questionnaire for the user to collect their feedback after the experiment.

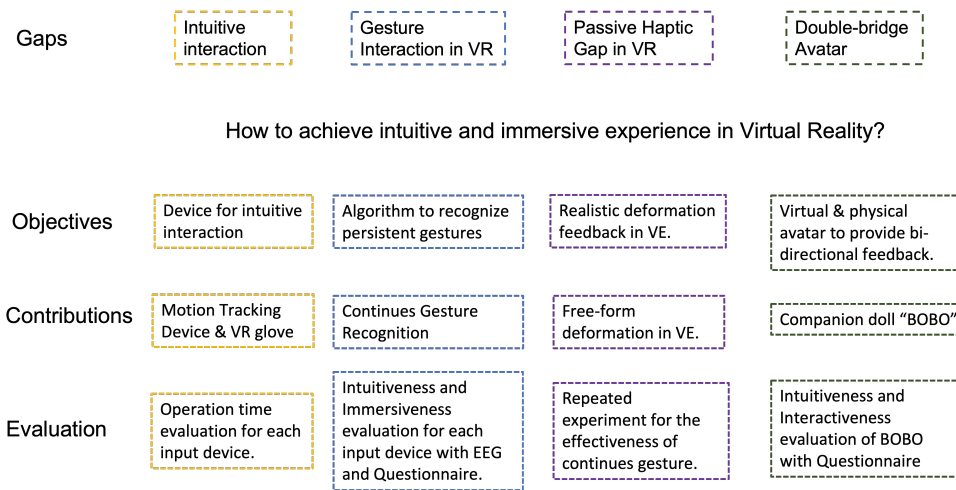

Figure 1.1: Research Logic Sequence

## 1.8 Dissertation Outline

VR technology has become increasingly popular in recent years, with applications ranging from entertainment to education and healthcare. However, the intuitive and immersive interaction with virtual objects and environments is still a challenge for current VR systems. This dissertation aims to explore the use of daily-life gestures and passive haptic feedback, along with a double-bridge avatar, to provide the intuitive and immersive interaction in VR. The research question is: How can the incorporation of daily-life gestures, passive haptic feedback, and a double-bridge avatar improve intuitive and immersive interaction in VR? In this dissertation, we first explain briefly of the background and the questions we are addressing for, then review the



existing literature on VR interaction and the use of daily-life gestures and passive haptic feedback. Next, we describe the methodology used to conduct the research and present the results of our experiments. Finally, we conclude with a summary of the main points and arguments presented in the paper, and their significance for the field of VR. The roadmap of this research outline is shown in figure 1.2.

This research had been used 7 chapters within the main body of the dissertation, as follows:

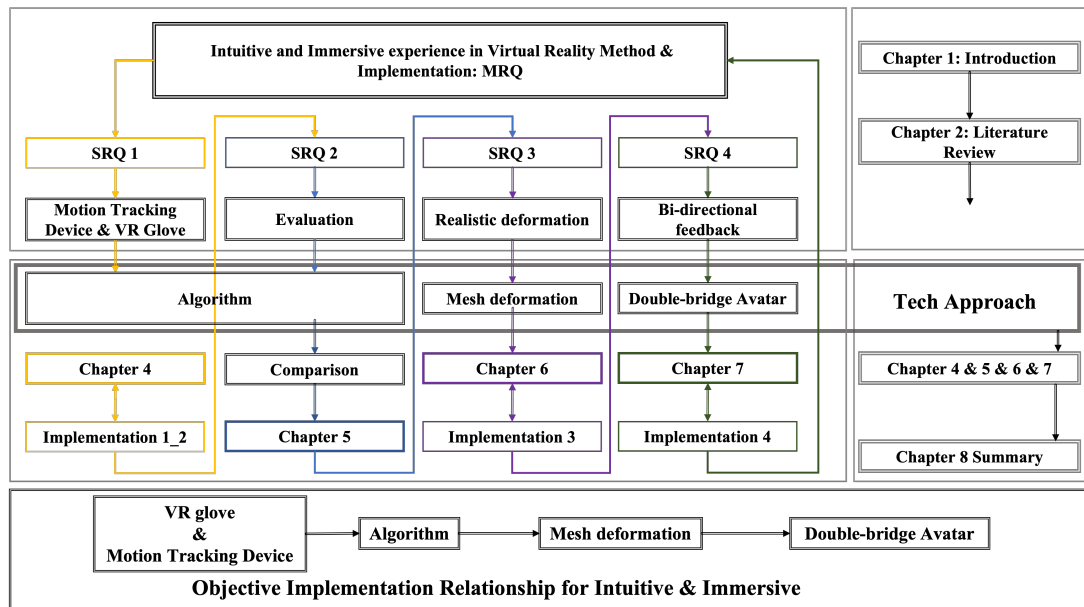

Figure 1.2: Research Outline

## Chapter 1

Chapter 1, Introduction provides an overview of VR including brief background description, different types of interface and interaction of VR, including statement of the research questions of existing VR interaction development. Then we explain briefly our proposed methods of how to overcome these challenges and explain its novelty. Lastly, there are several crucial ideas that will be discussed in greater depth in subsequent chapters.

## **Chapter 2**

This chapter summarize the existing research and literature related to the elements that require the development of a immersive and intuitive VR application. First, we introduce VR tracking technology and the types of VR input device. Then, review the topic of affective computing related works from intuition and immersion feedback and types of haptic feedback. Finally, we discuss the immersion and intuition interaction in a bidirectional relationship between virtual and reality.

## **Chapter 3**

The chapter of methodology outline the designs and methods used to conduct this research. This chapter specifically describes the thinking process and establishes the solutions for MRQ and its divided SRQs. And give an briefly introduction of each research methods.

## **Chapter 4**

In chapter 4. The work has developed a wearable device for motion tracking and a VR glove that can provide intuitive gesture behavior.

In addition to that, the algorithm proposed in this chapter can recognize the continuous gesture as in the real world. By inserting the recognition result of each static gesture into a sequence that is updated in real time, when the correct result in the sequence reaches a certain threshold, the purpose of recognizing continuous gestures can be achieved.

Finally, we conducted a series of experiments to reveal the recognition rate for each combination of gestures.

Through our proposed device and recognition method, we can improve the intuitive interaction experience for VR application.

## **Chapter 5**

The purpose of Chapter 5 is to investigate user immersion and intuitive feedback by comparing different types of VR input devices. In this chapter, we designed two kinds of applications, namely the stacking cup game and the conversion of commonly used 2D gestures (grab, zoom, rotate) into gestures that can be executed in the VR environment. Questionnaires were then designed and users' electroencephalogram (EEG) signals were acquired to investigate participants' perceptions of system usage. Through statistical analysis, the level of preference and intuition offered by the different devices was assessed.

## **Chapter 6**

In chapter 6, this work proposes a method which can be simulated passive haptic feedback. Transform the vertex coordinates from virtual objects through a series of linear equations which are used in virtual scenes to simulate the deformation of objects bent, twisted, and pressed. The method can provide a sense of touch and interrelated deformation with a decrease in the development cost.

## **Chapter 7**

In chapter 7, this work provides a solution for delivering bi-directional feedback between the VW and the PW. First, this work develops a motor-driven tail mechanism mockup with three emotional movements (Happiness, Sadness, and Anger). Secondary, depending on the device and the VR glove. This work will build an extension of the VR application which can achieve the immersive and intuitive experience.

## **Chapter 8**

Chapter 8 gives the conclusion and the direction for future work. Furthermore, this chapter summarizes the contributions of VR intuition and immersion topics and knowledge science.

The limitations of each device and system proposed in this research are also indicated in this chapter. The purpose of this study is to improve the user experience of VR by enhancing intuitive interaction and emotional feedback. The objective of this research is to enhance the experience of interaction with hardware in VR. The aim of this dissertation is to present the VR glove and companion doll that contain improvements and development to increase presence for users during the VR experience.

## **1.9 Novelty**

The novelty of this research lies in the integration of four specific techniques: motion tracking device, VR glove, daily-life gestures, passive haptic feedback, and a double-bridge avatar to improve the intuitive and immersive interaction in VR. While each of these techniques has been studied separately in the past, this research proposes a novel approach by integrating them into a single system. This approach could potentially offer a more effective solution to the current limitations in VR interaction.

Furthermore, the proposed techniques address specific challenges in VR interaction. Motion tracking devices and VR gloves to recognize daily-life gestures can make interactions more intuitive and natural, while passive haptic feedback can provide a more immersive experience by creating a sense of physical presence in virtual environments. A double-bridge avatar can help to increase user identification and embodiment, which is essential for creating a sense of presence in VE.

Overall, the proposed integration of these devices and techniques in a single system offers a novel approach to improving intuitive and immersive interaction in VR, which has not been extensively explored in previous research.

## **1.10 Significance of this research in Knowledge Science Scope**

Knowledge science involves the study of how humans acquire, represent, and use knowledge, as well as how technology can support and enhance human knowledge-related activities [26]. The four technologies of Nature interaction, Human factors feedback, Embodiment sensation, and Double-bridge avatar are circulating because they have the potential to enhance the intuitive and immersive interaction in VR, leading to more effective learning experiences as shown in figure 1.3. These technologies in this study, have been proposed as important factors in improving VR interaction by providing a more natural and intuitive interface, feedback on user behavior and system performance, a sense of presence and agency in the virtual environment, and a bridge between the physical and virtual worlds.

Natural interaction in VR can facilitate the acquisition of both implicit and explicit knowledge, such as intuitive understanding of the natural world or explicit knowledge about environmental impacts. Similarly, human factors feedback can provide both implicit and explicit knowledge about user behavior and system performance.

Furthermore, embodiment sensation in VR can facilitate both implicit and explicit knowledge, such as a sense of presence and agency in the virtual environment or explicit knowledge about mind-body relationships. Similarly, the double-bridge avatar can facilitate both implicit and explicit knowledge about human social interactions and behaviors.

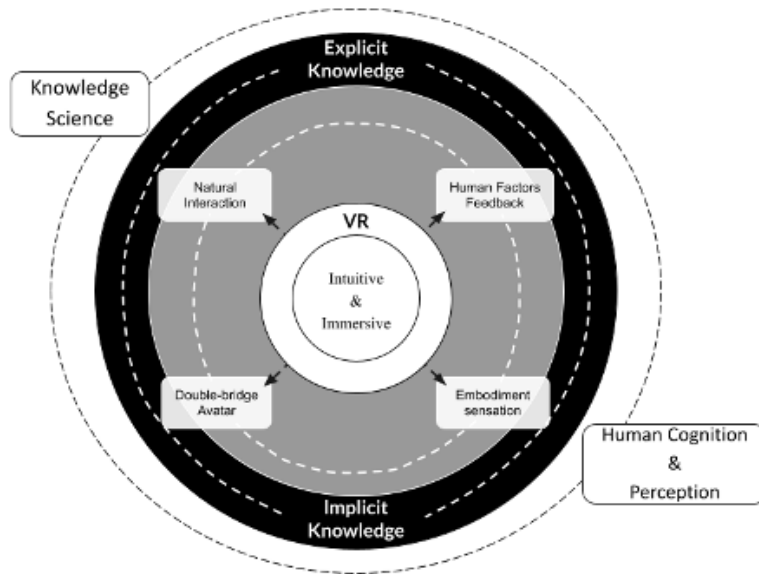

Figure 1.3: NHED model in knowledge Science

It is important to note that these technologies can facilitate both implicit and explicit knowledge depending on how they are used. For example, natural interaction can facilitate both implicit and explicit knowledge depending on whether it involves acquiring knowledge about the natural world or developing an intuitive sense of how to interact with the system. Similarly, embodiment sensation can facilitate both implicit and explicit knowledge depending on whether it involves acquiring knowledge about mind-body relationships or developing an intuitive sense of how to interact with the virtual environment.

Furthermore, the incorporation of motion tracking devices, VR gloves, daily-life gestures, passive haptic feedback, and a double-bridge avatar in VR has the potential to overcome some of the limitations of traditional VR interactions and enhance the intuitive and immersive interaction in VR. This could have significant implications for knowledge-related activities, such as training and education, where immersive and interactive environments can provide more effective learning experiences.

Overall, the significance of this research lies in its potential to enhance the design and development of technology that supports and enhances human knowledge-related activities, which is one of the significant approaches to human cognition and perception for VR interaction in a knowledge science perspective. Additionally, Knowledge Science and Human Cognition & perception are related fields that contribute to the understanding of how

humans acquire and use knowledge, and how technology can support and enhance human knowledge-related activities. The placement of these terms on the left and right side is arbitrary and does not reflect any opposition between the two concepts.

# Chapter 2

## Literature Review

An optimal VR interface would enable users to freely move within a VE and interact with virtual objects in a way that mimics real-world experiences.

Ivan Sutherland, the inventor of the first VR head mounted display system [27], proposed that the ideal VR interface would be a room where computers can manipulate matter. In such a room, virtual objects would have the same properties and reactions as real objects. For example, a chair would be comfortable to sit on, handcuffs would feel confining, and a virtual bullet would have the same fatal impact as a real one.

Unlike the typical HCI such as Console Games. Schuemie's research [2], VR technology aims to create an immersive experience for users that projects stimuli in a comprehensive, matching, surrounding, vivid, interactive, and plot-informing way. The level of immersion experienced by users is the degree to which the VR system and application successfully project stimuli onto their sensory receptors.

To provide immersive visual content, if the visual experience with large screens is not enough, there are various stereoscopic display systems available for use, such as HoloLens 2 (Dorin et al. 2020) [28], projection-like CAVE (Skevi et al.) [29] and Head Mounted Display (HTC Vive, Quest).

The other essential element is pose tracking technology; it detects the exact position of displays mounted on the head, input devices, other objects, or other parts of the body in euclidean space with different types of tracking technology such as camera-based tracking, inertial sensor tracking, and infrared (IR) tracking.

Regarding the input devices, it help users navigate and interact with VR environments and can be divided into two types, handheld device ( joysticks, track pads, and buttons) and hand-worn device (data gloves, arm bands).

Input device normally provide haptic feedback that allows the user to touch and feel something in the VE that simulated a similar feeling as in the real world.

To verify the intuitiveness and immersiveness of different types of input device, this chapter reviews several studies related to the intuition experiment, spatial presence experiment, and analytic of the user's EEG signal

experiment.

Furthermore, communication typically refers to the exchange or transfer of information or ideas between two or more entities. It can also be stated that the transfer between humans and technologies is an important component and foundation of VR.

Digital twins based on companion dolls are focused on the communication of how VW controlling the world and objects, and content-user relationships between the VW and PW.

## **2.1 Capture the Real World: Tracking Technology**

A well-designed VR experience can be seen as a collaboration between humans and machines, and software and hardware work in harmony to provide intuitive communication with humans [30].

”Disintermediation” represents an ideal design of intuitive interaction, which means the manipulations in everyday life without awareness of conventional input devices.

Obviously, conventional computing modules using unnatural input devices such as keyboards and joysticks cannot achieve this goal.

To implement natural interaction, tracking technology becomes the core of human-computer interaction in the context of VR. Based on the different tracking system, the system can be divided as follows.

### **2.1.1 Camera-based Tracking**

Camera-based tracking uses cameras to setup on the HMDs or placed around users to track position and orientation, the same concept of stereoscopic human vision.

For camera-based tracking methods, the most widely used product is Microsoft’s Kinect (Zhang 2012) [31]. After its release, there have been more and more researches on somatosensory operation combined with VR based on the Kinect. Because of its depth image information, Kinect’s infrared depth image is different from the previous body recognition technology that mainly used RGB image as the main identification method. The light source requirements for the environment are relatively low, and Microsoft provides Windows SDK and a large number of technical documents so that ordinary developers can quickly grasp the human skeleton through related resources, making this device invest more in related research on



somatosensory operations. For the tracking of gestures (Xi et al 2018) [32], they set the Kinect close to the palm, and the depth image was used to first locate the hand position, and then develop it through related image processing algorithms to track the user’s gesture in real-time. However, the Kinect needs to be fixed in front of the user, so the movement of the character is limited by the camera’s field of view.

As for the device directly installed on the VR HMDs, Leap Motion is one of the popular products of VR combined with gesture control in recent years because it can easily place the device in front of the helmet. Leap Motion brings gesture tracking technology to mobile VR (Vasylevska et al. 2017) [33], which means users can grab virtual objects without using controllers and interact with the virtual contents without any restriction (for example, users no need to wear gloves or setup any sensors/ mechanisms on the wrists or palms).

Another popular product is Intel’s RealSense due to its dual camera interface for calculating real-time depth images and high-end IC for accelerating the speed of computation, a set of image sensors that can capture images at resolutions up to 1280 x 720, an infrared projector that emits light onto objects to improve the accuracy of depth data., and a dedicated color image signal processor for image adjustment and scaling of color data [34]. And for VR applications Anna Henson et al [35] using HTC Vive, Vive tracker and the participant’s eyes placed in the headset positioned Intel RealSense depth camera, builds a dancing scene in Unity 3D, and uses custom algorithms to stream and render high-resolution volumetric video (synchronized depth + RGB color feedbacks) of both physical and virtual dancers in real time. Immerse participants in a VE and use voice commands and body movements to facilitate participant interactions with virtual and tangible objects as dancers in that space.

These camera-based methods of tracking help us explore research into embodied interactions, kinesthetic awareness in mediated experiences, trust and emotion in co-presented XR experiences, and the ever-changing boundaries between physical and digital.

### **2.1.2 IMU Motion Tracking**

IMU motion tracking was implemented by acquiring the data from accelerometers, gyroscopes and magnetometers. The displacement from the initial point to the current position can be calculated by two times integrating the linear acceleration data gained from the accelerometer.

A gyroscope is used to measure the angular velocity, which can be integrated to obtain the displacement from the initial point to the current

position.

Magnetometers are used to read uniform magnetic field vectors and can be used as a good reference for calibrating low cost gyroscopes to obtain absolute orientation data [36].

Developed in recent years with the maturity of microelectromechanical systems (MEMS)-based IMU technology, these remarkable miniature sensors allow developers to derive physical data, and is a key technology in the design of eventual wearables, which can be affordable while accurate and low-latency tracker design (Zhu et al. 2016) [37].

Some motion capture suits (Roetenberg et al 2009) [38] also uses IMU sensors which installed at each joint of the human body to obtain the data changes of human activities and synchronize them to the computer to give the character model close to anthropomorphic movements and apply it to various fields such as movies and games.

### **2.1.3 Infrared Motion Tracking**

Infrared lasers are low-cost, high-power lasers with multiple functions. These lasers are small and lightweight, allowing operation without high input power requirements.

Unlike camera-based tracking, infrared (IR) tracking is a system that can keep detecting an object's position by using IR light. IR tracking requires placing an IR receiver on the target. The IR emitter sends out a constant stream of IR light, and the receiver scans the IR stream to check the target's position. An example of an IR tracker is to track the movements of the fingers, such as Kratky [39], built a transparent touchscreen by placing the IR sensors to track the movements of the fingers of the user to interact with the digital content.

For VR tracking technology, HTC lighthouse and Vive tracker (Miguel et al. 2018) [40] both used scanning infrared laser lines to trigger small infrared sensors in the peripheral being tracked, and by comparing the time when those sensors are triggered, the angle can be derived. In turn, from enough of these angles, the position can be calculated with high accuracy and low latency.

## **2.2 From Real to Virtual: Input Devices**

An input device is a physical tool or hardware that communicates information to an application and interacts with a VE.

For the virtual content interaction and communication, input devices are the physical intermediate tools to deliver message to the application.

Different applications have varying requirements for input devices, with some applications needing more or less utility from different devices, while other tasks may require specific input devices designed with particular characteristics.

Therefore, selecting the input device most suitable for application interaction technologies is an important design decision (otherwise, developing the virtual content that best fits the input device), which can be described as content-oriented design or device-oriented design.

Human hands can be extended in VR with input devices is one of the main research topics for VR developing, and this section will focus on discussing each type of device that can be integrated into VR.

### **2.2.1 Hand-Held Input Devices**

Hand-held controllers often with buttons, triggers and joysticks.

Button and trigger control one degree of freedom (DOF) by pressing with the fingers and usually choose one of the two states (pressed or not pressed), but some buttons can adopt analog values, joystick can provide linear value to simulate game character move, the typical device such as Playstation Joystick [41].

They are often designed to change states, to select contents, or initiate actions.

Although controllers with numerous buttons can be helpful for VR interactions, they can also result in confusion and errors if the button mapping function is unclear or inconsistent.

At the beginning, many VR applications preferred the use of hand-held controllers over the traditional mouse and keyboard because they were more reliable and easy to handle. Even players have an intuitive experience of the structure of controllers. They know where the buttons are through many years of practicing and using (Young et al. 2016) [42].

If there are touch pads and joysticks on the controller, it can be more suitable for integrating with VR.

Despite it is not as pure gesture manipulation, it still can increase the immersive feeling for just seated play by placing the controllers at the approximate location in the space or holding on the hand.

However, in some particular situation, players may move his/ her eyesight to the controller or their hands, which break presence feeling and leads to motion sickness (Bozgeyikli et al. 2016) [43] (Coomer et al. 2018) [44].

Another type of hand-held device that can be tracked in space, also equipped the similar functionality of conventional game controllers such as Vive Wands have been used in VR research for decades [45].

Currently, the majority of VR interaction is carried out through these types of input devices because of their design that allows for direct mapping to hand motion.

The controller can be tracked, user's can observe its position inside VE co-located of the real hands in the PW as well as physically felt, providing proprioceptive and passive haptic feedback (Zenner et al. 2019) [19].

The virtual avatar of the controllers can also be attached labels for the representation for each action components to provide immediate instruction of their functionality for the VR content. It is the biggest advantage over traditional game controllers.

## 2.2.2 Hand-Worn Input Devices

Hand-Worn devices can be the form of glove and arm band (Benalcazar et al 2017) [46].

Glove as the VR input device has several advantages, such as it won't loss tracking due to the environment lighting and blocked by obstacles, so the hands can be comfortably moved as nature motion without concern of losing tracking (Chakraborty et al 2017) [47].

One of the critical research is the Fakespace Pinch Glove (Bowman et al 2001) [48] with full hand and finger tracking.

Their research has enabled the generation of a vast range of pinching gestures, produced through various permutations of fingers ranging from two to ten (e.g., pinching with the left thumb and the right ring finger at the same time), in addition to hand poses. This was achieved by sewing conductive cloth into the tip of each finger.

This design allows for a wide range of pinching gestures and hand poses, from two to ten fingers, to be detected. As a result, it enables various VR interactions such as selecting through a menu system, text input, and two-handed navigation.

Other type of glove operating devices such as rotary potentiometer LucidGloves [49], it consists of five potentiometers, through spools attached to each finger tips by a string. The potentiometers can be measured while user curls their fingers. Several glove input devices researches adopted piezoelectric sensors (Piskozub et al 2022) [50] and inertial motion sensors (O'Flynn et al 2015) [51]. However, these types require high expense or a bulky size with additional sensors. Compared with these works, we select the flex sensor and pressure sensor, which is included in the glove, for sensing.

## 2.3 Impression to Perception: Affective Computing

Intuition is an unconscious process and is difficult to verbalize to people. In the research by Brandenburg et al. [52], we realize that the concept of intuitive interaction is based on experience and can be observed by how people act with kitchenware or other objects in daily life.

In most VR interaction cases, intuitive manipulation is faster than the conscious-thought mode [53].

Therefore, people intuitively use manipulation in situations they have often encountered before. Based on this understanding, we define intuitive interaction as follows: Intuition is a cognitive process, a behavior that can be learned from experience, executed in the present moment quickly and unconsciously, and difficult to describe in words.

Individuals might not be able to provide a clear explanation of how they arrive at decisions during intuitive interactions [54].

### 2.3.1 Intuitive and Immersive Feedback from Human Perception

Intuition experiments have been proposed in the field of human-computer interaction as a way to test intuitive operation.

Stefan Brandenburg and Katharina Sachse [52] designed an experimental environment in which they made a multitouch desktop (the GUI screen size is approximately 80 cm x 105 cm). The interface consists of a work area, a text description area, a start button, and three task objects on the right side of the work area. The task of the experiment was for the participants to perform three different actions (rotation, shearing, and scaling) on the object through gestures. The participants were tested twice, and two measures were used to evaluate their performance: time to first click (TFC) and total task time (TTT). TFC refers to the time between pressing the start button and starting the gesture, while TTT measures the total time taken to complete the gesture task.

The data showed that over time and with experience, subjects became faster in terms of the time required to perform gestures (TTT) and their initial reaction time (TFC).

In one of Alethea L's experiments [53], they were asked to perform two actions. The first action is to use the camera's zoom function to take a picture in autofocus mode.

The second action is to find and delete the just taken photo. Searches for the specified image stored in the camera and zooms in on it.

The results showed that participants who used similar functional products could complete the operation faster and more intuitively.

The intuitive first-use results of the product are significant because, in the case of the first operation, the participants did not know where the specified function was, but they completed the task correctly in the first exploration.

These are not physical affordances and, in most cases, are characteristics that are difficult to predict.

So participants can only act on similar features they have manipulated in the past.

Therefore, their results support the idea that having a similar action or the text description can well explain the feature of the product is more intuitive for people to use it for the first time.

Despina Michael-Grigoriou, Panayiotis Yiannakou, and Maria Christofi [55] conducted a study between groups with 22 participants equally divided into two groups.

Participants in the first "VR group" explored the skeletal system through VR gesture manipulation.

In contrast, the second "SP group" (slide show presentation) explored the human anatomy through a slide show presentation.

The above two methods can find the same information.

Before the experiment, both groups of participants completed a knowledge questionnaire (pre-KT) with a total score of 10. After the experiment, they completed the same knowledge questionnaire (post-KT).

Furthermore, they gave participants in the VR group another questionnaire (5-point Likert scale) after the experiment, which was used to evaluate hand motion recognition techniques. From the results of their research in the first questionnaire, it can be seen from the data analysis of pre-KT and post-KT that VR technology has advantages over the slide presentation method.

In the second questionnaire, participants in the VR group gave very high scores for the sense of immersion brought about by gesture operation, the cognitive sense of the system, and the ease of operation.

To study intuitive interactions in mixed reality game systems, the research from Shital Desai et al [56] conducted an experiment in which 42 children aged 5 to 12 years were invited to play a mixed reality game system called Osmo from Tangible Play. The researchers conducted a Friedman test to analyze if there were any significant differences in the frequency of intuitive, non-intuitive, and partially intuitive interactions among children who played mixed-reality games. From their results, it can be concluded that intuitive

interactions have higher average rankings than non-intuitive interactions and partial intuitive interactions.

### **2.3.2 Spatial Presence in Intuitive and Immersive Interactions**

This paper considers the presence of intuitive interactions in the context of VR, Augmented Virtual (AV), and MR. Martijn [57], mentioned that presence refers to the feeling of "being in" a world, the process of when one environment (VE) begins to overlap another (real environment).

In other words: presence refers to the user's distinction between RE and VE.

However, many factors affect the sense of presence, such as story presence [58], cognitive presence [59], and affective presence [60], which will affect the VR experience of the user.

Since it is beyond the scope of studies to consider all presences, this paper focuses on the relevant definitions of spatial presence and interaction with three types of input devices (button-based, hand-worn and bare-hand controllers).

### **2.3.3 Intuitive and Immersive Feedback Analytics with EEG signal**

Previous research has made efforts to categorize various stages of tasks, including setting up EEG equipment with VR headsets, Jan-Philipp Tauscher et al. [61] investigate the feasibility of combining off-the-shelf VR headsets and EEG. Their results indicate that, under certain conditions, EEG and VR can be combined without modifications. Customization of VR headsets improves the signal quality results. In addition, the displays latency is visible at the neurological level. Christoph Tremmel et al. [62] mentioned the current VR headset offers a logical, convenient, and unobtrusive framework for mounting EEG device. There are several non-invasive portable EEG products already applied to practical application, such as NeuroSky [63] that has Unity support in their SDK, able to integrate with VR projects. LooxidLink [64] a device that adds EEG to HTC Vive, Vive Pro, Vive Pro Eye, or Oculus Rift S glasses to create interactive environments using brain signals.

Emotiv [65] offers a wireless headset with 14 electrodes that can detect brain activity. It is designed for commercial use in research and provides professional-grade brain data in an easy-to-use interface. Avinash K. Singh et

al. [66] conducted research on EEG for VR gesture interactions and observed that their findings support the uncanny valley theory, which suggests that users become more sensitive to subtle errors, such as tracking errors, as the realism of their hand representation in the virtual environment increases.

About the gesture activities, Jan Rzepecki et al. [67], they focused on automatic EEG detection of user intent and improvement in interaction comfort. In particular, they tried to determine whether there was a perceptible difference in EEG signals between two gesture interaction scenarios, real-world gestures and virtual-world gestures with the environment displayed on the screen.

Other research has focused on investigating the changes in brain activity associated with changes in cognitive workload during tasks using EEG.

For example, L.I. Aftanas et al. [68], their research indicates that the blissful state can be observed while the brainwave bandwidth  $\theta$  density increases which locate frontal and middle frontal the prefrontal and posterior affinity cortex, the left prefrontal region (AF3) has a distinct "center of gravity".

Regarding the evaluation of EEG signals, Stephan Hertweck et al. [69] proposed a validation test for head-mounted displays (HMDs) used in combination with EEG signals to ensure reliable measurements. The study also highlights the potential of EEG as a biometric method to measure psychophysical effects in VR systems.

Ehm Kannegieser et al. [70] presented an experiment to record EEG data during and questionnaire data after game play indicate that increased overall brainwave bandwidth of beta and frontal theta activity may be related to immersion and intuition.

### 2.3.4 Haptic Feedback

Haptic feedback is the use of artificial forces to communicate between virtual objects and users. Typical haptic feedback is the vibration generated by an eccentric motor often equipped on mobile phones or game controllers, but haptic feedback is much more than that.

It can be classified based on their characteristics, such as being passive or active, tactile or proprioceptive, and self-grounded or world-grounded. Passive haptic systems refer to static physical objects, while active haptic systems provide physical feedback that is controlled by the computer. Tactile haptic systems provide feedback through the skin, while proprioceptive force haptic systems provide feedback through joints and muscles. Haptic systems can also be classified as self-grounded, worn by the user, or world-grounded,



attached to the real world. Additionally, many haptic systems can also serve as input devices [15].

Passive haptics are the most general form of feedbacks and more affordable solution, so this section will discuss passive haptic feedback.

Passive haptics generate a series of senses from real-world physical objects and similar objects existed in VE (Zenner et al 2020) [71]. The physical objects can be any form that can be touched such as large scale like furniture or hand-held objects like kitchenware. Passive haptics enhance the experience of presence, provide the diversity visual effects mapping of the real environment (Insko et al 2001) [72].

Creating virtual objects and environments in VR with passive haptic feedback can provide a more realistic experience for users. One of the VR applications is "The Walking Experiment and the Pit" done by UNC at Chapel Hill [73]. The research team has established the physical environment with styrofoam blocks and other real-world materials as same as the VR scene with the same size, same objects and same arrangement.

First, the user can touch different parts of the room. Then, the user will be asked to enter the second room and observed there's a pit on the floor. The pit quite catches user's concentration because before walk into the second room, everything the user touched are all physically real thus the user has the illusion that the pit is physically real as well.

While the user stepped over the virtual ledge(a narrow, flat surface that sticks out from a wall), the reaction can be observed even more shocking as there is a real ledge in same place in real environment. However, the real ledge is only a 1.5 inch gap from the ground compared to the virtual pit that is 20 feet deep.

## **2.4 Bidirectional relationship between Virtual and Reality: Digital Twins**

Apart from VR users, physical objects can also interact with the virtual world and appear as digital twins in it [74]. The parameters of these physical devices can be collected using ubiquitous sensing technologies to maintain their corresponding digital twins' state. This interdisciplinary collaboration requires expertise in various related fields, such as materials science, signal processing, IoT, and model identification . [75,76]. Conversely, after computation in the metaverse, the parameters in the virtual environment can be passed back to physical devices, thereby changing their real-world state.

However, the research focuses on creating a digital twin's avatar in the

form of a companion doll, as the development of digital twins in virtual worlds is still in its early stages.

Companion robots in the fields of social interaction and human activity recognition (HAR) is an increasingly popular approach, according to the investigation results by Anas and Wang [77].

A typical companion robot usually is a device that represents different kinds of emotions, motions, and light effects that allow people to interact as the work done by Milliez [78]. For the shape design, Bradwell et al [79] considered the companion robot to be a kind of social robot often designed congruent with animal aesthetics and behaviours [80], [81].

The system aims to create a prototype of a futuristic interactive companion robot for personal use as well as industrial purposes. Shaikh et al [82] proposed the design for a companion robot by using voice and gesture with object tracking that allows operators to interact with it.

Eleuda Nunez et al [83], developed an interactive companion doll, Pepita, a huggable robot, capable of sensing and delivering emotions through tangible gesture recognition and projected avatars.

They also conducted several experiments to evaluate the different characteristics of the form and function of this robot. By the literature review of previous studies, haptic companion doll is an increasingly popular approach in social robotics but few applications, especially for VR.

The types of social robots that have emerged can be classified into four main categories: humanoid robots that resemble human beings, animal-like robots, cartoonish robots, and functional robots designed for specific tasks [84].

It has shown that the appearance of a robot has a significant impact on how people perceive its capabilities, and may also affect their expectations of what the robot can do [85].

It is believed that each of the four categories of social robot appearance is more suitable for a specific task [86].

The humanoid robot is designed with a human-like appearance and is intended to interact with people in a manner similar to humans by using various gestures, facial expressions, and body postures. They are suitable for providing services in public places. Highly humanoid robots may trigger human-like communication, making them most suitable to investigate people's behaviours.

Designers of humanoid robots aim to develop behaviors and interactions that meet user expectations due to their human-like appearance, allowing for interesting and meaningful interactions.

The close contact between people and pets inspired the development of animal-type robots.

Their social applications and creating a sense of companionship between people and pets have a high potential [87].

In many cases, the benefits of animal robots are used, including auxiliary applications in the medical field [88].

For example, many hospitals have intervention facilities in pediatrics units, where child life specialists will provide clinical interventions to hospitalized children for developmental and coping support.

Jeong et al [89] showed that incorporating a companion doll in interventions is possible, and their findings suggest that children experience more positive emotions when interacting with their companion dolls.

Regarding appearance, the challenge faced by pet robots focuses on reducing the mechanical sense and setting up appropriate sensors in a limited volume to deal with the required interaction problems, otherwise it may reduce the patient's interaction with the animal-type companion robot [78].

Functional robots can usually tell which functions they have from their appearance. These robots are different from humanoid and animal types.

They usually adopt a mechanical design and focus on interacting with users on tasks with limited applications. Examples of this type are food delivery robots [90], or high-load robots developed by Boston Dynamics [91], which are used to move objects on complex terrain. In this case, emotional interaction is not so important, but focuses on how to effectively complete the task.

In this study, we proposed companion robot BOBO, its design has a cartoon-like appearance and an animal-like tail.

Regarding the tail mechanism design, we review works pertaining to mechanism tails that operate in linkage mechanisms and the research has explored the use of articulated spatial tails that closely resemble biological tails. These tails demonstrate an improved workspace and loading ability around their attachment point to a mobile robot, as well as additional functionalities.

The last part discusses the continuum structure. A recent hot topic in soft robotics has the ability to form continuous curvatures without the limitation of degrees of freedom, has been inspired by the perceived limitations and performance of traditional rigid linkage-based or articulated robotics.

# Chapter 3

## Methodology

The methodology chapter introduces the overall research methods for this dissertation. It is the section explains how this research outline the questions and techniques used to collect, analyze, and interpret data. The goal of this chapter is to provide a brief description of the research process, so that other researchers can understand the study, evaluate its validity, and build on its findings rapidly according to our NHED model and methods. Overall, this chapter provides an overview of the research process and the techniques used to answer the research question.

### 3.1 Research Design

This research design first explain the research methods through "Why do", "What is", "For who", and "How to" in a particular field of study. The study aims to create a comprehensive methodology that will enable the expansion and deepening of the research conclusions using an application system. The technical process is depicted in Figure 3.1. The methodology developed through this research study provide a systematic approach to address the research question and help in advancing the knowledge in the field.

#### Why do?

People feel that they are in a virtual space, besides seeing the virtual world. VR also needs to construct an interactive experience in the VW. The sense of touch is used in the input device to detect gestures to move in the space, and the interactive device is to bring more immersive virtual experiences. In addition, the increasing use of VR devices has brought up various challenges in terms of providing intuitive input devices, incorporating real-life actions into VEs, enhancing interaction and immersion, and integrating physical and virtual models. This dissertation presents one main research question and three specific sub-questions for addressing these challenges.

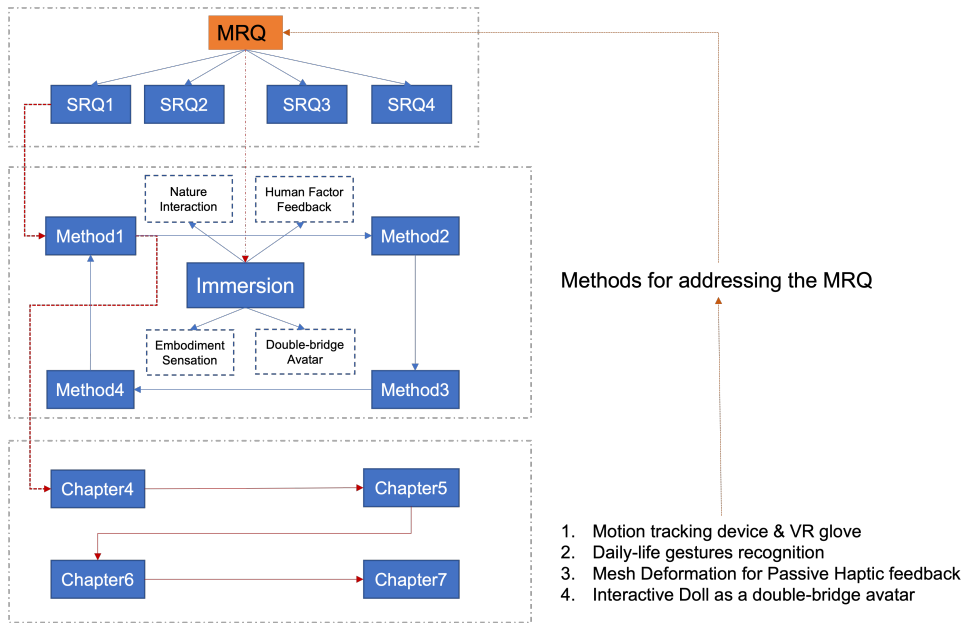

Figure 3.1: Research Technical Process

## What is?

For the definition of intuitive interaction, it is mentioned in the first chapter that intuitive operation allows users to navigate in the VE and interact with virtual objects without much thinking. As for immersion, it creates a sense of presence, so that users have an immersive feeling, making the experience more attractive and memorable. But the definition of this dissertation, what is needed for the intuitive sense of operation is the change of the current VR input device, and how to bring the changes and behaviors observed in daily behavior into the VE, while for the immersive experience, how to provide corresponding feedback to connect the interaction between virtual and reality after the input device is perfected.

## For whom?

The main target audience of this dissertation include three different group of people. First of all, the main target of this work is the developers who develop VR applications. It is hoped that the content of VR research on intuitive interaction and immersion can provide a feasible and evaluable application to help more developers understand and learn. Secondly, the secondary group of this study is players, and it is hoped that the proposed research method can effectively improve the current VR content. Third, I

hope to provide a reference method through the experiment of hardware, software and evaluation methods in this dissertation. The improvement of input devices and the synchronization of virtual and real model feedback are particularly important for the immersive experience at this stage.

## **How to attain the final aim?**

The research design is conducted using a robust and rigorous experimental methodology. The study involves designing and implementing a VR system with the proposed techniques, conducting user experiments, and analyzing the data collected from the experiments. The research design follows a logical and systematic approach to investigating the research question, with a comprehensive literature review providing a foundation for the experimental design. The research design can also to provide a clear and replicable methodology for investigating the effectiveness of the proposed techniques in improving intuitive and immersive interaction in VR.

## **3.2 Methods**

Since the research on the intuitive operation and immersion of VR is complicated, the factors involved are interlocking. Therefore, it is very difficult to obtain a credible result by only conducting research on a single field. Based on the above content and work, this dissertation believes that the evaluation and improvement of existing input devices are needed for intuitive operation and immersion, providing user-accustomed interaction methods and real tactile feedback, and adopting interdisciplinary methods. More importantly, interactions and feedback are agreed upon and reinforced to expand research content and work. Providing intuitive operation and immersion is a difficult problem for VR applications. Interacting with digital content through body movements is an intuitive interaction that allows users to feel the same sense of interaction in the virtual world as in the real world. The tactile and visual stimuli that are directly fed back to the user after the operation can directly increase the user's sense of immersion. Therefore, the main research problem to be solved by the hardware and software proposed in this dissertation is to provide an intuitive and immersive interactive program to increase the immersive experience in VR, that can be divided into three aspects, as follows:

### 3.2.1 Gestures for VR with gloves and motion tracking device

Commercial VR/AR technology has made significant progress, resulting in the release of VR headsets like Oculus Quest, Magic Leap, and HTC VIVE, They have a wide range of applications in areas such as gaming, job training, and virtual socialization. As a new interaction platform, VR is still trying various type of input devices, including mouse and keyboard, buttons and joystick controllers, inertial motion unit (IMU) based motion controllers and wearable devices. Compared with these external devices, hand tracking based on camera [92] or sensor [93] may provide a more convenient and intuitive operation mode. When user is trying to grab a virtual object, the system does not need to give a hint reminding user to operate by pressing a button. However, to become a truly intuitive operation method, hand tracking must provide corresponding responses and feedback between gestures and objects [94]. The technical approach proposed in this dissertation, includes motion tracking device and VR glove as shown in figure 3.2.

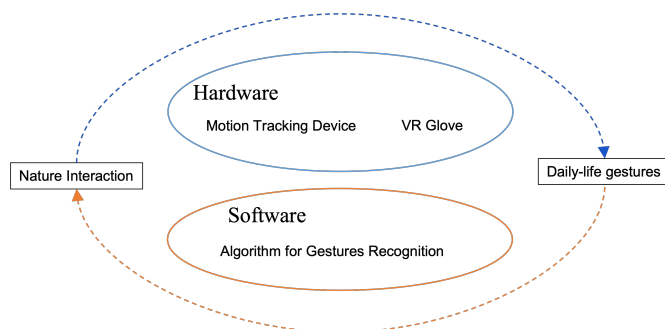

Figure 3.2: Process of achieving Natural Interaction

#### Motion Tracking Device

The motion tracking device consists of a custom fabricated PCB soldered with an IMU sensor (BNO055), a small form MCU (Wemos D1 mini), and a Lipo battery to recognize the user's arm movement by collecting the pitch, roll, and yaw data wirelessly.

#### VR Glove

The VR glove mainly consists of flex sensors that are sewn onto the glove and securely attached to the top of the fingers to read the angle of bend of

each finger and a Wemos D1 mini, that is equipped with a WiFi module to wirelessly sends the angle data.

### **Gestures recognition algorithm for VR Glove**

Gesture interaction is an intuitive operation in VR that can bring people's accustomed operation methods in the real environment into the virtual scene, allowing people to communicate their purpose or intention through different gesture interactions in the 3D virtual scene, and then establish the corresponding Interactive information [95]. In general, gestures can be divided into two categories, static gestures, and dynamic gestures. Static gestures are those gestures that only need to process a single input image programmatically, while dynamic gestures need to process image sequences over a series of time [96]. Currently, most research focuses on the recognition of static gestures [97, 98]. However, in the real world, interactive gestures between users and animals or friends are usually continuous gestures, such as waving, clapping, and touching. Therefore, we generalized 15 static gestures (basic hand shapes) and 3 continuous gestures and conducted a repeat test in Chapter 4. Developed grab, scale, and rotate gestures in Chapter 5. Furthermore, we conduct the evaluation with the questionnaire and EEG that explain in more detail in the following chapters.

### **3.2.2 Passive haptic feedback for VR**

In HCI, haptic devices provide a way of interacting from physical to virtual for the information flow between users and computers, that enhances the interactive experience with the physical feedback brings to users [99–101]. In general, haptic devices can be divided into two types or modes: active and passive feedback. Active feedback is to provide tactile feedback through a device developed based on a power actuator [102]. Passive feedback relies on physical objects to provide tactile feedback for virtual objects [103]. However, regardless of active feedback or passive feedback, physical props are needed to realize virtual simulation. However, according the existing research results, physical devices cannot fully realize composite simulation from physical deformation to virtual simulation. Therefore, this dissertation proposes a composite simulation tactile feedback method, that can realize the bending, twisting, and pressing of physical props through active feedback, as shown in figure 3.3. In addition, to present a passive simulation state in a virtual environment, this dissertation proposes an algorithm. The corresponding grid deformation in VR can be simulated as the passive feedback of the user, and then the composite simulation of the physical device can be realized to



enhance the interactivity and immersive interactive experience.

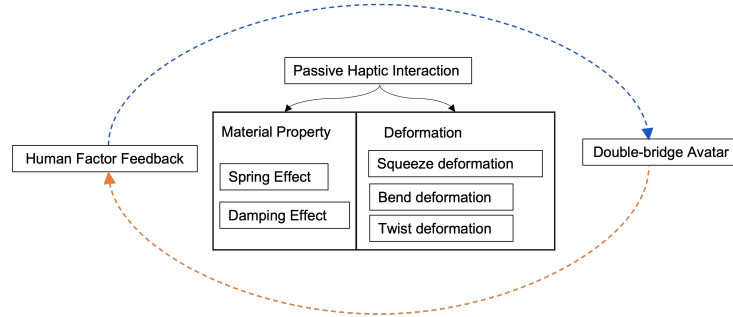

Figure 3.3: Process of achieving Passive haptic feedback

### 3.2.3 Double-bridge avatar in VW and PW

With the further combination of robots and VR technology, it has been derived many novel human-machine interaction methods. Among them, according to the survey results of Anas and Wang [77], it is proven that companion robots in the field of social interaction and human activity recognition can provide an effective way of emotional interaction between man and machine. To further bring this emotional human-machine interaction in VR, we create a new avatar called "Double-bridge Avatar". A double-bridge avatar in VR refers to a representation of the object's body that includes both the object's real-world body movements as well as a virtual representation of the object's body. This type of avatar is sometimes referred to as a "mirrored avatar" or a "full-body avatar." Without a double-bridge avatar, VR experiences may feel less intuitive and immersive for several reasons, such as lack of body awareness, Limited interaction possibilities, Reduced immersion, and lack of feedback.

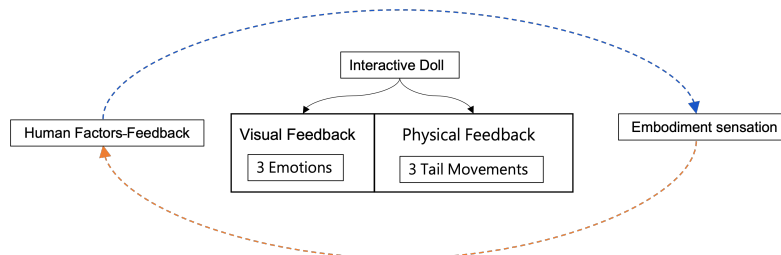

Figure 3.4: Double-bridge Avatar

Therefore, this dissertation has developed an interactive doll, as shown in figure 3.4 that provides physical-tactile feedback, and visual effects. The

visual effects under different emotions in the VE provide the user with a sense of communication, and the tail movement driven by gestures allows people to interact with companion dolls. It supplements an effective way of fostering emotional interaction between VW and PW. Furthermore, we conduct the evaluation with the questionnaire and EEG explain in more detail in Chapter 7.

# Chapter 4

## Motion Tracking And Hand Manipulation

While today's controllers allow users to interact with virtual content through buttons, the use of such controllers can detract from the immersive experience in a 360° VE. This is because button-based controllers cannot simulate the natural movements of human gestures, which can easily break immersion. To address this issue, we developed a wearable motion tracking device to acquire forearm motion data and a virtual reality (VR) glove to simulate the user's finger movements in real-time.

In addition, we propose a continuous gesture recognition algorithm to recognize the gestures used in daily life, thus improving the techniques for intuitive interaction in VR applications. We conducted repeated experiments to verify the accuracy of our developed device and proposed algorithm for recognizing both static and continuous gestures. The experimental results demonstrate that our proposed motion tracking device and VR glove, when integrated with our gesture recognition algorithm, achieve high accuracy rates for recognizing gestures.

In summary, our proposed approach provides a solution for natural and intuitive interaction in VR applications. Our motion tracking device and VR glove enable the simulation of human gestures in real-time, while our continuous gesture recognition algorithm accurately recognizes daily life gestures. By integrating these technologies, we can enhance the immersive experience in VR and facilitate the development of techniques for intuitive interaction.

### 4.1 Introduction

In recent years, the integration of VR with somatosensory operations has become increasingly popular in public life. Users can interact with games using their limbs and gestures through commercial VR equipment and somatosensory equipment [104].

As VR technology continues to mature, the application of somatosensory and VR devices has expanded beyond entertainment to various cross-domain human-computer interaction applications, such as medical care and education.

With the popularity of VR devices, commercial VR equipment like HTC Vive, Oculus, and PS-VR have found more multifaceted applications in human-computer interaction.

For users new to VR, the most familiar aspect of an input device is its shape and size, which influences their initial impression when holding it [105]. A typical commercial handheld device has its own buttons, which users can convert into any indirect trigger and are also the most efficient and time-saving method of operation.

On the other hand, developers of devices like Microsoft Kinect [31], LeapMotion, and VR gloves believe that too many buttons can hinder learning and may cause errors, particularly when controls are not functionally designed. This has led to debates among developers regarding the use of bare-handed, hand-worn, and handheld devices.

However, most current somatosensory operations based on image recognition are limited by distance and equipment [106]. Users must maintain a certain distance from the device to operate it without interference, and the image of the user's upper body must be fully captured for proper positioning. This limitation restricts the user's ability to move freely in space and reduces the overall gaming experience. To this end, this chapter will explain what this research has developed:

- Low-cost motion tracking device
- Gloves for simulating hand movements

Intuitive and immersive VR interactions are designed to simulate a continuous range of motions that closely mimic reality [107]. The goal of the application depends on its target, and interactions serve as the bridge that enables users to achieve that goal. The fidelity of interactions is measured by how closely the physical actions used in virtual tasks match the physical actions used for similar tasks in the real world [108].

To address the gaps mentioned above, we propose a motion tracking device and VR glove that aim to integrate daily gestures into VR to simulate realistic interactions as in the real world. Realistic interactions, such as placing a hand on a dog's head and petting them, have high interaction fidelity and can be crucial for social interactions. Immersive and intuitive experiences can be compromised if interactions are not realistic, leading to negative impressions for real-world tasks.

The benefit of using realistic interactions is that users can perform actions with less learning time [109]. Therefore, we define a series of static and

continuous gestures that mimic realistic interactions and use our proposed devices to recognize them through a series of experiments that validate their effectiveness. This further helps us investigate the proposed device, and the proposed continuous gesture recognition algorithm can provide intuitive and immersive interactions for users in VR applications.

## 4.2 System Overview

The method of implementing the recognition of continuous gestures with the proposed devices is illustrated in Figure 4.1. First, the most critical step is to develop intuitive input devices (VR glove & motion tracking device) that can achieve somatosensory operation in VE. VR glove is adopted to recognize static gestures by detecting the combination of the stretch status of the fingers. Motion tracking devices are adapted to detect the swinging pattern of the forearm using the Example-based Sensor Prediction (ESP) system. We developed the VR application with the Unity game engine, due to this engine supporting the C# language, which allows us to create our customized features and algorithms. So, we implemented static gesture recognition, created the dynamic update list, and set a UDP protocol to receive data from the ESP system and VR glove.

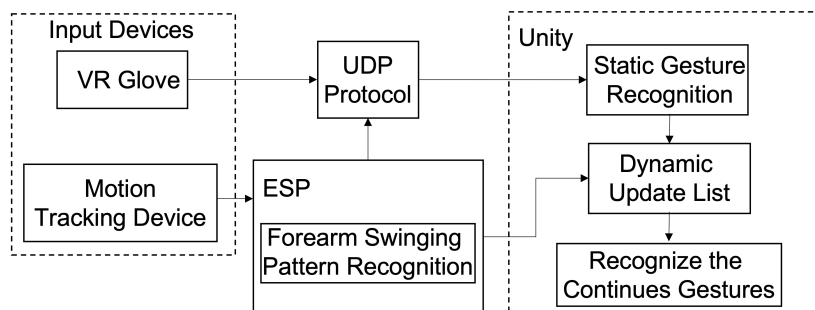

Figure 4.1: Overview the process of implementing the recognition continuous gesture with the proposed input devices.

## 4.3 Design of the wearable IMU motion tracking device

In the past, most of the research methods for integrating somatosensory operations in VR applications were limited to positioning using peripheral

devices such as cameras, which limited the user's movement in space. We developed this device to capture the motion data of the human arm through the inertial sensor, calculate the actual movement angle by integrating the acceleration and gyroscope data, and use the UDP protocol to wirelessly transmit the sensor data to the computer.

### **4.3.1 Device Implementation**

Today's requirements for wearable devices refer to mobile smart devices that can be worn directly on the human body or that can be integrated into clothing, accessories, and record human data [110]. Familiar examples of such devices include Google Glass, Bluetooth headsets, and smartwatches. The small size, easy-to-wear, and wireless function can better meet user expectations. Therefore, this paper selects electronic components according to the above conditions and describes them below.

Since the Internet of Things (IoT) is one of the key research projects in recent years, there are many development boards equipped with WiFi modules on the market, such as Intel Edison [111], NodeMCU [112], etc. Among them, the Wemos D1 mini is the open-source development board with the lowest cost and the most information. To meet the low cost of this research and have a wide range of applications, this development board is selected. With the mature development of inertial measurement unit (IMU) technology based on microelectromechanical systems (MEMS), we used Adafruit's BNO055 [113] nine-axis inertial sensor, which itself includes a geomagnetic meter, a gyroscope, and an accelerometer for output quaternions, Euler angles, rotation vectors, linear acceleration, gravity, orientation, etc., allowing developers to obtain physical data from sensors to develop their related applications. With the electronic components introduced above and testing with a breadboard, to reduce and simplify the overall device for a more comfortable and better experience for users, this research designs and manufactures a small circuit board to save the space of the entire outer box, and uses Fritzing software to design a miniaturized circuit board as shown in the figure 4.2.

### **4.3.2 Software Architecture**

The flow chart of the program of the main control board of the motion tracking device is shown in figure 4.3. The first thing we need to do is import the ESP8266WiFi library and define the SSID and password, for the WiFi credentials. Then we can add the command to begin the WiFi by using the values for SSID and password declared earlier, so make sure you set them

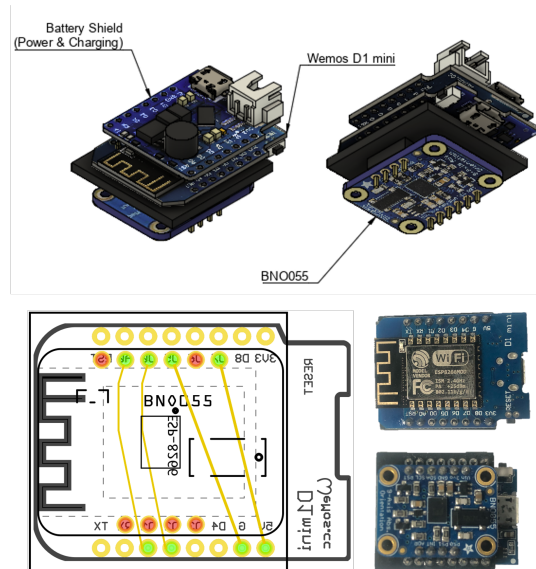

Figure 4.2: The PCB layout and CAD of the motion tracking device.

correctly for your network. If the connection was not made, the program will display information about your WiFi to let users check if it is correct or not. If the WiFi connection is successful, the program will start the I2C channel and check the wired sensor, if the I2C connection is successful, then the program will calibrate the sensor data, and the acquired acceleration data will be converted and sent to the ESP system to recognize the forearm swing pattern.

## 4.4 Design of the VR Glove

Anyone who has ever experienced a VR environment dreams of being able to touch and manipulate virtual objects with their bare hands [114]. For multi-finger interaction, this requires some kind of wearable device, a so-called "VR glove". Recent growth in the VR market has led to increased development of technology. Today, many teams and startups around the world are announcing the imminent release of commercial VR gloves. In fact, a new product was released almost every month last year. In this paper, our VR glove acquires user finger data through a bending sensor set on the glove and simulates the common operation of input devices such as buttons, touch pads, keyboards, and mice provided by most commercial VR controllers.

VR hand input devices can be divided into two categories according to technology: image-based recognition is called bare-hand input devices, and

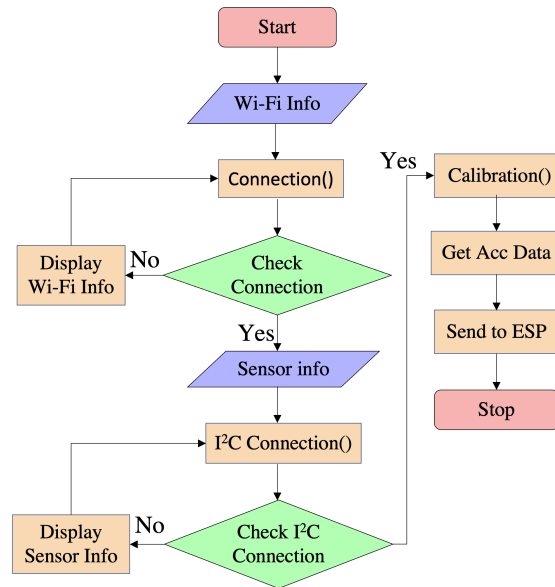

Figure 4.3: Motion Tracking Device Program Flowchart

glove-based recognition is called hand-worn input devices. The image-based recognition uses a camera to capture the hand image, and the gesture features are extracted from the image for recognition; while glove-based recognition uses the data glove to obtain the finger curvature information, and then uses the curvature information for identification.

The bare-hand input device has the advantage that the user does not need to wear an additional device on the body, so the user's acceptance is high. However, the amount of computation required to recognize gestures based on images is relatively large, and the recognition steps are cumbersome because image pre-processing must be performed to obtain hand features. Additionally, when using a single camera to shoot hands, there may be blind spots in the image, and complete hand information cannot be obtained because the hands must be placed in front of the camera at all times, it is easy to cause fatigue. If the number of cameras is added, more complete information can be obtained, but the relative calculation amount will increase, which is a heavy burden for the general system. Although there are difficulties in performing freehand work in VR, the ability to see a person's entire hand in 3D is highly immersive and gives a strong feeling of presence, especially when tracking extended periods of work. However, it is still unclear whether these challenges can be overcome or if users will accept them on a larger scale.

Using data gloves as an input device requires the user to wear additional



gloves, which is inconvenient for the user. However, the information that can be obtained by the data glove is relatively complete, and the computing load is also low, which is suitable for real-time recognition systems and can also handle more kinds of gesture [115]. Therefore, this paper uses VR gloves as the input device. The comparison of the two input devices is shown in the table 4.1.



Table 4.1: Comparison of Bare-Hand and Hand-Worn Device

Input Device	Bare-Hand Device	Hand-Worn Device
Recognition Method	Camera	Sensor
Data Completeness	Lower	Higher
Computation	Higher	Lower
Pre-processing	Demand	No need
User accessibility	Higher	Lower
Cost	Higher	Lower
Gesture Amounts	Few	More

The first step in implementing a gesture recognition system is to obtain information from the hand. We chose VR gloves as the input device to capture the angle of the finger joints and use this information to recognize gestures. Currently, the principles and production methods of VR gloves are mainly divided into three types, as shown in table 4.2: optical fiber [93], resistive [116], and mechanical [117]. The optical fiber glove is used to put the optical fiber in the glove, a group for each finger, sewn around the finger, from the bottom of the finger to the tip of the finger and then back to the bottom, and set the infrared emission and the receiving LED at the head and tail of the optical fiber to receive the light flux change, and then convert it into a digital signal and send it back to the computer. When the fiber finger is bent, the luminous flux also changes with the degree of bending. Using this principle, the bending degree information of the finger is obtained to recognize the gesture. This type of glove is small in size and easy to carry, but the components required are expensive and the sensitivity is not high, and it can only sense whether the fiber is bent, but not the bending direction, so it is impossible to judge the difference between the forceful opening of the finger and the slight bending. Resistive gloves [116] and mechanical [117] gloves use variable resistors or mechanism principles to set variable resistors on the fingers, and with the bending of the fingers, the resistance value changes. This principle is used to capture the bending of the fingers to recognize gestures. The advantages of this type of gloves are that resistance parts are cheap and easy to obtain, and sensitivity is also high, but the loss

rate of resistance parts is high, and most mechanical gloves are complicated in structure or bulky, which is difficult to wear and less comfortable. We organize the characteristics of the above three types of gloves as follows:

Table 4.2: Description of Hand-worn types of Glove

Sensor Type	Fiber-optic	Resistance	Mechanism
Sensing method	fiber optic loop	Variable resistor	Voltmeters and Optical Decoders
How it works	Using the difference of luminous flux to judge the bending degree of fingers	User the difference of resistance value to judge the bending degree of fingers	Use the changed voltage to judge the bending degree of fingers
Advantages	Small size, light weight, comfortable to wear	Inexpensive, high sensitivity	Very high sensitivity
Disadvantages	Expensive, low sensitivity, unable to judge the difference between a finger's hard opening and a slight bend	Large volume, components are easily broken	Bulky, heavy, expensive, difficult to wear, less comfortable
Products Image			

#### 4.4.1 Hardware Architecture

According to the description of the Introduction 4.1, we can understand the advantages and disadvantages of various types of VR gloves. Although mechanical gloves are highly sensitive, they are complicated in mechanism and bulky, and are quite inconvenient for users to wear, so they are not considered. Fiber-optic gloves are comfortable to wear but have low sensitivity and are expensive to manufacture. We want to design VR gloves that are comfortable to wear, highly sensitive, and cost-effective. In the past, gloves used in the field of human-machine interface or VR were mainly imported

from abroad, which were expensive and difficult to maintain. Many research institutions have tried to develop hand-worn devices on their own, which is of great help in reducing costs. However, looking at the gloves that have been developed so far, several major problems can be found:

1. Expensive (fiber type)
2. Not easy or comfortable to wear (mechanical)
3. Parts are easily damaged or difficult to replace (resistive, mechanical)

In view of the above reasons, we need to develop VR gloves ourselves and have completed follow-up research. The key points of glove design are as follows:

1. Under the cost constraints, design measurement to obtain information on the curvature of each finger.
2. Increase wearing comfort and durability.
3. Select the components that are easy to obtain to facilitate the follow-up maintenance.

The VR glove can be divided into two parts: the glove and the data frame. Bend sensors are sewn onto the glove and securely attached to the top of the fingers to read the angle of bend of each finger, as shown in figure 4.4.

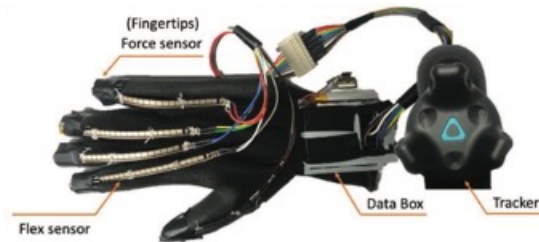

Figure 4.4: VR Glove

The data box consists of a Wemos D1 mini, which is equipped with a WiFi module that allows us to perform wireless data transmission [118], and an ads1015 that can expand the analog pins to five pins, including the A0 pin on the microcontroller unit (MCU) pins, and a custom printed circuit board (PCB) with five 10k Ohms SMD resistors to minimize the box size, as shown in the figure 4.5. Finally, we obtained hand spatial position data through the HTC Vive tracker (HTC Corporation, Taiwan).

A clear circuit layout is shown in figure 4.6. customized PCB part, the schematic shows an analog-to-digital signal converter connected to the Wemos D1 mini and five analog sensors. To minimize the circuit size, we

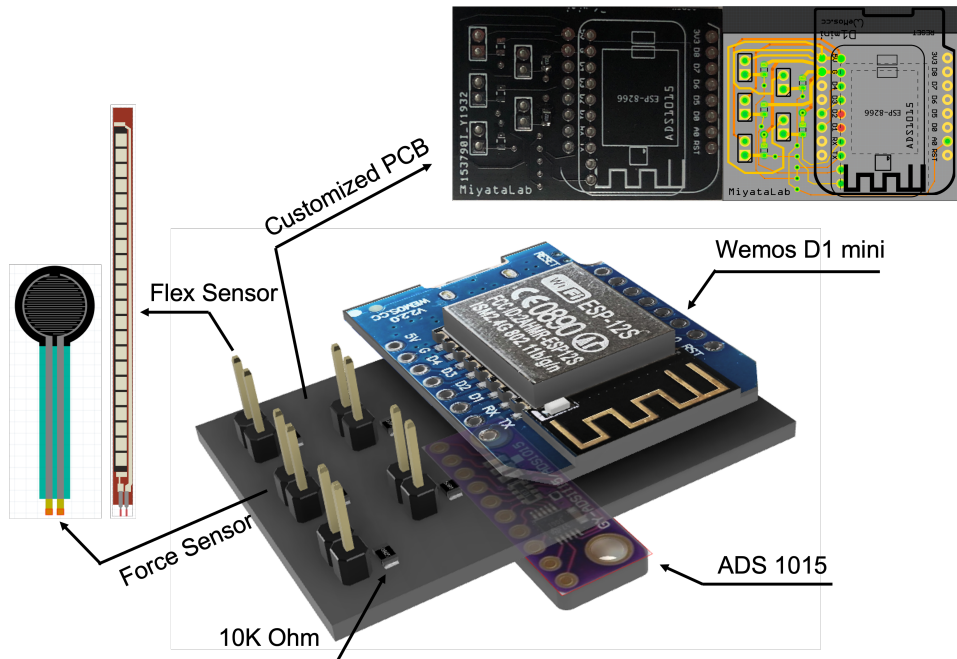

Figure 4.5: PCB Layout and Sensors on Glove

used 0805 SMD resistors to connect the sensor signal pins and the Wemos D1 mini digital pins.

#### 4.4.2 Software Architecture

The flow chart of the VR glove program is shown in Figure 4.7. In the beginning, the WiFi connection process is the same as the process shown in figure 4.3. Once the WiFi connection is successful, then do the calibration to get the finger curl angle (map the sensor value in the range of  $0^\circ$  to  $180^\circ$ ) and the pressure value of the tips. In the end, send the value through the UDP protocol to the VR application made by the Unity Engine (see figure 4.1).

### 4.5 Wireless Data Transmission

Wireless communication is crucial for wireless controllers because being tethered to a computer can create a physical and psychological barrier that separates the user from the device [119]. The need to keep track of the cable when using a wired solution can distract the user by requiring them to be aware of the position of the cable to avoid tangling or pulling it out [120].

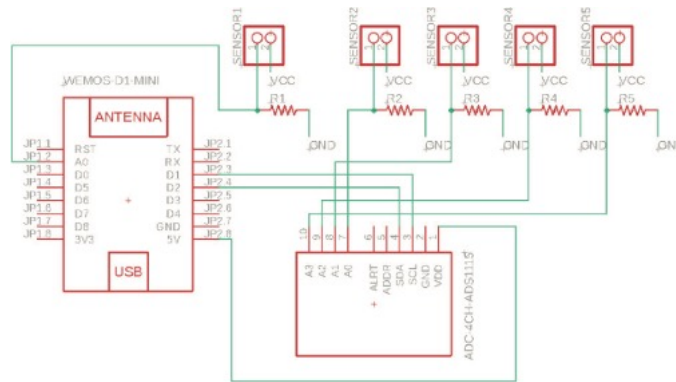

Figure 4.6: The PCB schematic of VR Glove

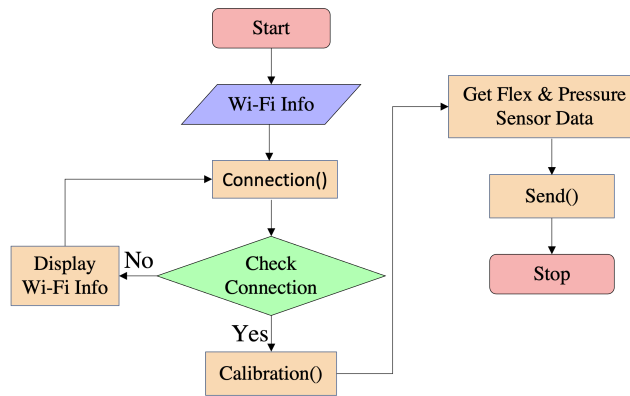

Figure 4.7: VR Glove Program flow chart

Wireless transmission of sensor data is also an emerging area that enables the development of real-time monitoring systems [121].

In this research, we used the Server/Client method to carry out the wireless function. We compare the TCP/IP and UDP protocols. We found that because the TCP/IP needs to confirm the data correctness if the client's end had received the data incorrectly, the TCP/IP will ask the Server's end to resend it again. This property makes the angle data transmission delayed, this will make the user's experience feel not smooth. UDP protocol does not need to confirm the data correctness, and due to our send speed of around 100 ms, if there are some data that are wrong, this will be covered from the next data, so that the user will feel more intuitive. In addition, we also performed a test of the transmission speed under the UDP and TCP protocols, as shown in figure 4.8. In this experiment, a timer was established in the data-receiving function to time the total data received from the server under the two different protocols. The time unit displayed through the Unity

window is milliseconds, as shown in figure 4.8 (a), when the server receives ten pieces of data through the UDP protocol, the total time spent is 1.05 seconds, the transmission interval is approximately 0.1 seconds and the delay time is approximately 0.05 seconds.

As shown in Figure 4.8 (b), when the server receives ten pieces of data via the TCP protocol, it actually takes 1.5 seconds, and the delay time is about 0.5 seconds. The data transmission speed of the TCP protocol itself is not slow, but because the reliability of this paper is relatively low to achieve more real-time sensor data transmission, the TCP protocol itself will pause slightly to wait for the correct data transmission. When the data are sent, the hand model in the game will be temporarily stagnant when waving, and the UDP protocol itself only performs data receiving and data transmission between the client and the server and does not confirm the correctness of the data. Due to the fast transmission speed, lost data will be immediately replaced by the next sent data, so even if part of the data is lost, the system will directly use the data the next time. The lost sense of pause is greatly reduced, making the user experience more intuitive.

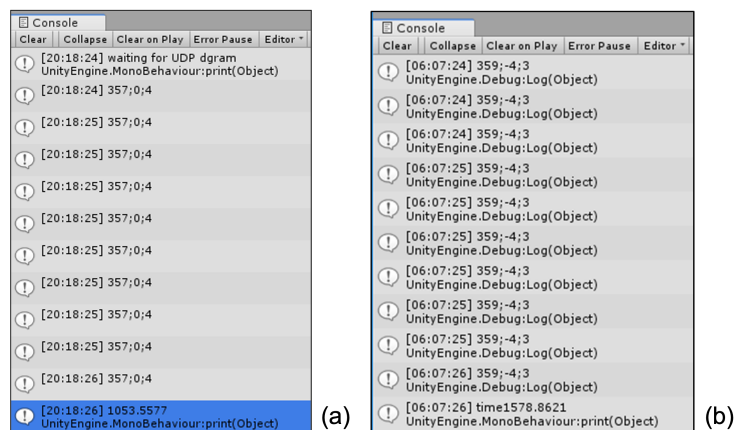

Figure 4.8: Comparison of UDP and TCP protocol.

Due to the experimental results, we chose the UDP protocol to receive the data from our proposed device and the results from the ESP system. In the beginning, to ensure that the receiving process does not interrupt the recognition procedure, we create a new thread for the UDP receiving protocol. Once the connection has been connected, the thread starts to receive data and split to get the glove data and the result of the swinging pattern of the forearm, as shown in figure 4.9.

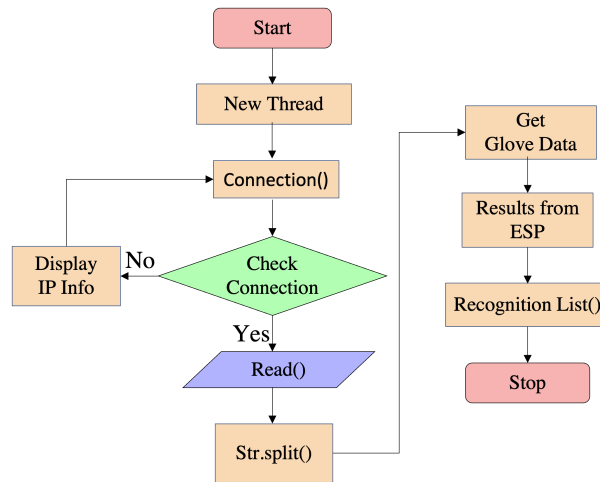

Figure 4.9: Unity UDP program flow chart

## 4.6 Persistent Gesture Recognition

Gestures are movements of the body or body parts, whereas gestures are a single static configuration. Whether intentional or not, each conveys some meaning. Dynamic gestures consist of a static gesture plus acceleration (i.e. gestures within a short period of time or gestures with imperceptible motion). Gestures can convey four types of information.

Gestures can refer to spatial information, such as the spatial relationship of objects. These gestures can be used for various purposes, such as manipulating objects (e.g., pushing or pulling), giving instructions (e.g., pointing or drawing a path), describing form (e.g., indicating size), describing function (e.g., twisting motion to convey screwing), or using objects. Such direct interaction can be a very effective form of communication in VR, as it allows for direct manipulation of virtual objects. This direct interaction refer to physical movements that directly interact with virtual objects in a VR environment. This type of interaction is highly effective because it provides a structured communication that directly affects the objects in the virtual environment [122].

Symbolic information [123] refers to the symbol conveyed by a gesture, which can represent concepts such as greeting with a wave or indicating rudeness with a finger gesture. Such this structural communication involves the formation of gestures, while indirect communication involves their interpretation. Symbolic information conveyed by gestures can be used in human-computer interaction and human-robot interaction [124].

Perceptual information refers to the use of gestures in a process that

involves thinking, such as speaking with one’s hands subconsciously [125]. Perceptual information is the most common form of instinctual communication. It is not only useful for indirect communication but also for human-to-human interactions.

Emotional information [126] refers to the emotional state conveyed by a gesture, such as pain, relaxation, or enthusiasm. These types of gestures are typically a visceral communication and are used to express emotions, and can be useful in various human-to-human interactions.

In the PW, gestures enhance communication with signs such as OK, Stop, Mute, Goodbye, Point, etc. Gloves and gestures were common input methods for early VR systems as well [122, 127]. Gestures offer several benefits such as flexibility, the ability to utilize the degrees of freedom of the human hand, and the fact that they do not require holding a device. Additionally, gestures can be executed when the hand is not visible, or at least not in a direct line of sight. Learning and recognizing gestures in VE can be challenging, similar to learning a language as it requires the memorization of gestures. However, most current systems struggle with recognizing multiple gestures, leading to low recognition rates [128]. The use of gloves as input in VR systems is preferred over camera-based systems due to their consistency, even though they may not be as comfortable. Gloves can reduce false positives and eliminate line-of-sight issues. This is especially true when users communicate with other people, not just the system itself.

#### **4.6.1 Implementing method**

In this research, we define continuous gestures as composed of static gestures plus the direction of hand waving for a period of time. First, we use the stretch sensor on the VR glove to obtain the bending data of each finger to recognize static gestures. The direction of the hand swipe was performed by machine learning using an accelerometer and dynamic time warping (DTW) to identify the direction of the swipe. The machine learning tool we use is the Example-based Sensor Prediction (ESP) system developed by Mellis et al [129]. ESP is a platform that enables developers to implement pipelines for their own projects by continuously changing training data and adjusting pipeline parameters. At the same time, ESP offers a set of visualizations and operations that are not tied to a specific pipeline, and these are based on prior research. This provides a unified interface for beginners to handle training data, customize pipeline behavior, and visualize their results. It offers various features such as visual representations for different stages of the pipeline, starting from the sensor input to the final output features. It also provides numerical metrics for identifying confusion between different classes



of training data, along with real-time graphs that display the distribution and confidence of pipeline predictions. These features help novices manage the training data, customize the pipeline behavior, and visualize the results easily. After getting the result of the static gesture and swipe direction, we input the two results into the continuously updated list for time-continuous identification.

Our method is different from traditional machine learning identification methods. Most of them use a hidden Markov model or decision tree algorithm for identification. All of the above methods must obtain a large number of samples and establish a regular grammar of state transitions, record the sequence of state transitions, and follow the time points to make a judgment. In contrast, we use the stretch sensor to obtain absolute finger bending information to obtain static gesture recognition results and add the corresponding acceleration data to further identify continuous gestures. Therefore, this method is more suitable for simple interactive gestures.

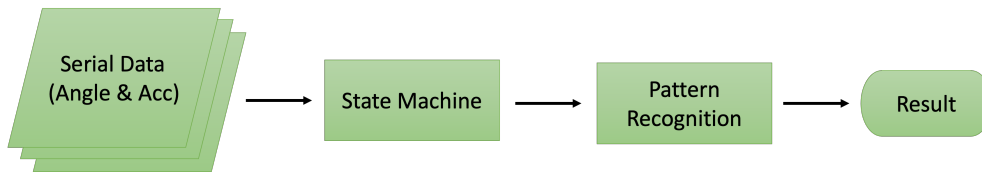

Figure 4.10: Persistent Gesture Recognition Working Flow

### Static Gesture Recognition

In the static gesture recognition part, this paper uses a self-developed VR glove and uses the stretch sensor installed on it to classify the basic hand type, as shown in 4.11.



Figure 4.11: Static Gesture performed by VR Glove

We generalized 15 static gestures (basic hand shapes) as shown in figure 4.12.

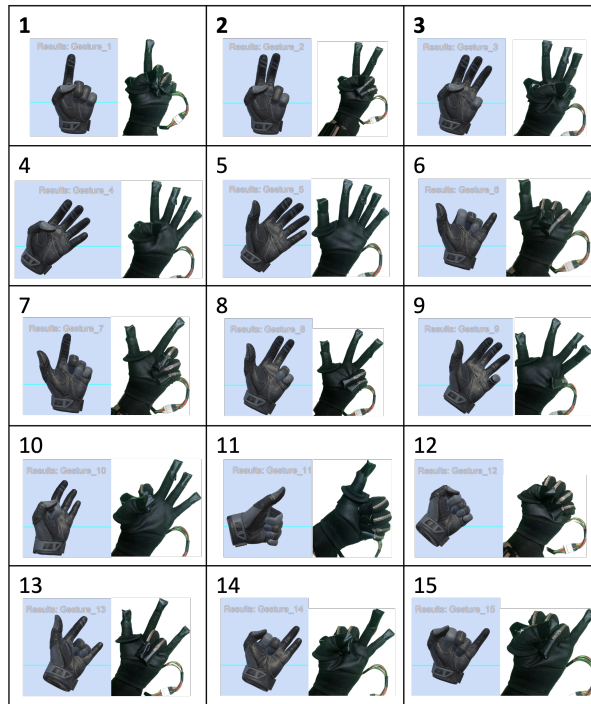

Figure 4.12: Static Gestures List

### Acceleration Recognition for Hand Waving Direction

In the part of hand wave direction recognition, ESP is to instantiate the machine learning pipeline using the DTW classifier provided by GRT [130]. The input stream of the ESP pipeline receives accelerometer data from a Wemos D1 mini board that is connected via USB serial. We have implemented a calibrator in the code, enabling the use of accelerometers with varying ranges. In the beginning, we record three forearm movement's acceleration waveform characteristics (SwipeUp, SwipeDown, and Poke) as shown in figure 4.13.

Once we have recorded some examples of forearm movements, we can train the ESP system to recognize those movements from the recorded data. Now, when we make a forearm movement similar to one of our recorded examples, we could see its name appear on the plot of live sensor data as shown in figure 4.14. Through this example, we can also find that other sensing data can be added to identify customized applications.

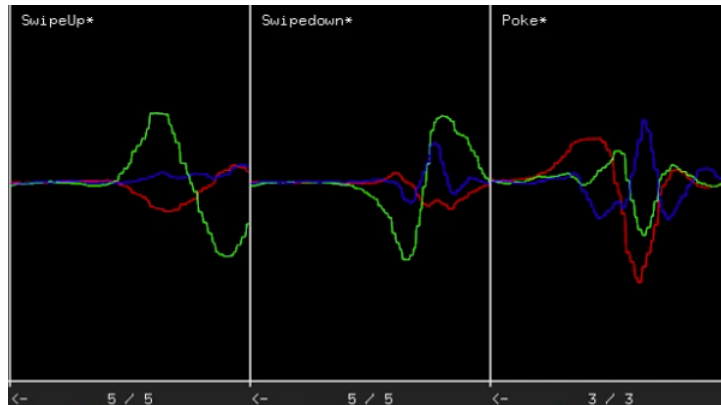

Figure 4.13: Three types of forearm movements acceleration waveform characteristics

### Continuous Gesture Recognition

Input the static gesture and hand waving direction at each time point into the list updated in real-time, and judge that the continuous gesture recognition method can be realized when a certain number of recognition results are obtained in this interval. First, Unity will receive the recognition results returned by the gloves and ESP, so we build a list with a size of 20. In the absence of any data changes, the list will always be stuffed with a false value. When there is a time point if the recognition result conforms to a certain static gesture and the corresponding direction, the value at this time point will be corrected to true. When it is judged that the number of true values in the list meets a certain number, it is judged to be the corresponding continuous gesture as shown in the figure 4.15.

The 3 continuous gestures as shown in 4.16

## 4.7 Experiment and Results

The subjector wears an HTC Vive Pro helmet, our VR gloves, a motion tracking device, and a Vive Tracker as shown in 4.17 to see the hand inside the VE. Before starting, we asked the subjector to wave their arms up and down and forward. The purpose is to obtain the acceleration characteristic data that match their own and import them into the ESP system. After that, the subjector is asked to repeat the gesture 30 times as the test data.

We conducted a repeat test, the recognition rate can reach 89%, and the average recognition rate is 9%. List the average recognition rate of each gesture in figure 4.18.

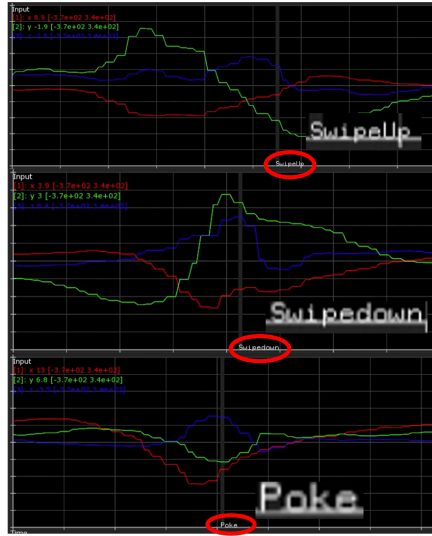

Figure 4.14: The prediction results overlaid on the plot of live sensor data.

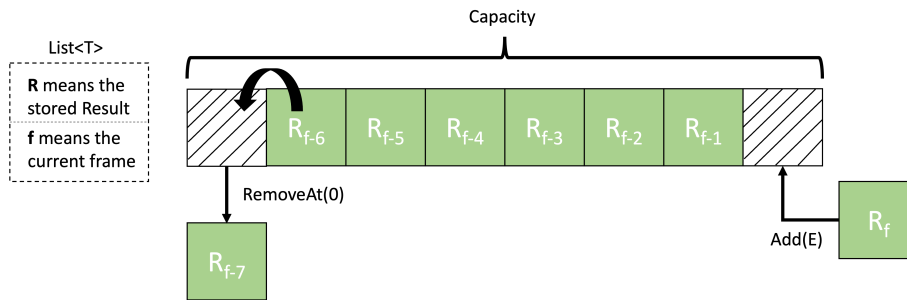

Figure 4.15: Adding and Removing result for updating the List

## 4.8 Conclusion and Discussion

To provide the intuitive and immersive interaction for VR application, we first use the BNO055 and the Wemos D1 mini, a small development board with a WiFi module, to build a motion tracking device that can acquire the acceleration data of the forearm swing, and the motion result of the user's forearm swing is predicted through the built-in DTW classifier of the ESP system. We then developed a VR glove by sewing flex sensors onto the fabric glove to read the angle at which the user's finger was bent. For the choice of data transmission, after comparing the transmission speed of the UDP and TCP protocols, we found that the UDP protocol has a faster transmission speed, so we choose to use the UDP protocol to transmit the obtained forearm swing prediction results and the angle of finger bending to



Figure 4.16: Continuous Gestures List



Figure 4.17: Continuous Gesture Device

a VE built using the Unity engine. Finally, we define 15 static gestures and 3 continuous gestures and conduct repeated tests to evaluate the success rate of each gesture to recognition. By using our proposed device and the continuous gesture recognition method, it can allow us to successfully implement common gestures in our lives in a VE to enhance the immersive experience.



















		1	2	3	4	5
Static Gestures						
		90%	93.3%	80%	86.6%	100%
		6	7	8	9	10
						
		100%	93.3%	100%	93.3%	56.6%
Continuous Gestures		11	12	13	14	15
						
		100%	100%	80%	40%	83.3%
		16	17	18		
						
	86.6%	36.6%	100%			

Figure 4.18: Gestures Average Percentage

## Chapter 5

# Comparison of the Intuitive and Immersive Feeling with Existed VR Input Devices

People in VR applications are not limited to interactive experiences in the form of screens but are surrounded by artificial virtual panoramas. Typical interactions are gestures, which can be further converted by different input devices through different interaction methods. Currently, conventional VR input devices can be tracked in space, but different hardware designs are available for gesture interaction. Different types of input devices have their own advantages and disadvantages for user interaction in VR applications. Therefore, to verify the effectiveness and immersiveness of gloves and other input devices, we designed different virtual scenarios and performed a series of user experiments. The results of the experiments can reveal the learnability, effectiveness, and degree of intuitive interaction provided by each input device.

### 5.1 Introduction

Since the invention of the typewriter, human beings have long been accustomed to button-type interaction [131]. However, in the application of VR, people are not limited to the interactive experience in the form of a screen but are immersed in an artificial virtual panorama [3]. At this time, if the button is used, the user's immersive experience will drop sharply. Gesture interaction can be further transformed by a variety of input devices through different interaction methods, but the operating characteristics that different forms of input devices can provide to users are slightly different. Controllers, such as keyboards, mice, and other grounded devices, can trigger virtual hands to grasp objects through key combinations. This process of pressing the button into a natural gesture interaction will not make the user feel immersed in the 2D interaction [17]. At present, common VR input devices

can be tracked in space, but the hardware design of gesture interaction is different. The first type is HTC's Vive Wands and Quest's Touch, which are based on buttons and joysticks, and the second type is the Knuckles Controller proposed by Valve. Actions are simulated on virtual hands, and the third type is pure hand interaction, such as LeapMotion tracking the user's gestures in real-time through image tracking, and the other is our proposed VR glove [132]. However, these three types of devices have their own advantages and disadvantages for the user interaction process in VR applications. Therefore, in this chapter, in order to verify the effectiveness and immersion of gloves and other input devices, we designed different virtual scenarios and performed a series of user experiments. For the first virtual scene, we choose the cup stacking competition as the experimental task, because in the cup stacking competition, the operation of the user's hands and the speed of time can well reflect the differences between various devices. The second virtual scene is modified according to the experimental scene proposed by Sachse et al. [52]. We design two different shapes of objects that can be changed by user gestures and rotated to the correct angle. put in the correct position.

To more fully understand the user's feedback on the operation experience of different types of input devices in VR applications, the experiments proposed in this chapter can be divided into two types, subjective experiments, and objective experiments. First, in the subjective experiment, we take the interaction of grasping gestures as the main form, because grasping gestures are the most common gesture interaction methods in daily life. There is a positive response to degree and effectiveness. In order to integrate the two forms, we choose the cup stacking competition as the experimental task. In addition, we design a Likert scale questionnaire to investigate the user's perception of each type of input device after completing the interactive task. Finally, we used multivariate analysis to analyze the time results corresponding to each device and sorted out the user-supplied values in the questionnaire to evaluate the technical achievement and intuition provided by the different devices. Second, in the objective experiment, we chose to design the zoom gesture in addition to the grasping gesture, because since the touch screen technology became popular in portable smart mobile devices, zoom gestures are the most common to browse flat content.

To make VR applications popular in daily life, the most acceptable way for users is to simulate some daily interaction gestures in the VE and be acceptable to users, so we additionally designed zoom gestures. On the other hand, the brain wave measurement device is used to obtain the brain wave data corresponding to the user performing different gestures to analyze the user's immersion level to different types of devices. Therefore, the results



of the two experiments allow us to understand the learnability, effectiveness, and degree of intuitive interaction provided by each input device.

## 5.2 Research Method

To evaluate the performance of VR input devices implemented to provide immersive and interactive gesture manipulation, a user-based evaluation was conducted. Since there are no standardized measurements available for VR applications, this chapter first reviews the literature on current VR evaluation methods. To organize the problems addressed by previous literature, a framework and heuristics for VR evaluation were developed. Based on heuristics, questionnaires, and EEG were also developed and used to investigate participants' perceptions of system usage. Both qualitative and quantitative data come from user-based tests. Through the statistical analysis, the technical achievement and degree of intuition provided by the different devices were evaluated.

And after the device is developed, we explore how the VR input devices of each device type feel differently to users. We compared gesture manipulation in three devices; using:

1. A handheld device (Vive Wands, ValveIndex).
2. A bare-hand device (LeapMotion).
3. A VR glove and motion capture device developed in this study.

We classified the following properties and analyzed the effect of each property on different devices utilizing questionnaires, which will be explained in the fourth section of this chapter.

**Ease of learning:** We aim to evaluate the learning cost of each VR input device, can users become familiar with pure hand interaction in a short period of time?

**Effectiveness:** The goal of VR input devices is to provide users with a more intuitive and immersive experience, and this is the criterion for evaluating the effectiveness of each device.

**Scalability:** Which device has more potential and can be extended to other applications?

However, while the questionnaire has many positive elements, dishonesty can be a problem. Participants' answers may not be 100% true. This can happen for various reasons, such as trying to protect social preferences and privacy. Such miscommunication can lead to biased results.

Therefore, the integration of biofeedback from the user state with VR

and augmented reality (AR) systems is critical to provide a more immersive and functional VR experience in various applications.

The immersive nature of VR leads to intense sensory stimulation that can elicit strong emotional and cognitive reactions in the brain. To study the neural mechanisms underlying these immersive experiences, EEG can be utilized to measure changes in brain activity in response to VR stimuli.

Studies have demonstrated the feasibility of utilizing EEG to monitor changes in brain activity in response to VR experiences [133]. For example, studies have found that exposure to immersive VR environments can elicit changes in brain activity in regions associated with attention, emotion, and memory [134]. EEG can also be used to measure changes in brain activity during different phases of immersive experiences, such as anticipation, engagement, and disengagement.

Advances in current EEG devices with dry and non-invasive EEG electrodes and motion artifact suppression provide a logical, practical, and easy-to-setup framework for mounting EEG devices in VR headsets. Passive or implicit EEG analysis [135] refers to the monitoring of a user’s cognitive or emotional state without requiring them to perform any explicit tasks. This type of analysis can be used to influence other aspects of the VR interaction, and is more practical for integration into VR systems. This EEG analysis can be designed to be less sensitive to subjective bias and may be less obvious and distracting to the user than a questionnaire. Therefore, this passive monitoring signal is expected to increase VR engagement and immersion as well as obtain objective data. This study aims to build on previous work to evaluate the intuitive user experience provided by VR input devices through passive EEG feedback. To ensure reliable EEG measurements of cognitive workloads using an interactive VR environment, in Section V of this chapter, we employ LooxidLink [64] to modulate cognitive workloads into an immersive VE using the HTC Vive Pro headset. The details of the VE are intentionally designed as a geometric three-dimensional puzzle game. Cognitive workloads help us evaluate differential feedback for each device.

## 5.3 Scenarios Design

### 5.3.1 VR cup stacking game design for Subjective Experiment

Hand-eye coordination refers to the ability of the eyes and hands to work together in a coordinated way. In VR, this is essential for tasks such as grabbing objects, manipulating them, and navigating through the environment. If a

user has good hand-eye coordination, they will be able to move through the VE with ease and perform tasks with greater accuracy and efficiency. [136]

Reaction time refers to the duration between a stimulus and the user's response to it. In VR, this can be important for tasks such as dodging obstacles, reacting to enemy attacks, or catching a falling object. A user with fast reaction times will be able to respond quickly to changes in the VE, which can help them avoid obstacles and stay safe [137]. Hand-eye coordination and reaction time can be related to intuitive experience in VR, as they are important factors in how well a user can interact with a VE.

Both hand-eye coordination and reaction time can be improved with practice, and this can lead to a more intuitive experience in VR. As a user becomes more familiar with the VE and the tasks they need to perform, they will develop a better sense of how to interact with the environment and how to respond to different stimuli. This can lead to a more natural and intuitive experience in VR, where the user feels like they are really part of VW.

Therefore, we design a VR cup stacking game by integrating the grab gesture and using time results to evaluate the device's preference and the intuitiveness and immersiveness experience. This task requires the players to stack the cups regularly and restore them in the fastest time. For the scene part as shown in figure 5.2 and 5.3, we used Blender to design a table that complies with the Sport Stacking competition rule book, a table width: 72.5-77.5 cm (29-31 inches), length: 180-187.5 cm (72-75 inches), height: 72.5- 77.5 cm (29-31 inches) to ensure that participants see the real size in the VW. We have changed some of the competition rules in VR. The original 3-3-3 project required 9 cups, each in a group of 3. Players must first stack each group of cups into a pyramid, and then reassemble them to return to their original shape. Because it is quite difficult to simulate the cup stack together in Unity, we let the user does not need to do the original final step. In place of that, there are three tasks, as shown in figure 5.1, and one of them will be randomly assigned when participants press the start button. To complete the cup stacking task, they need to follow the order specified in the task image. To simulate a real case of intuitive manipulation, we set up two interactive modes: the 180° front test and the 360° surrounding test, which will be explained in this subsection.

### **State of Presence Experiment Design**

In VR, the terms 180° and 360° refer to the scenarios that present to users can experience within a VE.

A 180° VR experience means that all the main interactable digital objects are placed in front of the user. This type of VR experience is typically used

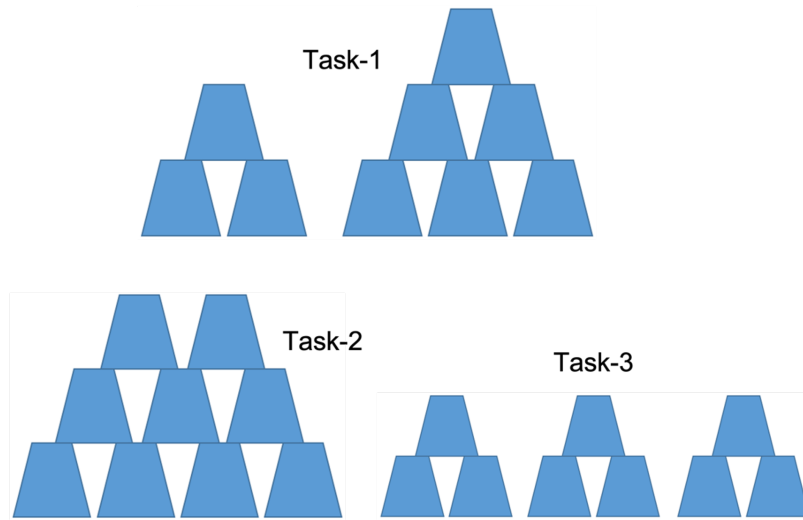

Figure 5.1: Cup stacking tasks

for more focused and directed experiences, such as training simulations or educational experiences, where the user's attention is meant to be focused on a specific area or task.

A 360° VR experience means that the user can see and interact with everything around them. This type of VR experience is typically used for more immersive and exploratory experiences, such as games, entertainment, and tourism.

Both 180° and 360° VR experiences have their advantages and disadvantages. 180° VR experiences can be easier to design and develop, as they require less visual content and can be more focused on specific tasks or learning objectives. 360° VR experiences, on the other hand, can be more immersive and engaging and can offer a more natural and intuitive way to explore a VE.

In summary, the choice between a 180° and 360° VR experience depends on the goals and objectives of the experience, as well as the user's needs and preferences. While both types of VR experiences have their unique benefits, they can both offer exciting and engaging ways to experience VEs. Therefore, We set up two states of spatial presence scenarios to investigate the difference between the types of VR input devices.

#### **First state of spatial presence scenario (FSP)(180°)**

In the 180° scenario, participants were placed in the center of a room simulating a cup stacking competition. The cups were already placed on the table and the participant's view was restricted to 180° of the room. The scene behind the participant was all black, as shown in figure 5.2.

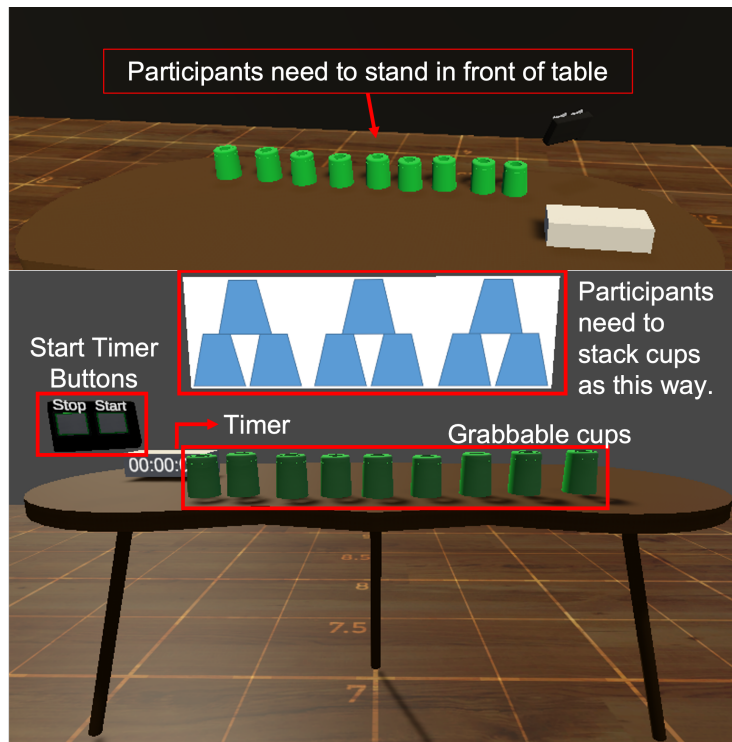

Figure 5.2: The backside of the scene was black, to let the user focus on the cup-stacking task.

### Second state of spatial presence scenario (SSP) (360°)

Unlike the first state of spatial presence scenario, the cups will appear randomly and surround the participant, forcing the user to look around and pick up the cups, as shown in figure 5.3.

### 5.3.2 Scenario of EEG Experiment

This experiment scenario came from a jigsaw puzzle. We designed a scene through the Unity engine, which included star-shaped and triangle-shaped objects as shown in figure 5.4. Participants needed to use gestures to adjust the angle, scale, and position of the objects to match the corresponding hollow.

## 5.4 Device Setup

The user is immersed in the VR application by wearing a HMD (HTC Vive Pro) with position tracking and can be based on a gesture tracking device

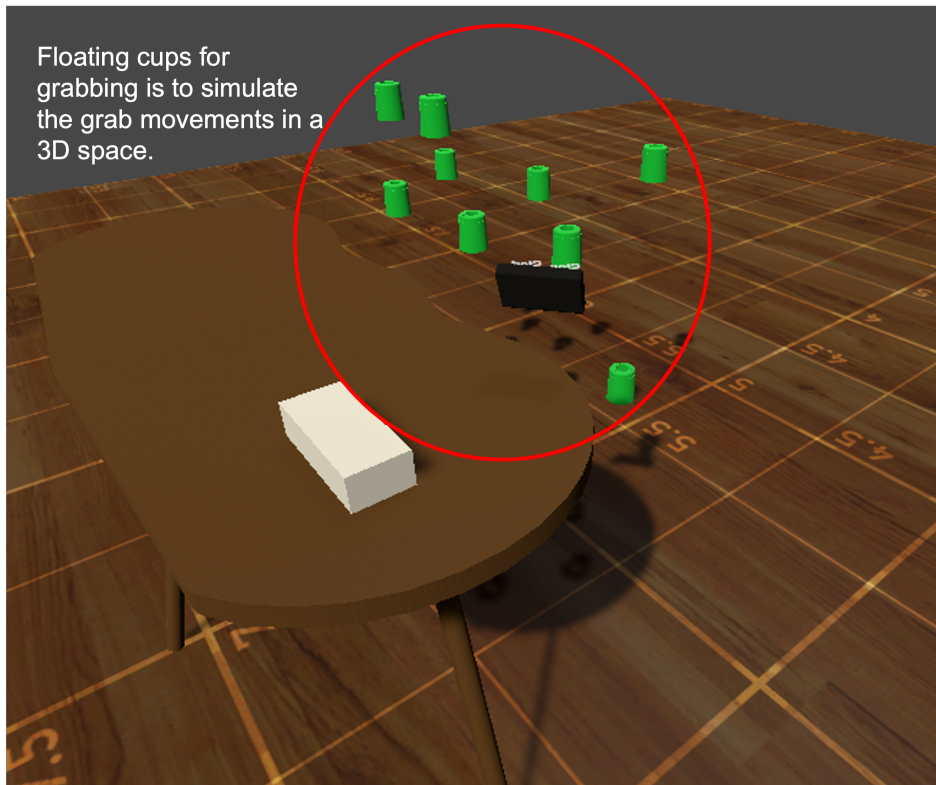

Figure 5.3: There are no black screens to restrict the user's eyesight.

(Leap Motion) mounted on the HMD, or a handheld device (Valve Index & Vive wand) interact with the VR glove, as shown in figure 5.5.

VR setup: To create a VR environment, the user experience the VR application by wearing a HMD (HTC Vive Pro). In the PC hardware configuration, the processor is an Intel(R) Core i7-i7-8750H CPU, the highest is 4.10GHz, and the memory is 32GB. To provide a better visual experience and interactive effects for the experiments, we used an NVIDIA GeForce GTX 1070 8GB as a graphics card.

Hand Tracking: We use three different types of devices for hand tracking. Hand-held device (Valve Index & Vive wand): Vive wands have 24 sensors that can track movement in space through a lighthouse (a kind of IR stream emitter) and a set of triggers to interact with virtual objects. The Valve Index controller features a joystick, a touchpad, two face buttons, a menu button, a trigger, and a set of 87 sensors that are capable of tracking the position of the controller in space, finger bending, movement, and pressure to simulate the finger movement of the user in VR as shown in figure 5.5 (c & d).

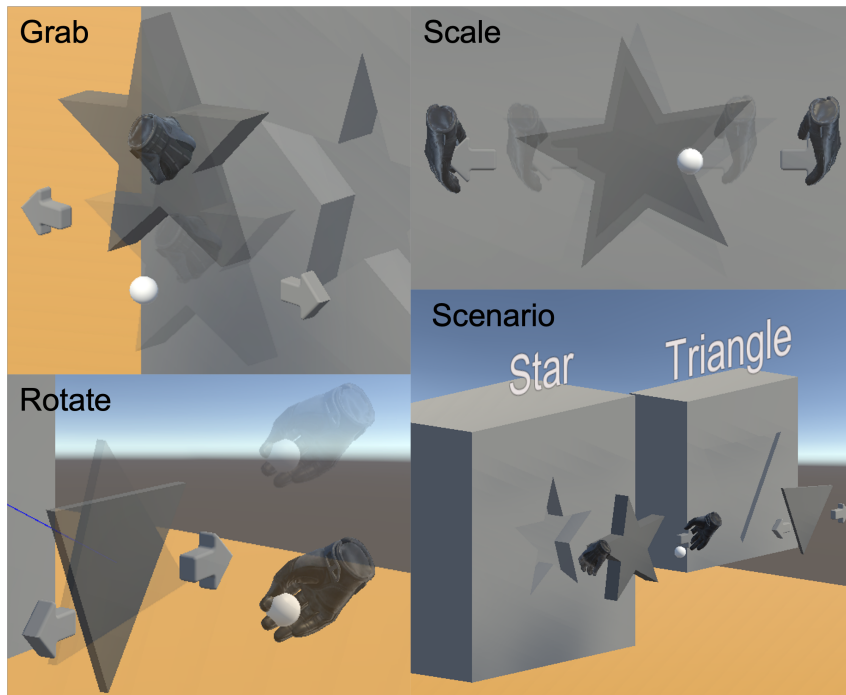

Figure 5.4: The scenario for EEG experiment

Bare-hand device: LeapMotion uses infrared scanners and monochromatic IR cameras to map and track the human hand. This information is used to create digital versions of indicators that can manipulate digital objects in real-time. Therefore, we mounted LeapMotion in front of the headset so that the virtual hand of the user is always present in the scene, letting the user know that their hands are well tracked, as shown in figure 5.5 (a).

hand-worn device: Here we used the VR glove proposed in section 3.4, which can be divided into two parts, the glove, and the data box; The glove part has five flex sensors sewed to read the angle of the finger joint of five fingers. The data box includes a Wemos D1 mini, which is equipped with a WiFi module that allows us to implement wireless data transmission, an analog-to-digital Converter (ADC) expansion circuit board, ads1115 [138] was adopted to extend the analog pins to five pins, including the A0 pin on the MCU, and a custom PCB SMD resistor with five 10k Ohms to minimize box size; a Vive tracker was used to track the user's hand position in space; the setup is shown in figure 5.5 (e).

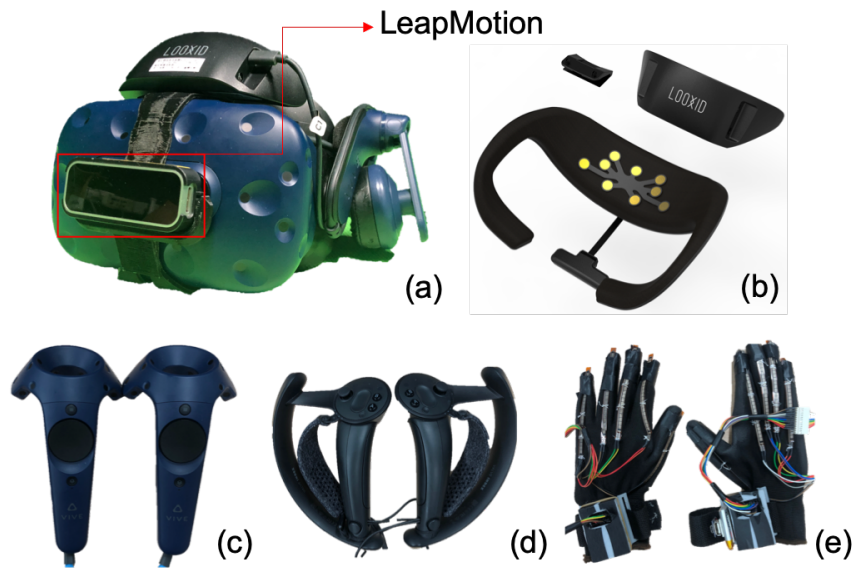

Figure 5.5: Types of VR Input Devices.

## 5.5 Intuition Experiment Design

The purpose of this user-based test is to evaluate VR systems developed for gesture manipulation of different devices by utilizing questionnaires and analysis of users' EEG brainwaves. The detailed process is as follows.

### 5.5.1 Participants

We recruited 20 participants (8 males and 12 females) on campus through advertising to participate in our experimental study. The age of the participants ranged from 23 to 27 years ( $M = 24.5$ ,  $SD = 1.51$ ). We divided 20 people into two groups, each group consisting of 4 men and 6 women, to experience the first and second scenes, respectively. The participants were allowed to explore the application we developed before solving the task. For this group, it can be assumed that they have little experience with Hand-Worn devices and Bare-Hand devices (only two said that they had ever used LeapMotion to develop VR applications).

### 5.5.2 Procedure

Testing with participants who have not used VR controllers requires some special considerations. First, they do not know exactly how to use controllers,



especially handheld controllers, so they need verbal instruction. Instructions must be presented in a standardized manner, as small changes in wording can significantly impact interactions. A male instructor read out the task to all subjects and first invited them to move their fingers or press the corresponding button to activate the grab gesture in a VE.

The first group of participants experienced the first state of spatial presence (FSP) scenario. Before starting the operation, the participant must press the start button to start counting time, and the system will randomly assign the stacking task to the participant. When the cup stacking task is complete, press the red button to stop the timer. We let the participant rest for one minute and play the game again to collect the first and second results. The second group of participants experienced the second state of spatial presence (SSP) scenario, and the procedure was the same as in the first scene. Participants who had experienced VR equipment were less attentive. To motivate them to complete the test, we told participants that this task is time-competitive, so do it as quickly as possible.

### **5.5.3 Experiment Design For Questionnaire**

#### **Grab Interaction Design**

Interacting with virtual objects on head-mounted VR devices like Oculus Quest and HTC Vive has typically involved using grab interactions. For the handheld device, the SteamVR plugin in Unity already provides basic interactive development functionality. Therefore, for the grab function of Vive wands and ValveIndex, we use the plugin to implement the grab interaction. For the bare-hand device, UltraLeap provides Unity3D assets for developers who intend to create content using LeapMotion. It contains essential grab interaction functions. For the hand-worn device, make sure that the manipulation will not have too much difference from than above two devices. We refer to their grasping interaction design, which has the following utilities: object proximity detection, grab recognition, and object following. For example, for grasping objects, when the hand is close to the target to be grasped, the target's color will change to bright red, which reminds the user that the hand is close to the effective distance. Then, the position of the target object will move with the palm when the grab gesture is detected.

## Questionnaire Design

The results of our experiment are similar to those reported by Blackler et al (2010) [139], indicating that users can leverage prior experience with similar products to quickly adapt to a new controller with similar functions. We found that appearance and perceptual style were the most significant variables affecting the time spent on the task and users' intuitive use of the device.

However, during the design of our time comparison experiment, we realized that our methods did not fully capture the relevant elements of the user's intuitive interactive experience provided by different devices.

We looked at different sources, such as the VR book [15], showing that questionnaires are commonly employed to assess interfaces that are currently in use or have some operational aspect. Participants can use the Likert scale to indicate their level of agreement with statements about a particular topic, ranging from strongly disagree to strongly agree. The scale is balanced, with an equal number of positive and negative positions. This scale is commonly used to evaluate interfaces that are already in use or have some operational component.

Furthermore, the literature on intuitive decision-making in psychology, the literature on human-computer interaction, and subjective reports of people's use experiences collected in interview studies [140]. Participants reported specific experiences in interacting with products they found intuitive and easy to use. Products cover a wide range (such as software, mobile phones, digital cameras, music players, home appliances, game consoles, answering machines, printers, navigation systems, copiers, etc.). They reflect on how they operate the product and the associated feelings and thoughts. After describing specific interactions, they also expressed a personal view of what a kind of intuitive interaction is and what a typical characteristic is.

In summary, to investigate intuitive and immersive feedback and the potential of each device, we decided to conduct a questionnaire to include various experiential features of intuitive interaction. With the above discussion, our questionnaire is based on the structure recommended in the VR book [15], and uses a 5-point Likert scale, for VR applications and integrated hand motion recognition technology in immersive and intuitive interaction evaluation.

### 5.5.4 EEG-based Evaluation Design

To avoid obtaining subjective data for the intuitiveness and immersiveness feedback from participants, we design an experiment for acquiring and

analyzing EEG signal from participants.

## EEG Sensors

Based on neuroscience research, we have found EEG sensors corresponding to this region on the user’s forehead, which contain information about emotions [141,142] in the prefrontal region of the brain. The selection of specific points (FP1, FP2, AF3, AF4, AF7, and AF8) was based on the International 10-20 system, a standard for electrode placement in EEG recordings [143]. The 1mm thick sensor is coated with gold tin and paste on flexible circuit boards (Figure 5.5 (b)). The benefit of this approach is its flexible circuit board, allowing you to adapt comfortably regardless of the different shapes of the forehead.

## Event Annotation in real-time

In order to analyze biometric data accurately, it is important to have precise timing information about when events occurred and to synchronize this information with corresponding biosignals [144]. Each point contained in the EEG system has different data, and events representing content changes and user-expected reactions always occur arbitrarily. Therefore, in a multi-modal sensing environment, it is important to annotate the collected data based on the events to accurately analyze the data. Our system has effectively implemented the annotation process to ensure that the recorded brainwave data corresponds accurately to the time-stamp of each individual event as shown in figure 5.6.

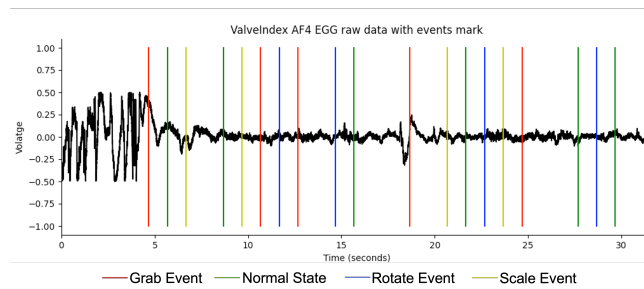

Figure 5.6: EEG raw data with events marked

## Signal Preprocessing

In general, brain wave electrical signals are susceptible to interference from various sources such as visual movements and electrical equipment, which can

introduce noise into the data. Therefore, raw EEG data must be processed in two stages to reduce it and improve signal quality. First, EEG data are digitally filtered by a 0.01-120 Hz band-pass filter and a 60 Hz stop filter to reduce the noise of power lines. Afterward, the artifacts and headset slip artifacts are eliminated by independent component analysis (ICA) and modified brain wavelet methods [145]. In fact, this preprocessing contributes greatly to eliminating EEG noise caused by user movements. We import Looxid Link unity SDK to acquire the raw data. However, to annotate the data under certain events, we modify the acquire method from their sample code.

In their document, they mentioned "Filtered EEG raw signal data in the last 4 seconds. Includes 2,000 double-type data (500 data per second)." [146]. We need the latest raw data inside the package so the acquisition method pseudo code is as follows.

We first simplified some names from their source code:

1. OnReceiveEEGRawSignals => ORES.
2. EEGRawSignal => ERS.
3. rawSignalData => rSD.
4. FilteredRawSignal => FRS.
4. Electrodes => can be one of the AF3, AF4, AF7, AF8, FP1, or FP2.

---

**Algorithm 5.1** Raw data acquisition and annotation algorithm

---

**Output:**  $i = 1500$ ,  $skipCount = 0$   
**function ORES(ERS rSD)**  
1: *double*[] *dataList*  
2: skipCount ++;  
3: **if** skipCount < 8 **then**  
4:     **return**  
5: **end if**  
6: skipCount = 0;  
7: *dataList* = rSD.FRS(Node)  
8: *dLength* = *dataList*.Length  
9: **for**  $i \leq \textit{dataList}$  ,  $i ++$  **do**  
10:     txt.WriteLine(*dataList*[*i*]);  
11: **end forend function**

---

### Feature extraction and selection

EEG signal analysis typically involves extracting five main characteristics, which in turn generate around 300 characteristic dimensions. These

characteristics include time-domain features such as non-stationary index (NSI), fractal dimension (FD), and higher-order crossings (HOCs), as well as frequency-domain features (  $\alpha$  (8-14 Hz),  $\beta$  (14-31 Hz),  $\gamma$  (31-50 Hz),  $\theta$  (4-8 Hz), and  $\delta$  (1-4 Hz)), and time-frequency-domain features (discrete wavelet transform (DWT)) [143]. Furthermore, several studies have suggested that the alpha and theta frequency bands of EEG are related to the level of immersive feeling in VR experiences [134, 147].

The alpha frequency band (8-14 Hz) is associated with relaxed wakefulness and attentional disengagement, while the theta frequency band (4-8 Hz) is associated with memory consolidation and spatial navigation [148].

Research has found that increases in alpha power during VR experiences are associated with a greater sense of presence and immersion in the VE. Specifically, alpha power increases have been observed in brain regions involved in visual processing and attention, suggesting that heightened attentional engagement with the VR environment may be a key factor in generating a sense of immersion [149].

Similarly, increases in theta power during VR experiences have been associated with improved spatial memory and navigation within the VE, which may contribute to a sense of presence and immersion. Our system applies the power spectral density (PSD) feature extraction and classification the density of alpha and the density of theta result for Welch method [150].

## 5.6 Results

### 5.6.1 State of Presence Experiment Results

To examine whether each type of input device is easy to learn, we collect the completion time, which is the time that the participants complete the tasks in the first T1 and the second T2, as shown in table 5.1 & 5.2. It shows us that when the participants use the same device for the second time, the time results are improving. The learning cost is obviously low on the handheld device. For example, users who use a handheld device (Means (M) of Vive wands T1= 35.9, T2= 22.9, ValveIndex T1= 38.1, T2= 28.9 ) are better than bare hands (M T1 = 78.4, T2 = 32.8) and a hand-worn device (M T1 = 41.1, T2 = 23.2).

We conducted a MANOVA test to verify the difference between each device. The results show that statistically significant differences in time performance are observed in four input devices tested in FSP,  $F(6,70) = 3.724$ ,  $p < .003$ ; Wilk's  $\Lambda = 0.575$ , partial  $\eta^2 = 0.242$ . In the SSP,  $F(6,70) = 5.918$ ,  $p < .001$ ; Wilk's  $\Lambda = 0.44$ , partial  $\eta^2 = 0.337$ . Scheffe's post hoc

Table 5.1: Participant’s completion time in FSP

Group	Type of Input Device				Means	
	Vive Wands	Valve Index	LeapMotion	VR Glove		
Participants	T1	32, 61, 27, 90, 15 25, 30, 19, 16, 44	43, 47, 27, 18, 25 18, 60, 22, 63, 58	58, 42, 45, 121, 62 27, 101, 142, 96, 90	55, 51, 55, 23, 12 58, 78, 23, 16, 40	
	T2	22, 55, 14, 16, 12 23, 27, 17, 9, 34	35, 47, 13, 17, 23 12, 52, 13, 51, 26	39, 42, 34, 18, 41 19, 21, 51, 37, 26	30, 34, 40, 20, 8 15, 10, 18, 22, 35	
Means	T1	35.9	38.1	78.4	41.1	48.38
	T2	22.9	28.9	32.8	23.2	26.95

Table 5.2: Data for the complete time in Surroundingness (360°) test

Group	Type of Input Device				Means	
	Vive Wands	Valve Index	LeapMotion	VR Glove		
Participants	T1	34, 24, 29, 24, 18 25, 31, 21, 34, 28	33, 52, 26, 24, 47 60, 24, 28, 52, 37	60, 51, 46, 40, 71 44, 46, 53, 50, 46	32, 40, 22, 57, 33 44, 50, 56, 42, 55	
	T2	19, 16, 19, 21, 26 25, 24, 19, 16, 20	31, 18, 21, 21, 24 28, 21, 31, 20, 25	45, 29, 25, 28, 47 28, 44, 28, 27, 26	29, 30, 20, 62, 25 34, 44, 35, 41, 31	
Means	T1	26.8	38.3	50.7	43.1	39.73
	T2	20.5	24.0	32.7	35.1	28.08

test was conducted for multiple comparisons. The results of the analysis are shown in table 5.3 & 5.4. In the FSP test, LeapMotion took the longest time to complete the task (M T1 = 78.4s, T2 = 32.8s). Furthermore, if we look at LeapMotion in the T1 section, there is a significant difference between the handheld device ( $p_{Wands} = .002$ ,  $p_{ValveIndex} = .005$ ) and the VR glove ( $p = .008$ ). However, in the T2 section, LeapMotion has a similar time (M T2 = 32.8s) with other input devices and does not have a significant difference with Vive wands ( $p = .416$ ), ValveIndex ( $p = .959$ ) and VR Glove ( $p = .444$ ). For the SSP test, LeapMotion still took the longest amount of time to complete the task in the T1 section (M T1 = 50.7s). However, VR Glove took the longest time in the T2 section (M T2 = 35.1s). Vive wands get the fastest time to complete the task (M T1 = 26.8 s, T2 = 22.9 s) and have a significant difference with VR Glove ( $p = 0.010$ ), LeapMotion ( $p < .001$ ) and ValveIndex ( $p = .121$ ). However, in the T2 section, Vive wands and ValveIndex have similar time results (M  $T2_{Wands} = 20.5$  s,  $T2_{ValveIndex} = 24$  s), but faster than LeapMotion and VR Glove (M  $T2_{LeapMotion} = 32.7$ s  $T2_{Glove} = 35.1$ s).

## 5.6.2 Questionnaire Results

Figure 5.7 & 5.8 shows the result of our questionnaire. Figure 5.7 shows the Likert scale scores that the participants rated their experience. The highest intuitiveness mean value (mean = 4.1) locates in the Handheld device, both

Table 5.3: Multiple Comparisons in first scene

DV	Type (I)	Type (J)	MD (I-J)	Std. Error	Sig.
T1	Vive Wands	Glove	-5.2	11.33	0.975
		LeapMotion	-47.3	11.33	0.002
		ValveIndex	-3.1	11.33	0.995
	Glove	Vive Wands	5.2	11.33	0.975
		LeapMotion	-42.1	11.33	0.008
		ValveIndex	2.1	11.33	0.998
	LeapMotion	Vive Wands	47.3	11.33	0.002
		Glove	42.1	11.33	0.008
		ValveIndex	44.2	11.33	0.005
	ValveIndex	Vive Wands	3.1	11.33	0.995
		Glove	-2.1	11.33	0.998
		LeapMotion	-44.2	11.33	0.005
T2	Vive Wands	Glove	-0.3	5.79	1.000
		LeapMotion	-9.9	5.79	0.416
		ValveIndex	-6.7	5.79	0.722
	Glove	Vive Wands	-0.3	5.79	1.000
		LeapMotion	-9.6	5.79	0.444
		ValveIndex	-6.4	5.79	0.749
	LeapMotion	Vive Wands	9.9	5.79	0.416
		Glove	9.6	5.79	0.444
		ValveIndex	3.2	5.79	0.959
	ValveIndex	Vive Wands	6.7	5.79	0.722
		Glove	6.4	5.79	0.749
		LeapMotion	-3.2	5.79	0.959

Table 5.4: Multiple Comparisons in second scene

DV	Type (I)	Type (J)	MD (I-J)	Std. Error	Sig.
T1	Vive Wands	Glove	-16.7	4.61	0.010
		LeapMotion	-23.9	4.61	<0.001
		ValveIndex	-11.5	4.61	0.121
	Glove	Vive Wands	16.7	4.61	0.010
		LeapMotion	-7.2	4.61	0.495
		ValveIndex	5.2	4.61	0.737
	LeapMotion	Vive Wands	23.9	4.61	<0.001
		Glove	7.2	4.61	0.495
		ValveIndex	12.4	4.61	0.083
	ValveIndex	Vive Wands	11.5	4.61	0.121
		Glove	-5.2	4.61	0.737
		LeapMotion	-12.4	4.61	0.083
T2	Vive Wands	Glove	-14.6	3.54	0.003
		LeapMotion	-12.2	3.54	0.015
		ValveIndex	-3.5	3.54	0.806
	Glove	Vive Wands	14.6	3.54	0.003
		LeapMotion	2.4	3.54	0.927
		ValveIndex	11.1	3.54	0.032
	LeapMotion	Vive Wands	12.2	3.54	0.015
		Glove	-2.4	3.54	0.927
		ValveIndex	8.7	3.54	0.129
	ValveIndex	Vive Wands	3.5	3.54	0.806
		Glove	-11.1	3.54	0.032
		LeapMotion	-8.7	3.54	0.129



Barehand and the Hand-worn device have the same intuitiveness mean value (mean = 3.9). Participants feel that their experience is more intuitive on the bare-hand device.

Figure 5.8 shows the scores of immersiveness and the scores of extensibility for each device. The highest immersiveness mean value (mean = 4.12) locates at the LeapMotion device, the second immersiveness mean value (mean = 3.37) locate at VR Glove, the third immersiveness mean value (mean = 2.75) locate at ViveWands, and the lowest immersiveness mean value (mean = 2.5) locate at ValveIndex controller. Participants felt that their experience is more immersive on the bare hand device, no matter on the FSP or SSP. For the extensibility mean value, the highest value (mean = 4.5) locate at the LeapMotion, the second value (mean = 4.37) locates in the VR Glove, the third value (mean = 3.5) locate at the ValveIndex, and the lowest value (mean = 3.12) locate at the LeapMotion. Participants felt that BareHand and HandWorn devices have great potential for applying in other types of VR applications.

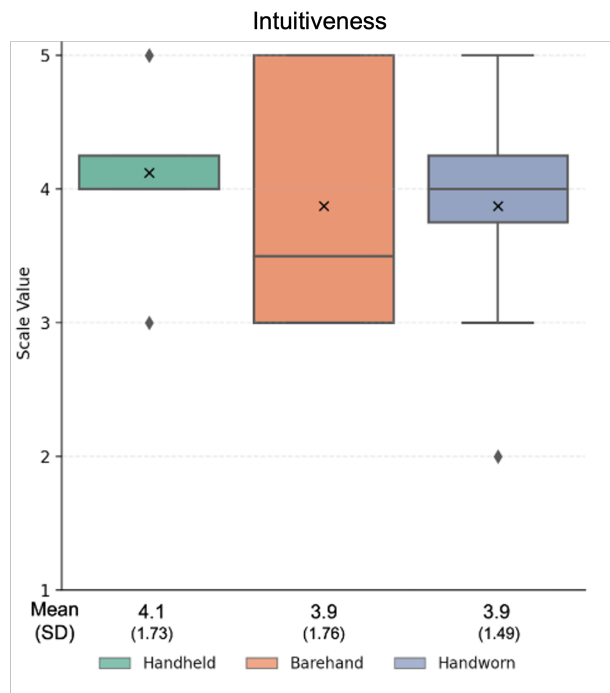

Figure 5.7: Intuitiveness

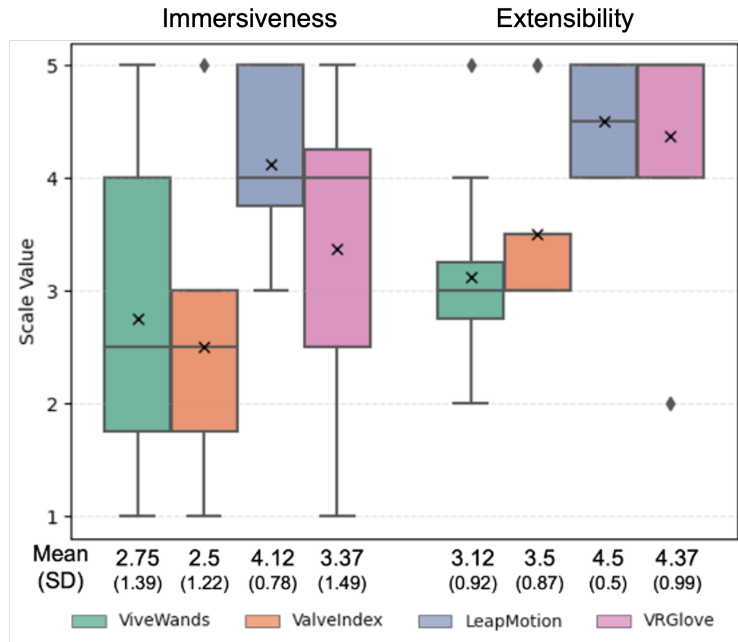

Figure 5.8: Immersiveness and Extensibility

### 5.6.3 Result of Analyzing user EEG signal

We analyzed the significance of each gesture events with different VR input devices. Considering the Normal state, we found significant effects: When participants using ValveIndex controller, their brainwave has high activity in both  $\theta$  band and low  $\alpha$  during normal state, for the electrodes AF4. Considering the Rotate, Grab and Scale gesture events, we found significant effects: When participants using LeapMotion, their brainwave has higher activity in both  $\theta$  band and low  $\alpha$  than the other three devices, for the electrodes FP2. Figure 5.9 shows the PSD examples in the four gesture events (Normal, Grasp, Scaling, Rotation) for the four VR input devices respectively.  $\theta$  waves play a greater role in creativity, intuition, memory recall, and navigation within VE. And the low  $\alpha$  waves are the most extensively studied rhythm of the human brain and can be usually observed while being in a relaxed awake state [68]. During the PSD analysis process, it was found that participants reported feeling more intuition while using LeapMotion in virtual environments, which was considered a significant achievement.

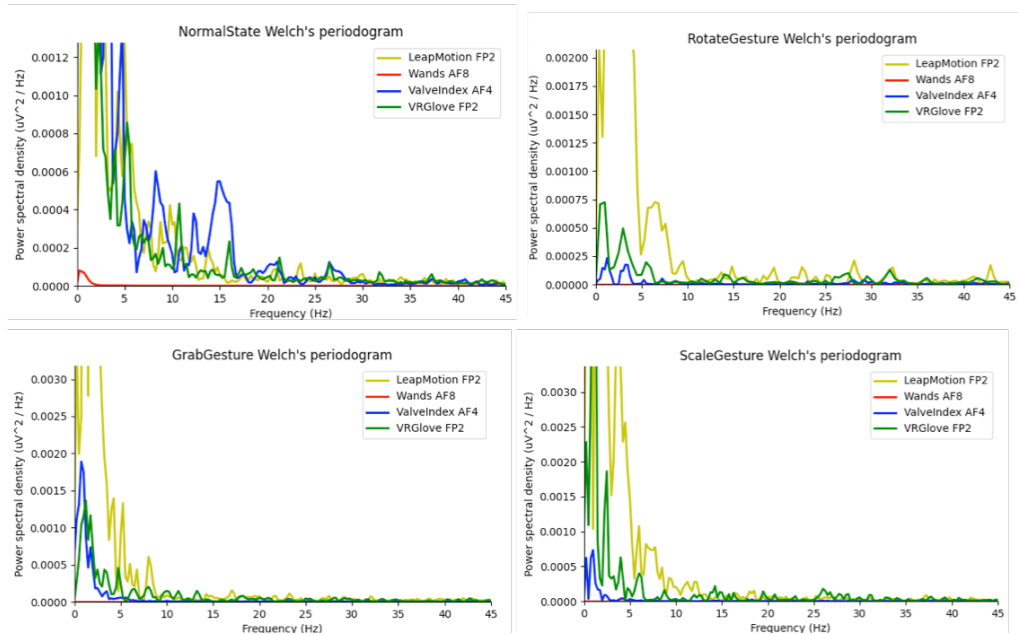

Figure 5.9: PSD of Normal, Rotate, Grab, and Scale (Gesture events) for four devices (mean of all subjects).

## 5.7 Discussion

Currently, input devices used for VR gesture interaction have different types of operations. However, for interactions in VR applications, different types of input devices provide different intuitive operations and immersion. Therefore, this chapter summarizes the following three attributes: Learnability, Effectiveness, and Extensibility are related to the intuitive operation and immersion that the device can provide to the user. In addition, in VR interaction, EEG is used to explore the intuitive operation and immersion of the device. The immersion that can be provided is also relevant, especially the *alpha* and *theta* in the brainwave frequency. Therefore, the following is a summary and discussion of the analysis results of the three major attributes and brainwaves.

### 5.7.1 Device Learnability

In the FSP, the average times of T1 and T2 are quite similar for the handheld and hand-worn device, except the bare hand device, which takes longer than the others, as shown in table 5.1 & 5.2. That is because the participants are familiar with the button-based interaction from their daily experience.

Bare hand and hand-worn device that is quite fresh for them to use physical hand gestures to interact with the digital content in the VW. P8 in group A reported that interaction through bare hand devices has the following problems. "When the cups are too scattered, I accustomed to grasping the target with both hands, but my sight does not follow the hand all the time, which will lead to hand tracking failed. When I stretch my hands, the camera has a limited range and cannot track my both hands well, significantly prolonging the time it takes for me to complete the task." However, when the participants used LeapMotion for the second time, they learned how to avoid these limitations and spent less time than before, and the result is close to the handheld device. For the hand-worn device, P1 in group A said that "When he used it for the first time, the grasping works really smoothly in the VW as in the PW. " We also can see the time result from Table 5.1, which shows that the VR glove time result is close to the handheld device. There are also no statistically significant differences for each device, as shown in Table 5.3 & 5.4. In the SSP, we expect that the time result will be longer than in the FSP. However, the result was not as long as in the FSP. P7 in group B said that " Although the cups are surrounding us, the distance is not too far from us. We still can grab them like what we do in the PW. "In this case, we see that the performances of the bare hand and the hand-worn device are quite close to the ValveIndex. Apparently, the learning cost for the bare hand and hand-worn device is quite low for users who are first-time using it because pure hand interaction is what people do in their daily life.

### 5.7.2 Device Effectiveness

With any one of the VR input devices, the participants give positive value to the intuitive experience. When experiencing our VR cup-stacking game, the participants prefer to use the handheld device, as can be confirmed in figure 5.7. The reason is that this application is a competition, and participants want to finish the task faster than the others.

When we ask the participants, "When I use the following devices, I can ignore the equipment (e.g. headset and gloves) and immerse in the VE." P7 in group A said that "With the finger, movements can be simulated, I will be more immersed and feel more realistic in the VE. " In summary, the intuitive and immersive experience of each device depends on the task-oriented VR application.

### 5.7.3 Device Extensibility

For the extensibility of the device, VR developers often strive to enable users to achieve an intuitive interactive experience with the VW through different input devices. In real life, one of the typical interaction methods, such as moving and clicking with a mouse or moving and pressing with a finger on a touch screen, has always been a traditional interaction method. This mapping method is easier to implement in flat interaction; however, this interaction mechanism is challenging to give users a real interaction experience in a three-dimensional space or without any instructions. In the three-dimensional virtual space, achieving natural interaction in reality is difficult and complex [151]. During our survey, we asked participants to select the device they believed could offer the most intuitive user experience, there was not much difference between the four devices, but the participants said LeapMotion in addition to the recognition of grasping things, the response of finger simulation is excellent. The second-best device is the VR Glove. It can be seen that gestures play a critical role in improving immersion. Although in our experiments, users may not be able to quickly grab and release objects, raising their hands in the air can simulate a more realistic interaction, and most users believe that this type of device can be extended to other VR applications and help users become more engaged in virtual interactions.

### 5.7.4 Discussion of the EEG analyzing result

Avtanas et al. [68] explains that  $\theta$  play a greater role in creativity, intuition, memory recall, mood and feeling. And  $\alpha$  are the most widely studied human brain rhythms and can usually be observed in a relaxed waking state. Considering the grab event is where the participant touches the dummy directly and moves it, this means it's a simple gesture. The wand was the most relaxing device when participants made the grab gesture. But Leapmotion is the most intuitive device for users. The scale and rotate events refer to the tasks that require the user to modify the size and angle of the virtual object. This means they need to be more careful when operating gestures. Leapmotion is the easiest device for the user, but the button-based devices (Wands and ValveIndex controllers) are the most intuitive for the user. One of the biggest accomplishments found during the analysis was that the overall event results showed us that participants felt more intuitive and relaxed when using the wand in the VE. In the current situation, button-type devices are still suitable for users, but from user feedback indicate that Leapmotion has great potential to provide an immersive experience.

## 5.8 Conclusion

The wireless wearable device developed by this research can be used with commercially available VR equipment to develop games, and receives the user's posture data through the inertial sensor, so there is no need to set up additional cameras, which limits the experience space. Sitting in front of the computer or only staying in a specific space to experience the game, but let the player actually swing the body to make real movements, just like being in the game. We also developed a VR glove. The bending data of the user's finger is received through the bending sensor, and the user's finger is simulated in a VE in real-time. We show its overall hardware and software design.

To derive the advantages between the devices, we performed questionnaires and brainwave experiments. The questionnaire experiment, through the VR cup stacking game, studied the influence of four kinds of devices on measuring the intuitive operation experience in the VE. Furthermore, FSP and SSP show us that the cost of learning bare-hand and hand-worn types of devices is very low for first-time users because people engage in pure hand interactions in their daily lives. This test provides insight into the potential of physical hand interaction to provide an operating experience similar to a handheld device. The results show that the effectiveness of each device depends on the operation types of the VR application. And the scalability of each device, participants rated bare-hand and hand-worn devices as having the potential to provide powerful utility in other VR applications.

We also laid the groundwork for possible combinations of EEG and VR headsets. We used Looxid Link to obtain raw EEG data from participants during the experiment. And modify the original acquire method to label the data under a gesture event. This further helps us analyze different bandwidths under different events. Our results show that, during EEG analysis, participants were more intuitive and relaxed when using Vive Wands in a VE, but Leapmotion has great potential to provide an immersive experience.

In our future work, we will optimize bare-hand and hand-worn devices. We hope to add more themes and develop more interactive VR applications. Because of the difficulty of quantifying this subjective experience, using questionnaires to assess levels of intuitiveness and immersion may lead to inaccurate results. We expect to use brainwave devices to collect wave bandwidth as objective data to analyze the level of intuition and immersion during the experiment. In the future, we recommend conducting this experiment with more participants to reduce noise and use other EEG devices

with more electrodes. It would also be more logical to analyze the data using MNE tools and EEGNN analyzed using machine learning.

# Chapter 6

## Implementation of Interactive Mesh Deformation in between the Virtual and Physical World.

In the context of VR technology, haptics is the use of artificial methods to provide sensory feedback between virtual objects and the user's body, which can be divided into feedback for static physical objects (passive) or physical feedback controlled by electric motor actuators (active). Common haptic technologies are provided to the user through the sensation of the skin or the reaction force of an object can be felt by the muscles. Active haptic feedback technology needs to simulate different types of haptic feedback, resulting in a higher threshold for the size and cost of the input device, while passive haptic feedback depends on the feeling brought back to the user by the interacting object itself. Therefore, this chapter proposes a passive haptic method with our developed VR glove, users can change the deformation of virtual objects by applying force to physical objects with pure hand manipulation, thereby further improving the intuitive interaction experience between virtual and physical worlds.

### 6.1 Introduction

There is consensus that haptic controllers have the ability to provide highly realistic immersive VR experiences [152–154]. Although most of the haptic research has focused on building haptic feedback with motors, electric muscle stimuli (EMS), and pneumatic devices [155–157] the realistic feedback should be generated by the object which is manipulated by the hands of the user. In VR applications, there are many existing studies of bimanual coordinated input technology [152, 158, 159], but only few studies are related to haptic controllers. The majority of previous studies have focused on equipment that is fixed in space and grounded [160]. The movement and degree of freedom of the controller are limited because a physical locking mechanism



is required between the two controllers to provide a sense of stiffness between the hands. This limitation is described in most related works that use grounded equipment. For example, we tried to push, pull, bend, or twist objects which only resulted in them being irregularly shaped. This limitation makes it impossible to render highly dynamic gestures with many degrees of freedom and the deformed state of objects. However, when the left and right hands perform different actions, these are very often seen in real activities. This chapter introduces mesh deformation driven by our proposed VR glove. Unlike setting mechanical or motor constraints on the controller, there is no mechanical connection. Based on Guiard’s conception of asymmetric division of labor in human skilled bimanual action [161], using both hands to operate different flexible objects can still create the tactile illusion. Previous research has shown that our perception of softness relies more on touch than vision [162]. Based on this, simulating the deformation caused by the user’s manipulation of the object is better than simulating the haptic feedback through other mechanisms or motor constraints. For example, various applications such as the fitness ring of the Nintendo Switch [11] and GamesBond [159] have shown that this method effectively brings intuitive and immersive operation and haptic feedback. Our VR glove acquires the data on flexible materials (by bending, twisting, or pressing) through inertia, pressure, and flex sensors set on the glove to render the deformed state of the virtual object. Most commercial VR controllers are limited to providing common manipulation with an input device such as a button, touchpad, keyboard, and mouse. However, to provide intuitive and immersive experiences in the VE, delivering hand manipulation is a key function, which can be observed in HTC Vive, Oculus, and Leapmotion. These pilot VR companies are all targeting this path in the industry. Our proposed method of Haptwarp application is to implement bend, twist, and press manipulations for intuitive interaction between the PW and VW.

## 6.2 Mesh Deformation Implementation

Based on the realization of VR gloves, to further deepen the application of immersion, this research proposes a mesh deformation algorithm that can simulate the deformation of solid objects that users exert pressure through their hands, such as sponges and rubber, which can be stretched, compressed, twisted, and bent. The deformation of flexible objects after being pressed by the user has different characteristics, but the method we propose in this chapter includes confirming the position where the user’s fingertip is exerting force on the virtual object in the VE (scanned through the camera function

provided by Unity). The vertex coordinates of the fingertip touching the virtual object, and how much pressure is applied to the object (obtained from the pressure sensor); after obtaining the coordinates and force acting on the virtual object, we can change the coordinates of other vertices around it according to the magnitude of the applied force to simulate the deformation of the shape being compressed. Another characteristic of a flexible object is the deformation will be recovered to its original shape after being squeezed. Therefore, in 6.2.2, we designed the characteristics of the spring effect and the damping. Spring Effect is mainly to simulate that the object will bounce back to its original state after being squeezed. Damping is to simulate the process of the spring effect, which will gradually stop at a frequency. In addition, in 6.2.3 we explain how to simulate the deformation of virtual objects after being bent and twisted through trigonometric functions.

### 6.2.1 Force Direction

The form of deformation we are trying to simulate is the deformation of the virtual object being pressed or poked by the user. This requires pushing the vertices near the collision point onto the surface. In addition, we observed that the directionality of an applied force is diffusely applied to all directions. This will cause the virtual object's mesh vertices of the facade to be pushed away instead of moving inwards as shown in figure 6.2 (B).

By using the camera object in Unity engine, we can get the 2D coordinate (x, y) where finger tips point and the press direction as the vertical direction (z) as shown in figure 6.1. And the force offset multiplied by  $N_p$  is the level of shrink at that vertex point.

For example, camera object catch the poked point is (1, 1, 0), which means there is no Z-axis depth, we can get the normal direction by using ray function in Unity engine to get the direction of (0, 0, -1), which -1 indicates the direction is pressing down. The purpose to add the direction in position is to let the virtual fingertip understand that we are pressing along with the Z-axis and to let the program change the mesh coordinates to simulate the press deformation effect.

So when we add them together, it is  $(1,1,0) + (0,0,-1) = (1, 1, -1)$ . But -1 is just for the meaning of negative Z-direction, if we use the -1 as the shrink value which is too large, so we give an offset between 0.1 to 0.9 (if directly use 1 or -1 for the value of force offset, the mesh vertex will deform as a planar.) multiply by the value of negative Z-direction for the level of shrink. That is, if the depth change is multiplied by a force direction offset at the force spreading range, it can simulate the displacement range of each vertex after being pressed as shown in 6.2.

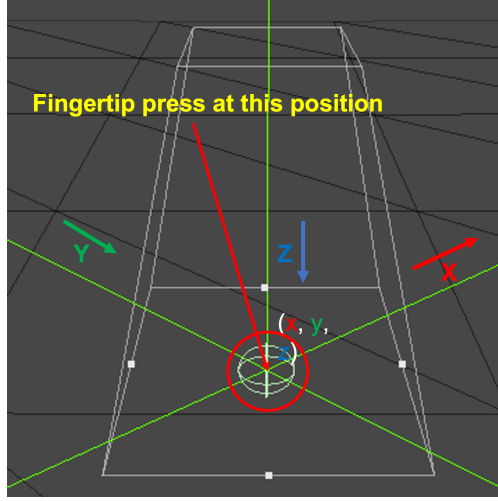

Figure 6.1: Fingertip pression coordinate drawing by raycast in Unity.

Where  $P_d$  represents point with depth,  $P_{poked}$  represents poked point and  $N_p$  represents point along the normal line:

$$P_d = P_{poked} + (N_p \times offset) \quad (6.1)$$

Then, we calculate each vertex with a new depth as shown below, where  $i$  represents the total amount of vertex.

$$P_d(i) = P_d(i - 1) + (P_{poked} + (N_p \times offset)) \quad (6.2)$$

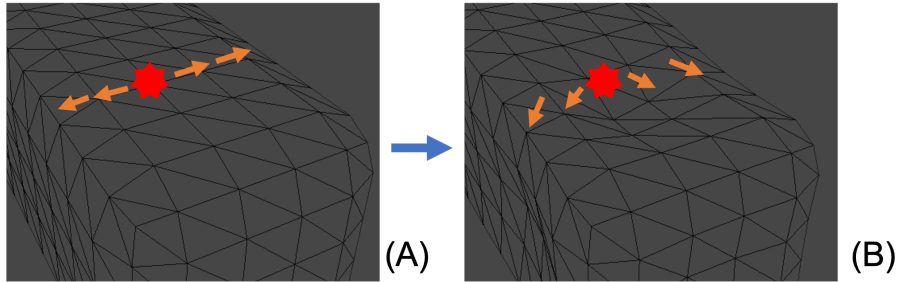

Figure 6.2: Force Direction Offset. (A) represents the force direction before giving offset value. (B) represents the force direction after giving offset value.

### Add Force into Vertex change

The mesh is deformed by an applied force. Over time, the deformation changes the vertices' position as explained in the paragraph below. First,

we need to know the distance between the poked point and the mesh vertex. Where  $i$  represents the number of mesh vertices,  $D(i)$  represents the distance between the mesh point and hit point,  $X_{mV}(i), Y_{mV}(i), Z_{mV}(i)$  represent that mesh vertex on three axes,  $P_{dx}, P_{dy}, P_{dz}$  represent  $P_d(i)$  value in three axes.

$$D(i) = (X_{mV}(i) - P_{dx}(i), Y_{mV}(i) - P_{dy}(i), Z_{mV}(i) - P_{dz}(i)) \quad (6.3)$$

And we understand that the force effect will attenuate until zero with spread distance, and where we can adapt the inverse-square law as equation (6.4). We add one plus the square  $D(i)$  to guarantee that the force is at full strength when the distance is zero.

$$F_a(i) = \frac{force}{(1 + D(i)^2)} \quad (6.4)$$

Now that we have the attenuated force, we can convert it into a velocity to represent each mesh deformation through time. We know Newton's second law of motion  $F = mass \times acceleration$ . And the deforming speed can be derived from the uniform accelerated motion formula  $V = V_0 + acceleration \times Time$ , where  $V_0$  is 0 before the object is poked. So we can get equation (6.5), where  $T_{Step}$  represents the frame time per second.

$$V = \frac{F_a(i) \times T_{step}}{mass} \quad (6.5)$$

Then, we calculate each vertex's velocity as shown below: Where  $V_{vertex}(i)$  represents the velocity of each mesh vertex and  $i$  represents the total amount of vertex.

$$V_{vertex}(i) = V_{vertex}(i - 1) + (D(i) \times V) \quad (6.6)$$

Then, a vertex is updated to its deformed position, through equation (6.7).

$$P_{new}(i) = P_{new}(i - 1) + (V_{vertex}(i) \times T_{step}) \quad (6.7)$$

### 6.2.2 Stay in Shape

After the flexible object is deformed by force, it will return to its original state within a certain time. In our proposed method, there are mainly two methods to achieve it. First, the vertex coordinates of the changed position of the virtual object of the spring effect will be changed and return to the original coordinates in a period. When we give speed conditions, we find that the coordinates will return to the original position and then continue to

move in another direction because we do not let the speed gradually decrease to stop. In order to provide a more realistic for the spring effect, we further propose the damping effect, which simulates the effect of rebound speed from fast to slow until stopping by giving a constant that decreases with time.

### Spring Effect

First, we need to get the distance between the displaced state and the original state. Where  $d(i)$  represents the distance, and  $P_O(i)$  represents the original point.

$$d(i) = P_{new}(i) - P_O(i) \quad (6.8)$$

Then, we assign  $V_{vertex}(i)$  a value that represents the mesh reflection speed of each point.  $V_{freq}$  is used to represent the value of reflection frequency.

$$V_{vertex}(i) = V_{vertex}(i - 1) - (d(i) \times V_{freq} \times T_{step}) \quad (6.9)$$

### Damping Effect

However, the reflection will continue and won't stop, so we need to give a constant  $C_{Damp}$  as a damping property for the object to make sure the speed will decrease until it is stopped.

$$V_{vertex}(i) = V_{vertex}(i - 1) \times (1 - C_{Damp} \times T_{Step}) \quad (6.10)$$

Then, we can feed the new  $V_{vertex}(i)$  back to the equation (6.7) to get the realistic deformation in VE.

## 6.2.3 Bend and Twist Deformation Implementation

Object deformation is not only pressed deformation, but also has the bend and twist deformation. We will explain how to implement them in this section.

### Bend deformation

At the beginning, we need to decide this object's starting deformation point with the lerp equation. However, the length and width in the VE are symmetrical, so we can modify the equation as shown below. Where  $P_{formed}$  represents the start position,  $l_{width}$  represents the mesh width and  $P_{from}$  is an input value from 0 to 1.

$$P_{formed} = \frac{l_{width}}{2} \times P_{from} \quad (6.11)$$

Then, we need to acquire and store each vertex from the original vertex  $z(i)$  to  $P_{formed}$ . Here we use the value  $P_Z(i)$  to represent the original mesh vertex point on the z-axis alone.

$$D_Z(i) = P_Z(i) + P_{formed} \quad (6.12)$$

Once we have the  $D_Z(i)$ , we can calculate each vertex angle of  $\theta(i)$ . Where  $\theta_{Bending}$  represents the input bending angle.

$$\theta(i) = \theta_{Bending} \times \left( \frac{D_Z(i)}{l_{width}} \right) \quad (6.13)$$

Now, we have each bending angle of each vertex, then we need to convert it into radius to get the actual displacement value  $D_Z(i)$ .

$$D_Z(i) = D_Z(i - 1) - 2P_Y(i) \times \sin(\theta(i)) \quad (6.14)$$

We can update the Y coordinate value by adding the displacement of  $D_Z(i)$  to get the correct y position.

$$P_{newY}(i) = P_Y(i) + D_Z(i) \times \sin(\theta(i)) \quad (6.15)$$

We can also update the Z coordinate value by subtracting the  $P_{formed}$  to get the latest position after it is bent.

$$P_{newZ}(i) = D_Z(i) \times \cos(\theta(i)) - P_{formed} \quad (6.16)$$

In the end, the latest updated position will be like as below:

$$\begin{bmatrix} P_{newX}(i) \\ P_{newY}(i) \\ P_{newZ}(i) \end{bmatrix} = \begin{bmatrix} P_X(i) \\ P_Y(i) + D_Z(i) \times \sin(\theta(i)) \\ D_Z(i) \times \cos(\theta(i)) - P_{formed} \end{bmatrix} \quad (6.17)$$

### Twist deformation

Twist deformation is a typical deformation in physical objects. We will now explain how to implement this in a virtual object. In equation (6.18), we can convert the input twist angle into an angle value. Where  $\varphi$  represents the scale value which is related to the size of the virtual object.

$$\theta(i) = \left( \frac{P_Z(i)}{\varphi \times \theta_{Twist}} \right) \quad (6.18)$$

We can then update the x position value by adding the correlation value of y and further update the y position by subtracting the correlation value of

x to simulate the twist deformation on the virtual object. Since the twisting object won't affect the length of z, the z position is kept the same as the original value.

$$\begin{bmatrix} P_{newX}(i) \\ P_{newY}(i) \\ P_{newZ}(i) \end{bmatrix} = \begin{bmatrix} P_Y(i) \sin(\theta(i)) + P_X(i) \cos(\theta(i)) \\ P_Y(i) \cos(\theta(i)) - P_X(i) \sin(\theta(i)) \\ P_Z(i) \end{bmatrix} \quad (6.19)$$

Finally, we can reveal these three deformation bases on the deformation algorithm as shown in figure 6.3.

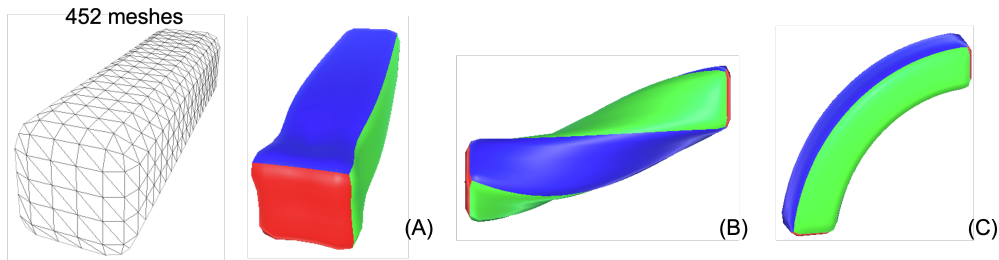

Figure 6.3: Rounded Cuboid Deformation: (A) Pressed Deformation (B) Twisted Deformation (C) Bend Deformation

## 6.3 Applications

To further illustrate the utilities of VR Glove, we developed three VR applications using Unity 3D and categorise them into three categories: (1) the illusion of pressing, (2) the illusion of bending, and (3) the illusion of twisting. The VR glove's ability to provide intuitive hand manipulation and generate a realistic haptic sensation for a dynamic and deformable object is showcased effectively in the application. As shown in figure 6.4, the user can excute a variety of deformation illusions such as sponge and rubber with hand manipulation.

## 6.4 Conclusion

The earlier limitations are related to the precision of force detection and the complexity of object deformation in VE. There are several trade-offs associated with using five pressure sensors to render the deformation of a hand-held object, despite its simplicity. The utilization of five pressure sensors to capture hand-held object deformation is a straightforward approach,

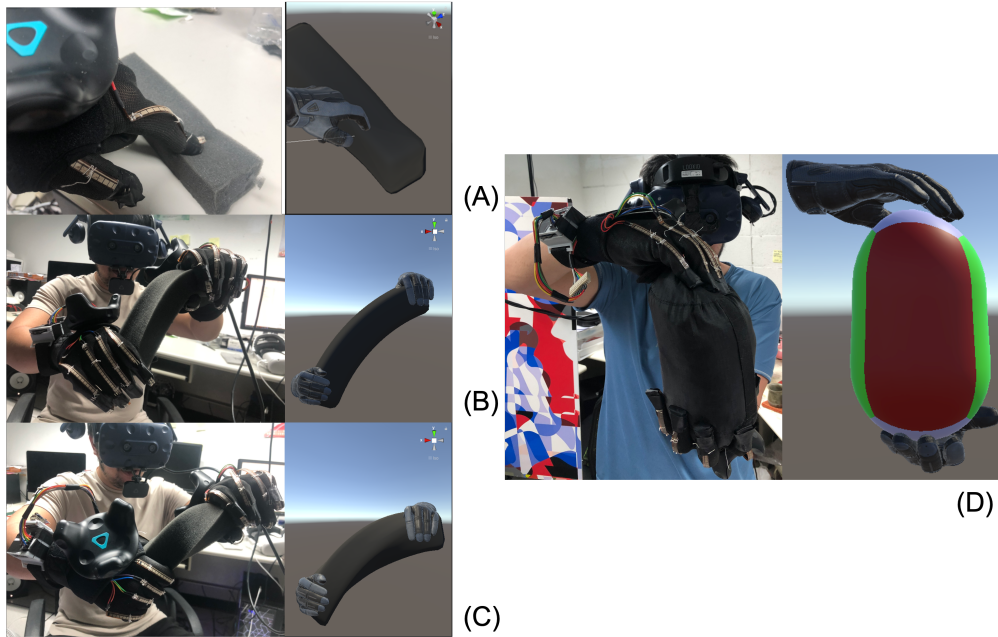

Figure 6.4: Demonstration of illusion deformation in between virtual and physical world. (A) The illusion of pressing, (B) The illusion of bending, (C) The illusion of twisting, (D) The illusion of squeezing.

but it comes with certain drawbacks. The detected force's minimum and maximum ranges are restricted, and the force applied on the fingertip is uneven, depending on the direction of the pressing action. The flex sensor is quite useful to detect the finger bending angle, but as we know, the finger consists of three bones, but the sensor can only detect the angle of the end bone. For the current solution, we simulate the other two finger-bone movements with single sensor data by using simple linear equations. The algorithm used in our study only considers rubber and sponge parameters to simulate the visual feedback of the object deformation. However, it may not be possible to realistically render more complex object deformations, and a polyhedron could make the deformation algorithm ineffective. One solution to address the limitations of using only five pressure sensors to detect hand deformation could be the use of a stretchable PCB technique. This approach would involve attaching force sensors and flex sensors to key locations on the hand to capture more detailed and accurate data on hand movement and deformation. Furthermore, we expect that by adopting free-form surface deformation [163] and customized per-vertex stiffness map [164], we will be able to simulate deformation for customized mesh data in a VE (stiffness and



properties). Finally, the finger calibration method can occasionally generate value, creating an unrealistic sensation. Future work will explore various tasks that fit everyday life as well as explore the effect of different hand-held objects. Theoretically, the VR glove could include multiple sensors to generate haptic feedback.

In conclusion, in this chapter, we introduced the VR glove, capable of creating the illusion of object deformation. We presented the overall hardware, and PCB design and described how to press, bend, and twist deformations can be simulated.

# Chapter 7

## VR Integrate with Companion Doll

For a social robot to effectively engage with users, it is important that its communication feels natural to humans. To achieve natural and efficient communication, robots must be able to perceive and handle multimodal information, such as inputs, outputs, and respond appropriately. Therefore, designing interactions in VR plays a crucial role in developing immersive and captivating multimodal experiences. These interactions need to be intuitive enough to not break the immersive experience during the interaction in aVE, but should also be easy to understand. In our research, we present a companion doll based on the design of continuum tail mechanisms and a corresponding virtual avatar in Unity. It can provide vivid tail movements under different emotions activated through continuous gestures through our proposed VR glove. To validate the effectiveness of the proposed system we conduct a questionnaire and electroencephalography (EEG) signal analysis. The result shows us our proposed system can improve the interactive and immersive experience for VR interaction.

### 7.1 Introduction

Social robots are designed to communicate with people for basic social interactions with different sensors set up to sense and respond to human behavior in the environment [165]. Compared with general robot design, social robots involve more social environments and how to communicate with humans in daily life to provide effective help [166]. They are often called as companion robots and are designed to create a sense of companionship by interacting with people in their daily lives, providing intuitive, expressive, and emotional feedback. To be incorporated into daily life, companion robots require specific design features that meet user expectations. As with other types of social robots, the design process must understand its environment, interaction type, and function to categorize its application attributes [167].

First, observe the environment in which the robot is placed, design corresponding interaction types according to different environments, and develop corresponding functions based on the interaction types. Different companion robots can be classified through the study of many literatures. In terms of environment, companion robots can be used in various environments such as elderly care in the medical field, assistance for the disabled, counseling for mental illnesses, and cognitive therapy [168]. Educational places such as teacher-student interaction assistance in the class, occupational interaction training assistance, etc. Therefore, the design of portability is very important. In terms of interaction modes, gesture recognition can have broader features, such as bringing gesture interaction commonly used in real life into human-computer interaction through stroking or hugging [169]. On the contrary, the companion robot can also provide different sensors such as body part swings, facial expressions, pneumatic feedback, vibration feedback, etc. to increase the fun and immersion of the interaction [170]. Further integration of VR technology provides deeper visual stimulation to expand more application aspects. Finally, the corresponding application is designed according to the interaction that the companion robot can provide. For example, Pepita [171] is designed to interact with the user to express emotions through gesture recognition and projection screen. Blossom [172] provides users with visually vivid effects through the interaction of motors and pneumatic devices with animation. Buddy [78] is specially designed for human-robot interaction (HRI), enabling it to detect and recognize different shapes through 2D and 3D cameras to sense the human presence, respond and assess their ability to engage. Early work by Lee et al. [173, 174] included the development of interactive companion dolls to provide intuitive manipulation of objects and motor-driven feedback in VE and RE, allowing users to perceive not only visual and acoustic feedback, but also the relevant motor drive feedback is sensed during the experience. However, emotional effects are a complex system with different conditions activated by different stimuli. Currently, it is a challenge to provide emotional feedback in VE by simulating caress, finger punch, flap, etc while controlling the physical companion doll to display the corresponding reactions, there is no such interactive interface that can simulate all natural behaviors to provide a variety of interactions. Most works developed for interactive dolls can only provide one-way communication between player and audience, or only support interaction in VE or RE. To enhance the immersive experience of VR systems, we propose BOBO, a companion robot designed to interact with the user's continuous gestures and provide corresponding physical and virtual feedback. Using the VR glove developed in this paper to simulate and acquire gesture data in real-time to transfer to VR. The system consists of

an interactive companion doll and a virtual interface developed in Unity. Through this system, users can interact with a virtual companion doll through a persistent gesture recognition system based on the concept of three emotions (happy, sad, and disgusted), activating three emotions in a virtual scene. At the same time, the user can also feel the feedback of the motor drive when interacting with the companion doll. The main contributions of this study are summarized as follows. First, we developed a motor-driven tail mechanism model with six emotional movements (happiness, sadness, anger, fear, surprise, and disgust) to provide real feedback from virtual scenarios, and conducted user studies to evaluate the prototype that can help us improve the design of the continuous tail structure. Second, we built an immersive VR application that allows users to interact with companion dolls in six emotions to explore gestures and user feedback between observing dolls' different emotions. Third, based on the first and second results, we modified the immersive VR application to allow users to interact with companion dolls in the virtual and real worlds. Finally, we design a questionnaire and EEG experiment to cross-investigate the experience and feedback from users to further validate our proposed system. This study will aid in the development of robotic devices for comparable use cases in the future.

## **7.2 The process of designing BOBO**

### **7.2.1 Motor-Driven based Tail Mechanism**

In nature, most animals' tails help them to balance, move forward/backward, and even represent their emotions [175]. This section aims to review previous research about the design and implementation of robotic tails which contain inertial adjustment ability classified by structural design and methods of operation.

#### **Linkage Tail Mechanisms**

Before we decide to develop a motor-driven based mechanism for our research, we've searched several designs of robotic tails. In the beginning, we found that the TAYLRoACH [176] (Tail Actuated Yaw Locomotion RoACH) maintains a single-body rigid pendulum-like tail, which is a small robot with a 4gram, 11.5cm tail driven by a custom gearbox and a DC motor. However, this kind of tail design normally is for balancing the device which is not suitable for our research because it's hard to simulate real tail movement in RE. A different type of design is the linkage-based tail mechanism. Kohut

et al [177] proposed a prototype that aims to simulate undulatory motion by the tuna fishtail peduncle and caudal fin. Hence, the tail mechanism has the benefit that plays a determining role in the dynamic behavior of the robot.

### **Articulated Spatial Tail Mechanism**

For the typical design of articulated spatial tail mechanism, Saab et al [178] proposed a novel robot tail design, which can be divided into three sections in total.

The rolling freedom at the front side allows a single structure to roll in space and drive the tail section to perform different functions.

The two parts of the rear section, it has two independently driven coplanar bending sections, which are composed of multiple links connected by rotating joints to provide more freedom of swing and can simulate more vivid tail movements. However, due to the connection of each bone segment was inserted with pins limited the degree of freedom for separate bone's movement which means if the tail mechanism is in a small size, it's hard to simulate the vivid movements.

### **Continuum Tail Mechanisms**

To move forward to another type of tail design.

By using soft and flexible materials to build a tail mechanism have the characteristic of continuous curvatures and low joints by comparing with articulated spatial tail mechanism. Rone et al. [179] proposed a continuum tail mechanism which was composed of eight disks and mounted along with an elastic bar which can be driven by four tensioned cables and disks. This kind of design without using pins to connect each bone segment which means there's no restriction for individual bone's moving direction and more suitable for small size of tail mechanism.

The appearance of cartoon robots is simpler and can be expressed in a unique way [180].

The home environment is often considered as an ideal setting for this type of robot.

We believe that not only can it be placed in the home environment, but more application areas can be reached through the integration of VR technology, and the appearance of cartoons is more suitable for the design of BOBO to increase the anticipation of its interaction with users.

## Initial Prototype

In many research mention that the movements of an animal's tail are indicative of its emotional state [181]. In our study, we aim to implement the tail movement with mechanical device.

To find the cognition in-between emotions and tail mechanism expressions, further validate the hypothesis, we made the first prototype as shown in figure 7.1 (a). Be aware of the tail part. It consists of 11 segments connected with steel pins and there are no gaps between each segment, which restrict the mobility of tail movement.

As the second stage, we extend the gaps for each segment through cut hollow hoses to extend its mobility as shown in figure 7.1 (b).

For the electric hardware part, it consists of a WeMos mini D1 mini with a power supply, two servo motors setup in the 3D printed case.

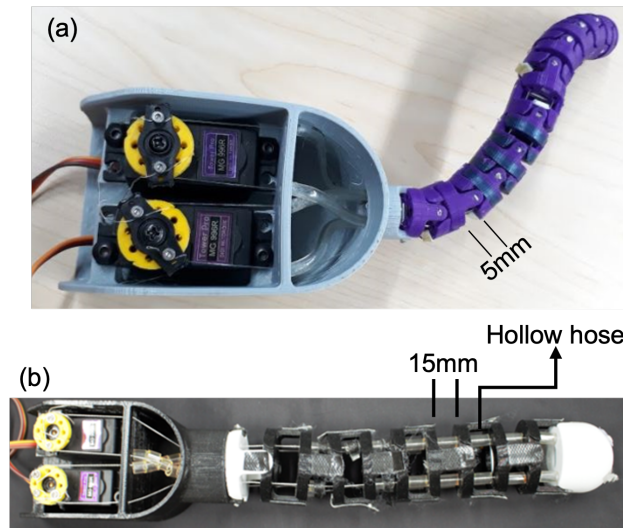

Figure 7.1: Development History

In the beginning, we refer to the tail movement when animal under six different emotions and build similar movements with the prototype and record videos for each movement as shown in figure 7.2.

We presented the videos to 27 people and showed the six tail mechanism wagging videos to them to investigate which movements are related to which emotions. As the results display in table 7.1, we realized that using this kind of structure is hard to deliver real animal emotions for people since its limitation of degrees of freedom (DOF) as shown in figure 7.3 and equation (7.1). The disadvantage of using a hinged design is that each tail of the part has only one DOF (rotation around one axis) and the DOF of a kinematic

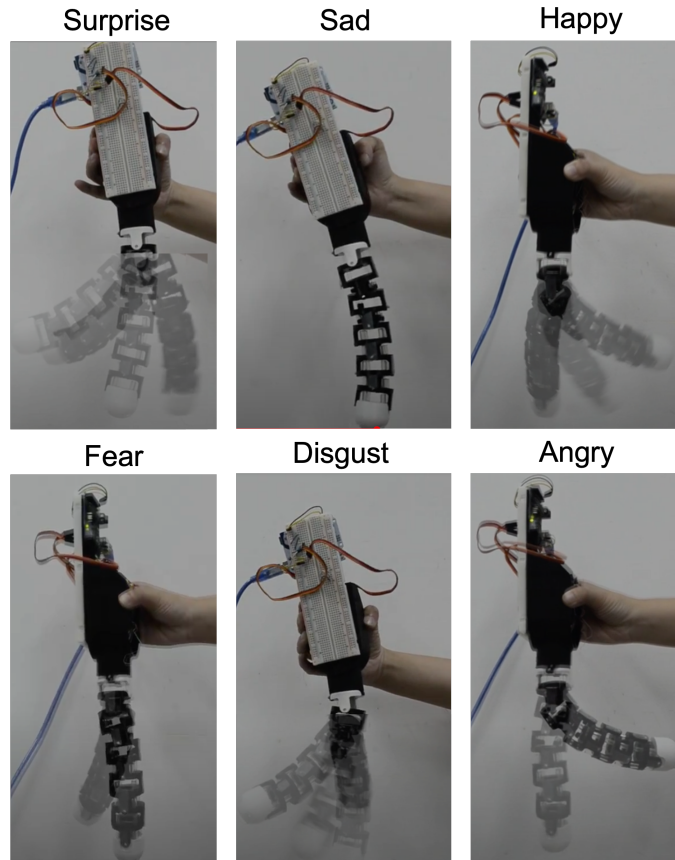

Figure 7.2: Six emotional tail movements display with the prototype.

link can be calculated using Grubler's Rule ( $DOF = 3 \times (N - 1) - (2 \times L) - H$ ). Where N means the total number of components, L means the number of lower pairs and H means the number of higher pairs. In our case,  $N=2$ ,  $L=1$ , and  $H=0$  will get the  $DOF = 1$  which means the design of the tail mechanism only allows rotation around one axis in each segment as shown in figure 7.3.

$$DOF = 3 \times (2 - 1) - (2 \times 1) - 0 = 1 \quad (7.1)$$

### Improvement Design

The circuit of the BOBO companion robot consists of a circuit board connecting a WiFi-enabled control board (Wemos D1 mini) and a power module to drive two servo motors. The circuit board and two servo motors are mounted on the printed motor base. The motor base is connected to a printed hollow semicircular shell as the head bone. The Vive Tracker is

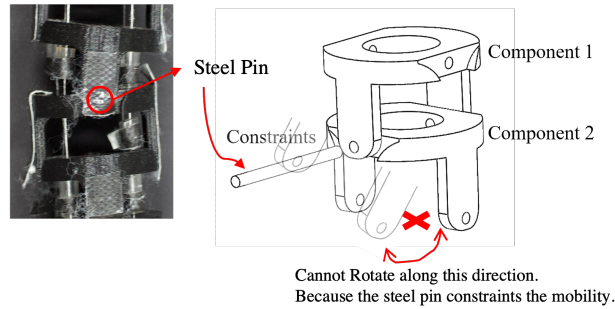

Figure 7.3: Sketch of Tail

Table 7.1: Investigation Result

Videos	User feeling					
	% of Hap	% of Anger	% of Sad	% of Fear	% of Surp	% of Dis
Anger	7.4%	14.8%	14.8%	22.2%	29.6%	11.1%
Happiness	85.2%	3.7%	0%	0%	3.7%	7.4%
Sadness	3.7%	18.5%	33.3%	29.6%	11.1%	3.7%
Fear	7.4%	22.2%	25.9%	7.4%	18.5%	18.5%
Surprise	22.2%	14.8%	11.1%	7.4%	14.8%	29.6%
Disgust	37%	11.1%	11.1%	14.8%	14.8%	11.1%

connected to the top of the head bone to allow the lighthouse (HTC infrared emitter device) to accept the position of the robot in real space. The control board mainly receives the values sent by the computer to control the actions of the two servo motors. To move forward to vivid simulation, in the tail mechanism part, a plurality of wires are fixed at each end of the cantilever of the servo motor. The use of multiple wires can ensure durability and stability. Six printed discs of decreasing size are connected in series through the motor base to form a tail-like skeleton as shown in figure 7.4.

### 7.2.2 Tail Movements and Emotion feedback of BOBO

The design of BOBO has two primary functions: firstly, it employs VR technology to enhance the robot's facial expressions and its application in various environments, and secondly, it employs data gloves and motion-sensing devices to enable interaction with the companion robot and facilitate



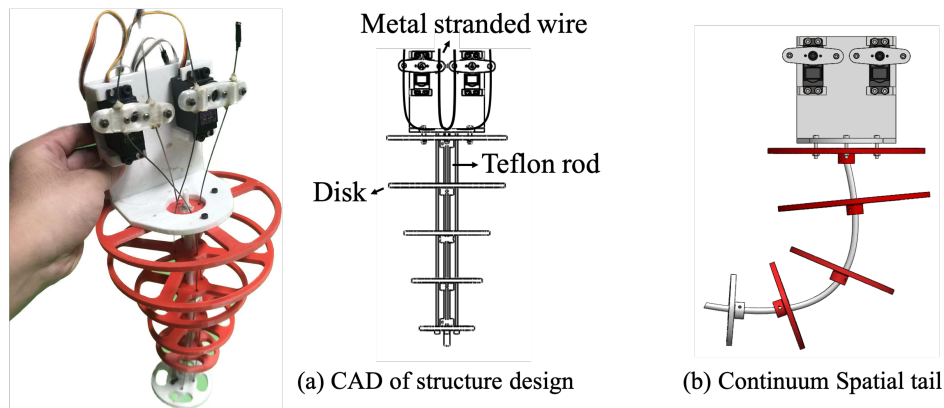

Figure 7.4: Continuum Design

emotional expression between the user and the robot.

### Affective Expressions Using VR Technology

Various studies on HCI have investigated ways to enable robots to convey emotions, as reported in previous works [80]. These studies have explored a range of options, including robots with mechanically expressive surfaces, as well as those utilizing animated faces or avatars. Each approach has its own advantages and disadvantages, and the choice of technique depends on the intended purpose of the robot's expression. For example, it was found that a robot with a cartoon appearance would have a positive effect on the user's comfort [83]. However, at the same time, it is more difficult to recognize emotions than using real humanoid representations. Emotional expressions can also be conveyed by robots with a simpler appearance using body movements or colored lights. Research has shown that dynamic colored lights, in combination with sound and vibration, have been used as a simple and cost-effective way to express robot emotions [182]. While this method can be effective for constrained robots, it has limitations in conveying detailed information due to the abstract nature of color light patterns.

One possible solution is to combine robots with VR equipment [183]. In particular, positioning based on built-in cameras such as Oculus Quest2 and Vive Focus2 brings lower space constraints to portable robots. In the past, through the analysis of changes in projectors, lights, and drive motors, the potential was as a tool for emotional expression of machines [171]. Most companion robots based on emotion research usually provide a physical way to express the emotions of the robot with a projector or a deformable mechanism [184]. There are a few related kinds of research on the use of VR

technology to provide additional visual information channels to supplement the limited ability of robots to express emotions. However, we can explore some emotional behaviors from the interaction between some VR users and robots. Therefore, we must first explore the user’s impression and perception of the robot that interacts through VR technology.

Based on this, our research group is trying to provide a new interface for interactive robotics between virtual (VE) and real environment (RE).

In addition, we also designed a virtual avatar with a cartoon-animal-like appearance (more acceptable by people) for the physical tail mechanism as shown in figure 7.5. Compared with the physical dolls expressing emotions by changing facial details through motors, the virtual expressions we designed can convey more realistic emotional feedback.



Figure 7.5: The emotions designed for the virtual avatar

### Sensing Tangible Affective Expressions

When a robot can display artificial emotions, another aspect of the design is how it interacts with the user [83].

The role of body movement is artificially important for expressing emotions. In human-to-human communication, positive emotions can be conveyed to others only by touching, hugging and other actions, and negative emotions can also be conveyed by tapping or pushing [185].

Hugs are a significant aspect of human communication among the various actions. According to Lhommet (2014) [186], hugs are a significant aspect of human interaction as they communicate comfort and emotional connection. Design approaches that focus on mediating intimacy and relatedness have been found to be effective in conveying emotions through gestures.

Prior studies have investigated the advantages of computer-mediated communication through huggable interfaces, and results have demonstrated

that contact with a mediator can have positive effects on individuals, including reducing mental stress [171].

To detect a user’s hug, robots with large embodiments use an array of pressure sensors positioned around the robot’s body. By measuring the pressure applied at different points when the user hugs the robot’s body, the hug can be detected and recognized [187].

Stiehl et al. [188] designed a small teddy bear-like robot whose body is covered with a soft material and has a built-in pressure sensor. However, the current design of the robot does not allow it to differentiate hugs from other types of physical interaction that involve pressure or stress.

Nho et al. [189] developed a mobile robot that can convey different emotions through user gestures.

Based on the literature mentioned, emotional interaction plays a crucial role in the communication between users and companion robots. The design of most companion robots features a non-humanoid appearance that resembles cartoon animals.

Therefore, in this section we use the previously proposed VR data glove and continuous gesture recognition method as a tool for users to communicate emotionally with companion dolls.

## 7.3 Experiment Design

To understand user feedback, the design of a questionnaire to collect exploratory information for better understanding the validity of the proposed system [190]. On the other hand, we may acquire subjective feedback from users due to personal relationships or any other privacy issues. To avoid that, we also design an experiment by using an EEG device to acquire the user’s brain wave for the objective evaluation [61]. Conducting questionnaires and EEG signals to get convincing feedback is important to validate our application.

### 7.3.1 Questionnaire Overview

In the experiment described next, we compared the effect of digital avatar with the effect of physical avatar when they were used to convey the robot’s affective expressions. To evaluate the use of avatars in this application, we design two questionnaires refer from [15] for the users to fill out after the experiment. We recruited 15 participants aged from 23 to 27 years old who were not familiar with the robot (8 males and 7 females) and took this questionnaire. In the upcoming experiment, we conducted a questionnaire

to understand how the participants perceived the robot’s embodiment. To avoid confusion between the two embodiments used in the study (physical robot and projected avatar), we asked participants to specify which entity they perceived as conveying affective expressions. In the past, researchers have explored using multimodal interfaces with different embodiments, such as avatars and physical robots, to enhance the user’s experience. These studies highlight the importance of ensuring that users perceive the same entity regardless of the embodiment used. For example, one study used a migration system to switch between a physical robot and an avatar with a similar appearance to maintain a consistent perception of the entity [191]. Similarly, another study explored user perception when interacting with an artificial pet with two different embodiments that switched between them, ensuring that only one embodiment was active at a time [192]. To understand the perception of the robot embodiment, the researchers included one final question in the questionnaire. Since both the physical robot and the projected avatar were active simultaneously, they asked participants to choose the statement that best reflected their perception of the robot body interface as follow.

- Q1.** I found the interface are easy to understand.
- Q2.** Once I understood the gestures, I found the interaction to be easy and intuitive to use.
- Q3.** I prefer the glove manipulation to a mouse and keyboard interface.
- Q4.** I perceive the robot body interface as two entities: an avatar and a robot.
- Q5.** I perceive the robot body interface as one entity: the robot and its avatar.

### **7.3.2 Evaluating User Cognition in an Interaction with Virtual & Physical Doll Using EEG**

Six EEG channels were measured using the LooxidLink [64] device, cover at the frontal region of head (see figure 7.6) and was sampled at a 500Hz sample rate (provided by LooxidLink EEG device) with nodes (AF3, AF4, AF7, AF8, FP1, FP2) and fitted on the HTC Vive Pro HMD system as shown in figure 4.5 (a).

To acquire the baseline brain wave data, 10 participants aged from 23 to 27 years old were asked to sit and look at the computer without any head movement and remain still in the pose for a minute to get the baseline brain wave data of eye-open without performing the task (EO w/o task). We set up two conditions for the participants to interact with BOBO, the first condition

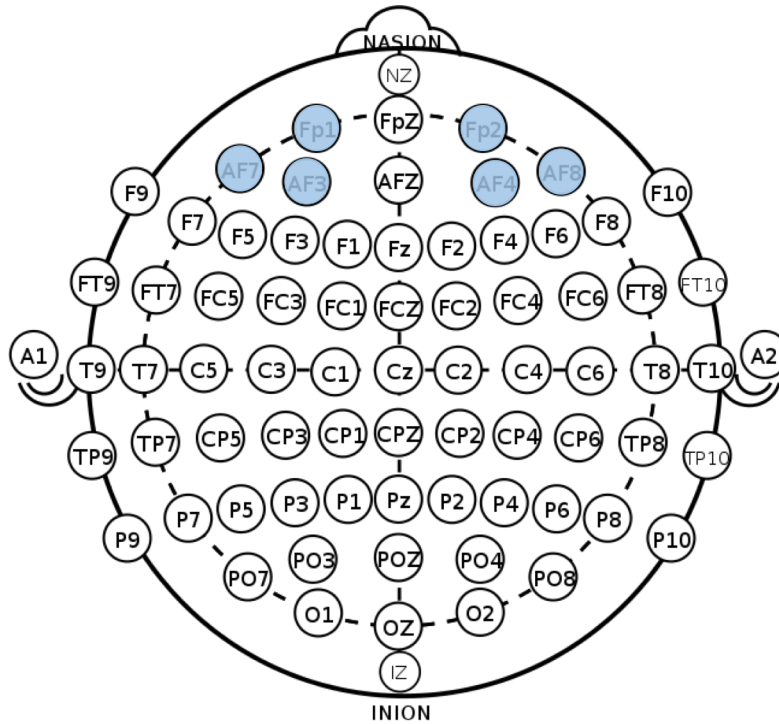

Figure 7.6: International MCN electrode system. Looxid Link is able to extract AF3, AF4, AF7, AF8, FP1, FP2 electrodes.

is the virtual avatar’s emotional feedback only be displayed on a 2D screen (2DS), and the other is to let participants wear the HMD to feel the emotional feedback from the virtual avatar at the artificial virtual 3D scenario (V3S). During the EEG data acquisition process, the 2DS task and V3D task were taken approximately 1 minute and 30 seconds after the participant’s EEG had stabilized during the immersive task. We collected prefrontal brainwave data (AF3, AF4, AF7, AF8, FP1, FP2) from 10 subjects interacting with BOBO in three states (EO w/o task, 2DS, V3S). To effectively analyze the density of the Alpha wave and Theta wave of each electrode (Alpha related to the focus state of the user and Theta indicates the relaxed state of the user) due to these two bandwidths related to the intuitive and immersive experience, EEG signals were filtered while the values larger than 0.5, smaller than -0.5 and the value equal to 0 remain the valid signals. Then, we take the average EEG signal value of each channel to draw the power spectrum diagram. Once we have the diagram, we can extract the power of each bandwidth, especially the alpha power and theta power To calculate the power of alpha and theta waves from EEG data, we need to determine the area under the wave. This cannot be done analytically, so we use the composite Simpson’s

rule to approximate it. This involves breaking the area down into parabolic sections and summing their areas. Other methods, such as using trapezoids or rectangles, could also be used, but parabolic sections tend to give a more accurate estimate. In Python, the composite Simpson’s rule is provided as a built-in function.

## 7.4 Results

We attempted to answer three inquiries related to the robotic device based on the responses gathered from the questionnaire presented in table 7.2. The first question tried to determine whether the interaction is easy to understand or not. The results showed seven people select agree, three people select strongly agree, three people didn’t have that feeling and two people do not think it is easy to understand. For the second question, six people select agree, five people select strongly agree, three people didn’t have that feeling, and one person hard to perform the correct gesture. For the third question, ten people select the agree, three people select the strongly agree, and two people think the glove is not much different from the desk input device, however, there are no participants who think the mouse and keyboard are better than the glove. Regarding the concept of digital twins, thirteen people think the virtual avatar is just like the physical doll while playing the VR application.

Table 7.2: Result of the Questionnaire

Feeling of the interaction with VR glove					
	Strongly Disagree	Disagree	Normal	Agree	Strongly Agree
Q1	0	2	3	7	3
Q2	0	1	3	6	5
Q3	0	0	2	10	3
User’s perception while interacting with companion doll					
Q4	2		Q5	13	

Figure 7.7 shows the overall EEG power spectrum for three conditions in six EEG channels AF3, AF4, AF7, AF8, FP1, and FP2 representing frontal regions. Compared to the baseline EO w/o task condition, both the VR interaction and the 2D screen interaction measured the same fluctuation in delta activity. The highest activity in the theta band was observed under V3S conditions. When it comes to the Alpha band, there is a similar reduction in V3S condition and 2DS condition in different channels. Under the three

conditions, in the Beta band, except for the AF8 channel that fluctuated during V3S condition, the rest of the channels gradually decreased and continued to the later Gama band.

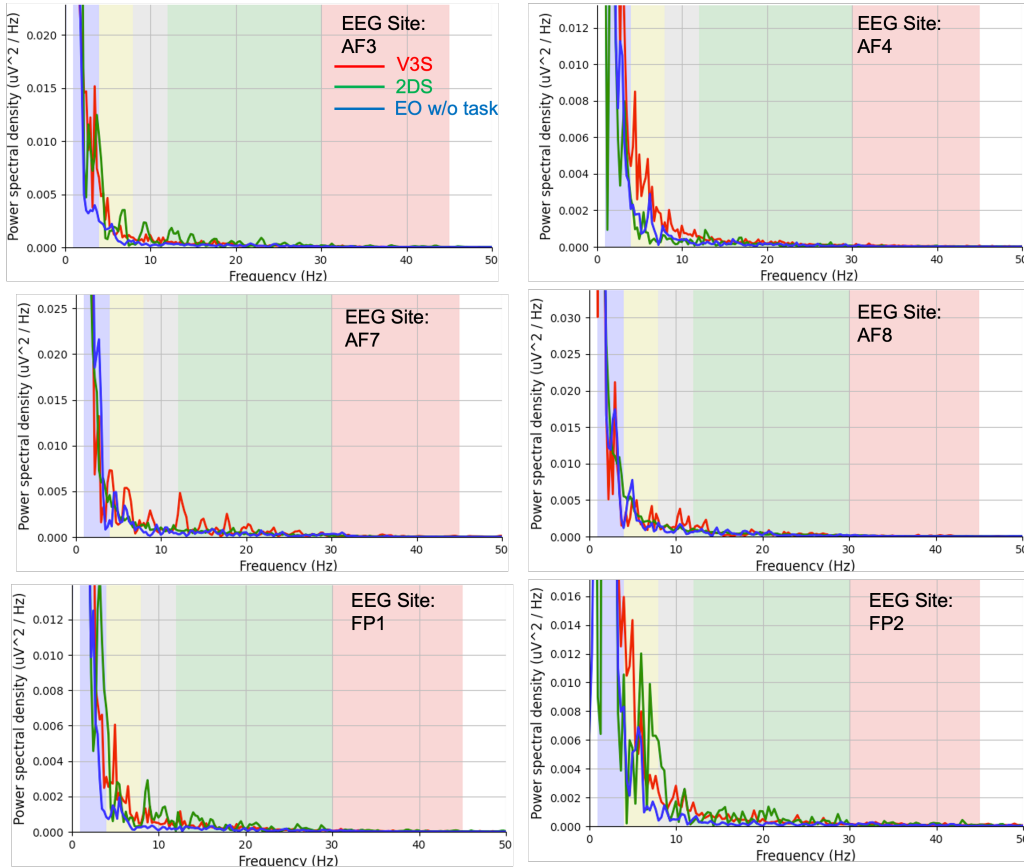

Figure 7.7: EEG average power spectrum for 10 participant during eyes-open without performing task (EO w/o task, blue line), two-dimensional scree (2DS, green line) and virtual 3D scene (V3S, red line) in the AF3, AF4, AF7, AF8, FP1 and FP2 channels. Blue shade = Delta (1-4 Hz), Yellow shade = Theta (4-8 Hz), Gray shade = Alpha (8-12 Hz), Green shade = Beta (12-30 Hz) and Pink shade = Gama (30-45 Hz).

## 7.5 Conclusion and Discussion

In the past, the interaction of VR only focused on the content design of the VW [193]. Currently available controllers or interactable devices can

only provide one-way communication, and often fail to achieve a satisfactory sense of immersion and intuitive operation.

Table 7.3: Alpha & Theta Power in six EEG sites for the three conditions.

Channel	BandWidth	Three Conditions		
		EO w/o Task	2DS	V3S
AF3	Alpha	$0.001uV^2$	$0.003uV^2$	$0.003uV^2$
	Theta	$0.005uV^2$	$0.010uV^2$	$0.008uV^2$
AF4	Alpha	$0.002uV^2$	$0.001uV^2$	$0.003uV^2$
	Theta	$0.005uV^2$	$0.003uV^2$	$0.012uV^2$
AF7	Alpha	$0.002uV^2$	$0.004uV^2$	$0.005uV^2$
	Theta	$0.008uV^2$	$0.008uV^2$	$0.012uV^2$
AF8	Alpha	$0.004uV^2$	$0.004uV^2$	$0.007uV^2$
	Theta	$0.011uV^2$	$0.012uV^2$	$0.011uV^2$
FP1	Alpha	$0.001uV^2$	$0.004uV^2$	$0.002uV^2$
	Theta	$0.003uV^2$	$0.006uV^2$	$0.007uV^2$
FP2	Alpha	$0.002uV^2$	$0.007uV^2$	$0.007uV^2$
	Theta	$0.013uV^2$	$0.024uV^2$	$0.027uV^2$
Means	Alpha	$0.002uV^2$	$0.004uV^2$	$0.005uV^2$
	Theta	$0.0075uV^2$	$0.011uV^2$	$0.013uV^2$

In this study, we explore a way of virtual-real interaction that integrates VR with companion robots and glove input devices to improve user interaction with virtual content. Our questionnaire survey results show that most users rate this interface very positively, and believe that a doll that can interact in both the VW and PW can help improve users' intuitive operation and immersion in the VE. The results of the brainwave analysis found that for users interacting with dolls in a 3D virtual scene, compared with other bandwidth, the theta is the most obvious. In the table 7.3 it can be observed that among all channels, the intensity of the theta band of the user in the 3D VR scene is the highest, which indicates that when the user interacts with the virtual content using our device, compared to the usual and 2D screen interactive scenes, it can be in a state of focusing on interacting with virtual dolls in the VE. There is no significant difference in alpha strength between almost all EEG sites on 3D VR and 2D screens, which means that the user is actually in a relatively relaxed state interacting with the companion doll in either scenario. According to a study by Naves et al. (2021) [194], changes in EEG alpha power, as well as increases in delta and low gamma activity, could be attributed to the "distraction" or immersive effects of VR applications, with 3D VR being considered the most immersive form. This



chapter presents BOBO, a companion robot created to detect and express emotional information. The current interface is used for implementing long-lasting gestures that can interact with both virtual and physical robots. These lifelike gestures are translated into visual feedback on projected avatars that convey positive emotions (such as happiness) and negative emotions (such as sadness). The chapter covers the development of the robot, the system's overview, an assessment via a questionnaire, and analysis of EEG signals. This research represents the first step in the process of developing companion robots for virtual-reality interaction. The future work on BOBO will involve making the robot's appearance more similar to familiar huggable elements, such as stuffed animals or cushions, by adding a set of fluffy looks that initiate and support natural hugging behavior. Additionally, a variety of sensors will be added to facilitate the development of more somatosensory interaction functions.

# Chapter 8

## Conclusion and Future Work

### 8.1 Conclusion

VR creates a three-dimensional digital environment that provide the potential to immerse the user in a VW that either closely replicates reality or completely detaches itself from reality. A person experiences VR the same way they experience actual reality. They are surrounded by a VE and can interact with that environment in a way that mimics real-world experience. Based upon the proposed NHED model, this research implements the reality experience in virtual. Natural interaction in VR can facilitate the intuitive experience of the VW. Providing users with human factor feedback on interaction information can help develop and share their behavior, further understanding how the system works and how user behavior affects its performance. Simultaneously, embodiment sensations and double-bridge avatar in VR can also facilitate the acquisition and enhancement of mind-body relationships and social interactions and behaviors. These capabilities make VR a powerful learning and communication tool by providing an intuitive and immersive experience.

#### **MRQ: How to match between the physical movement and visual feedback in the VE?**

This dissertation presents a systematic methodology integrating software and hardware to improve intuitive operation and immersive experience in VR applications. The proposed approach includes the exploration and improvement of input devices, tactile feedback, and interactive dolls, and provides a detailed description of the construction process from conception to project approval. The dissertation also evaluates the effectiveness of the proposed system through the development of software and hardware and the analysis of subjective and objective data, providing a replicable case for related research in the field of VR interaction.

The impact of this research lies in its contribution to the development of a systematic methodology integrating software and hardware to enhance

the intuitive operation and immersive experience of VR applications. By exploring and improving input devices, tactile feedback, and interactive dolls, the proposed approach provides a detailed description of the construction process from conception to project approval. The evaluation of the proposed system through the development of software and hardware and the analysis of subjective and objective data provides a replicable case for related research in the field of VR interaction.

The proposed methodology and findings of this research have the potential to inform the design and development of more effective and user-friendly VR applications, enhancing users' engagement, satisfaction, and overall experience. The development of effective VR technologies has wide-ranging implications across numerous domains, including education, entertainment, healthcare, and engineering. By advancing the state of the art in VR interaction, this research has the potential to enable the creation of more immersive and engaging VR applications that can better meet the needs of users in various domains.

### **SRQ-1: How to achieve the intuitive manipulation?**

As stated in Section 1.4.1 of this dissertation, intuitive manipulation in VR refers to the ability of users to interact with virtual objects in a way that feels natural and intuitive based on their prior experience and knowledge of the physical world. Some key strategies for enabling intuitive manipulation in VR include: (1) using natural and familiar gestures and movements, such as reaching out with a hand or other body part to touch or grasp a virtual object; (2) providing clear visual cues and feedback to guide users, such as highlighting selected objects or giving information about their properties; (3) designing an easy-to-understand user interface with intuitive interaction that is consistent across different VE. Among them, the hand is the most important tool for interacting with the VE, and they should be able to perform the most critical tasks. However, the available input devices for VR experience do not match the natural behavior of humans, resulting in a gap in intuitive interaction. In Chapter 4, a motion tracking device and VR gloves are developed to provide natural gestural behavior, and an algorithm for recognizing continuous gestures. The recognition results of each static gesture are inserted into a real-time updated sequence, and experiments are performed to reveal the recognition rate of each combined gesture. The proposed system improves the intuitive interaction experience of VR applications by recognizing 15 different types of gestures using motion tracking and VR glove technology. Data collected from forearm swing and finger flexion were analyzed using an example-based sensor prediction (ESP)

system to determine the direction of motion and a method is developed to recognize static and persistent gestures.

The motion tracking device is built with BNO055 and Wemos D1 mini, which can obtain the acceleration data of the forearm swing, and use the built-in DTW classifier of the ESP system to predict the motion result. The VR glove is developed by sewing flexible sensors on the fabric glove to read the bending angle of the fingers. The UDP protocol is chosen for data transfer because it is 0.5 seconds faster than the TCP protocol. The obtained forearm swing prediction results and finger bending angles are transmitted to the VE built with the Unity engine using the UDP protocol. The device can provide fifteen static gestures and three continuous gestures. The average successful recognition rate of static gestures is 86.42%, and the average successful recognition rate of continuous gestures is 74.4%. By using the proposed device and gesture recognition method, common gestures can be implemented in VE to enhance the immersive experience.

### **SRQ-2: How to bring daily-life gestures interaction to achieve immersive experience in VW?**

Gestures are humans frequently performed, and manipulated on mobile device in their daily-life. To address this, Chapter 5 focuses on user immersive and intuitive feedback in VR input devices. This chapter develop two applications, a stacking cup game and the conversion of common 2D gestures into VR. Questionnaires are designed and users' EEG signals are analyzed to assess participants' perceptions of the system's usage. Statistical analysis is conducted to evaluate the level of preference and intuition provided by different VR input devices.

The results show that the effectiveness of each device depends on the type of operation of the VR application, and both bare-hand and handheld devices have potential utility in other VR applications. Additionally, the dissertation discusses the use of EEG and VR headsets, where participants were found to be more intuitive and relaxed when using Vive Wands, but Leapmotion has great potential to provide an immersive experience. Overall, the function of realizing daily gestures in VR applications can enhance intuitive interaction and immersive experience especially for pure hand interaction.

### **SRQ-3: How to provide passive haptic feedback for VR?**

The current research suggests that physical devices have limitations when it comes to simulating physical deformation in VR. Chapter 6 of this dissertation details the proposed method for simulating passive haptic feedback.

By using a series of linear equations, we transform the vertex coordinates from virtual objects to simulate their deformation in response to bending, twisting, and pressing. This approach can provide users with a realistic sense of touch and interrelated deformation at a lower development cost compared to previous methods.

The use of physical devices to simulate deformation in VR can be limited. However, the proposed method in Chapter 6 provides a cost-effective solution for simulating passive haptic feedback. By transforming vertex coordinates of virtual objects through linear equations, this approach allows for a realistic sense of touch and deformation in response to bending, twisting, and pressing. This method has the potential to enhance the immersive experience of VR applications and provide users with a more natural interaction with virtual objects.

#### **SRQ-4: How to provide the interaction experience through bidirectional relationships for VR through the concept of double-bridge avatar?**

The existing interactive companion dolls only provide one-way feedback in the PW. In Chapter 7, a solution is proposed to achieve bi-directional feedback between the VW and PW. A motor-driven tail mechanism with three emotional movements is developed, and an extension of the VR application is built depending on the device and VR glove.

This chapter enhance user interaction with virtual content by integrating VR, companion robots, and glove input devices to achieve virtual-real interaction. According to the questionnaire survey results, most users had a positive experience with this interface and believed that a doll that can interact in both virtual and physical worlds can improve their intuitive operation and immersion in the VE. Brainwave analysis showed that users interacting with virtual dolls in a 3D virtual scene had higher theta intensity, indicating a state of focus on the interaction compared to 2D screen interaction. There is no significant difference in alpha strength between 3D VR and 2D screens, suggesting that users were relaxed in either scenario. The research marks the first step towards developing companion robots for virtual-reality interaction. Future work involves making the robot resemble familiar huggable elements and adding more sensors to enhance somatosensory interaction functions.

In summary, the answer of SRQ1 proposes a wearable device and VR glove to provide natural gesture behavior in VR applications. The proposed system can recognize 15 different types of gestures using motion tracking and VR glove technology, enhancing the intuitive interaction experience of

VR applications. SRQ2 focuses on user immersion and intuitive feedback in VR input devices. Chapter 5 develops two applications, a stacking cup game and the conversion of common 2D gestures into VR gestures, and evaluates the effectiveness of different VR input devices using questionnaires and EEG signals. The results suggest that the effectiveness of each device depends on the type of operation of the VR application, and both bare-handed and handheld devices have potential utility in other VR applications. SRQ3 proposes a method for simulating passive haptic feedback in VR applications using linear equations to transform vertex coordinates of virtual objects. This approach provides users with a realistic sense of touch and deformation in response to bending, twisting, and pressing at a lower development cost compared to previous methods. SRQ4 proposes a solution to achieve bi-directional feedback between the virtual and physical world by integrating VR, companion robots, and glove input devices. The dissertation develops a motor-driven tail mechanism with emotional movements and evaluates user experience using questionnaires and brainwave analysis. The results suggest that a doll that can interact in both virtual and physical worlds can improve user intuition and immersion in the VE. Each answer presents a unique contribution to the field of VR interaction and immersion, and the findings can provide guidelines for future research and development in this area.

## NHED Model

**Natural Interaction:** In conclusion, the four studies discussed in this article have made significant contributions to the field of VR interaction and immersion. Natural interaction has been a key focus in these studies, as they aim to enhance the intuitive and immersive experience of VR applications through the use of wearable devices, motion tracking, VR gloves, haptic feedback, and bi-directional feedback. These findings provide important insights and guidelines for future research and development in VR, highlighting the potential of natural interaction to improve user experience and engagement in VE. As VR continues to advance and become more mainstream, natural interaction will undoubtedly play a critical role in shaping the future of this technology.

**Human Factor Feedback:** In conclusion, the four studies presented in this dissertation provide valuable insights into the importance of human factor feedback in the development of VR interaction and immersion technologies. These studies highlight the significance of natural interaction and intuitive feedback in enhancing user experience and engagement in VE. Each study has proposed innovative solutions that utilize motion tracking, VR gloves,

haptic feedback, and bi-directional feedback to create more immersive and intuitive VR applications. By considering the human factor feedback, these studies provide useful guidelines for future research and development in this field. Overall, these findings emphasize the crucial role of human factor feedback in the development of VR technologies that can meet the needs and expectations of users in terms of natural interaction and intuitive feedback.

**Embodiment Sensation:** In conclusion, the studies presented in this article emphasize the importance of embodiment sensation in the development of VR interaction and immersion technologies. The proposed solutions aim to enhance the users' sense of presence and immersion in the virtual environment by providing natural interaction, intuitive feedback, and haptic sensation. The use of VR gloves, wearable devices, and bi-directional feedback mechanisms offers a more embodied experience to users and creates a stronger sense of connection between the physical and virtual worlds. The findings of these studies provide valuable insights into the role of embodiment sensation in improving user experience and engagement in VR applications. The proposed solutions offer useful guidelines for future research and development in this field, emphasizing the need to focus on enhancing embodiment sensation in VR interaction and immersion technologies. Overall, these studies highlight the significance of embodiment sensation in the development of more engaging, immersive, and intuitive VR applications that can provide a more embodied experience to users.

**Double-bridge Avatar:** The four studies presented in this article provide valuable insights into enhancing user experience and immersion in virtual reality applications. One particularly interesting concept proposed in SRQ4 is the integration of VR, companion robots, and hand-worn device to achieve a bi-directional feedback between the virtual and physical world. The development of a motor-driven tail mechanism with emotional movements demonstrates the potential of creating a double-bridge avatar that can interact in both worlds, providing users with a unique and immersive experience. This concept has exciting implications for future research in the field of VR interaction and could lead to the development of even more advanced and immersive VR experiences.

## 8.2 Contribution for Knowledge Science

The main contribution of this research to knowledge science is to provide a technical solution and hardware device based on deepening immersion as a whole. This contribution can provide knowledge science with a solution for human beings through knowledge transformation. In terms of knowledge

enhancement methods and solutions that have been sublimated from a simplex perceptual approach to a cognitive approach. This research includes the following four aspects that contribute to knowledge science: The first contribution to knowledge science, is that the personal knowledge creation models emphasize the individual intuition experience. Bringing human natural behavior by our proposed device into VE is the key to providing the individual intuition experience. The current commercial input device is not suitable for human natural behavior during the VR experience. To address the problem, in Chapter 4 (sections 4.3 and 4.4), a new type of VR glove and motion tracking device have been developed. The second contribution to knowledge science is, the habit of human gestures like experience-based knowledge in our daily lives. Existing gesture recognition usually only recognizes static gestures. Continuous gesture, which is the most commonly performed by humans in physical movements. To address the problem, Chapter 4 (section 4.6) and 5 propose an algorithm to interpret this real-life case in a VE. This is a knowledge synthesis procedure to solve complex real-life problems with this algorithm. As evidenced above, the algorithm proposed in this research can recognize continuous gestures and perform grab, zoom, and rotate gestures as in the real world. The third contribution to knowledge science is that this method can be augmented in the cognition of the object image and the connection between the VE and the PE. According to the existing research results, physical devices cannot fully realize composite simulation from physical deformation to virtual simulation. To address the problem, Chapter 6 proposes a method that can simulate passive haptic feedback by transforming the vertex coordinates through a series of linear equations that are used in virtual scenes to simulate the mesh deformation of virtual objects, and Chapter 7 proposes a new type of interactive companion doll that can provide bidirectional feedback between VW and the real world. Through observation, we found the exiting gap both in integrating the VR input device and interactive device. This enlightens us on how to develop a tool to modify existing reality and provide a new interactive interface for the VR application.

### **8.3 Limitations**

While the work presented in this dissertation has made significant contributions to the development of motion tracking devices, VR gloves, continuous gesture recognition, passive haptic feedback, double-bridge avatars, questionnaire and EEG evaluations for intuitive and immersive experiences in VE, there are still some limitations that need to be acknowledged.



For example, each answer to the SRQ presents a specific solution to a particular problem in VR interaction and immersion. While these solutions can provide valuable insights into designing intuitive and immersive VR interfaces, they cannot be generalized to all VR applications.

To further elaborate on the limitation, while the proposed system in SRQ1 demonstrated the potential of natural gesture behavior in enhancing intuitive interaction in VR applications, it is important to note that the effectiveness of the system may be limited by several factors. For example, the accuracy of the gesture recognition system may be affected by factors such as lighting conditions, device calibration, and user variability in gesture execution. Additionally, while the proposed system provides a range of static and continuous gestures, it may not be able to capture all the nuances of natural hand movements in certain VR applications, which may limit its effectiveness in certain contexts.

Furthermore, while the dissertation in SRQ2 provided insights into the effectiveness of different VR input devices in enhancing user immersion and intuitive feedback, the findings may not be generalizable to all VR applications. The effectiveness of each device may depend on various factors, such as the type of operation required in the VR application and user preferences, and may vary across different contexts.

Similarly, while the approach proposed in SRQ3 for simulating passive haptic feedback in VR applications is cost-effective compared to previous methods, it may not be able to capture all the complexities of haptic feedback in certain contexts. The approach relies on linear equations to transform the vertex coordinates of virtual objects, which may not accurately reflect the physical properties of real-world objects.

Finally, while the dissertation in SRQ4 demonstrated the potential of integrating VR, companion robots, and glove input devices to achieve bi-directional feedback between the virtual and physical worlds, the findings may be limited by the cost and feasibility of implementing such a system in real-world applications. The use of companion robots may also introduce additional ethical considerations, such as privacy concerns and potential negative psychological effects on users.

In summary, the presented solutions is that they focus on specific aspects of VR interaction and immersion, and cannot be regarded as a general answer to the research questions. While the proposed solutions show the potential benefits of using natural gestures and haptic feedback in VR applications, they do not necessarily apply to all types of VR applications or interactions. Additionally, the studies evaluated the effectiveness of the proposed solutions using subjective measures such as questionnaires and EEG signals, which may not fully capture the user experience and may vary depending on individual

preferences and perceptions. Therefore, further research is needed to explore the generalizability of these findings and to develop objective measures to evaluate the effectiveness of different VR input and feedback methods.

## 8.4 Future Work

Based on the limitations identified in this dissertation, future work can be focused on addressing these limitations and exploring the generalizability and effectiveness of the proposed solutions in various VR applications and contexts. Specifically, some potential future directions are:

**Investigating the effectiveness of the proposed solutions in different VR applications and tasks:** Future research can examine the applicability and effectiveness of the proposed solutions in various VR applications, such as gaming, education, and training. It can also investigate how the proposed solutions perform in different tasks, such as manipulation, navigation, and communication.

**Developing objective measures to evaluate the effectiveness of VR input and feedback methods:** Objective measures can provide a more reliable and valid way to evaluate the effectiveness of different VR input and feedback methods. Future research can focus on developing objective measures, such as performance metrics and physiological signals, to evaluate the effectiveness of the proposed solutions.

**Exploring the limitations and potential drawbacks of each approach:** Future research can further investigate the limitations and potential drawbacks of each approach, such as the accuracy and variability of gesture recognition systems, the feasibility and scalability of passive haptic feedback methods, and the ethical considerations of integrating companion robots in VR applications.

**Developing hybrid input and feedback methods:** Hybrid input and feedback methods that combine multiple modalities, such as gesture, haptic, and audio, can potentially enhance the effectiveness and versatility of VR interfaces. Future research can explore the design and evaluation of hybrid input and feedback methods in various VR applications and contexts.

**Investigating the user experience and preferences of different VR input and feedback methods:** User experience and preferences play a critical role in the effectiveness and adoption of VR interfaces. Future research can investigate the user experience and preferences of different VR input and feedback methods, and identify the factors that affect user satisfaction and engagement.

Overall, future work can build on the contributions of this dissertation and advance the understanding and design of intuitive and immersive VR interfaces.

# References

- [1] I. S. MacKenzie, “Human-computer interaction: An empirical research perspective,” 2012.
- [2] M. Schuemie, P. Straaten, M. Krijn, and C. Mast, “Research on presence in virtual reality: A survey,” *Cyberpsychology and behavior : the impact of the Internet, multimedia and virtual reality on behavior and society*, vol. 4, pp. 183–201, 05 2001.
- [3] J. Radianti, T. A. Majchrzak, J. Fromm, and I. Wohlgenannt, “A systematic review of immersive virtual reality applications for higher education: Design elements, lessons learned, and research agenda,” *Computers & Education*, vol. 147, p. 103778, 2020.
- [4] M. Lopez-Garate, A. Lozano-Rodero, and L. Matey, “An adaptive and customizable feedback system for vr-based training simulators,” in *Proceedings of the 7th international joint conference on Autonomous agents and multiagent systems-Volume 3*, 2008, pp. 1635–1638.
- [5] A. Butz, T. Hollerer, S. Feiner, B. MacIntyre, and C. Beshers, “Enveloping users and computers in a collaborative 3d augmented reality,” in *Proceedings 2nd IEEE and ACM International Workshop on Augmented Reality (IWAR’99)*. IEEE, 1999, pp. 35–44.
- [6] C. Kwon, “Verification of the possibility and effectiveness of experiential learning using hmd-based immersive vr technologies,” *Virtual Reality*, vol. 23, no. 1, pp. 101–118, 2019.
- [7] J. Mütterlein and T. Hess, “Immersion, presence, interactivity: Towards a joint understanding of factors influencing virtual reality acceptance and use,” 2017.
- [8] J. Bucher, *Storytelling for virtual reality: methods and principles for crafting immersive narratives*. Routledge, 2017.
- [9] R. A. Bartle, *Designing virtual worlds*. New Riders, 2004.
- [10] R. J. Jacob, A. Girouard, L. M. Hirshfield, M. S. Horn, O. Shaer, E. T. Solovey, and J. Zigelbaum, “Reality-based interaction: A framework

- for post-wimp interfaces,” in *Proceedings of the SIGCHI Conference on Human Factors in Computing Systems*, ser. CHI '08. New York, NY, USA: Association for Computing Machinery, 2008, pp. 201–210. [Online]. Available: <https://doi.org/10.1145/1357054.1357089>
- [11] Y. I. Mari Shirakawa, *Ring Fit Adventure - Nintendo*, 10 2019.
- [12] C. J. Hasser and M. W. Daniels, “Tactile feedback with adaptive controller for a force-reflecting haptic display. 1. design,” in *Proceedings of the 1996 Fifteenth Southern Biomedical Engineering Conference*. IEEE, 1996, pp. 526–529.
- [13] A. Lécuyer, S. Coquillart, A. Kheddar, P. Richard, and P. Coiffet, “Pseudo-haptic feedback: can isometric input devices simulate force feedback?” in *Proceedings IEEE Virtual Reality 2000 (Cat. No. 00CB37048)*. IEEE, 2000, pp. 83–90.
- [14] K. E. MacLean, “Designing with haptic feedback,” in *Proceedings 2000 icra. millennium conference. iee international conference on robotics and automation. symposia proceedings (cat. no. 00ch37065)*, vol. 1. IEEE, 2000, pp. 783–788.
- [15] J. Jerald, *The VR book: Human-centered design for virtual reality*. Morgan & Claypool, 2015.
- [16] E. Chang, H. T. Kim, and B. Yoo, “Virtual reality sickness: a review of causes and measurements,” *International Journal of Human-Computer Interaction*, vol. 36, no. 17, pp. 1658–1682, 2020.
- [17] K. Tanjung, F. Nainggolan, B. Siregar, S. Panjaitan, and F. Fahmi, “The use of virtual reality controllers and comparison between vive, leap motion and senso gloves applied in the anatomy learning system,” in *Journal of Physics: Conference Series*, vol. 1542, no. 1. IOP Publishing, 2020, p. 012026.
- [18] Y.-J. Huang, T. Fujiwara, Y.-X. Lin, W.-C. Lin, and K.-L. Ma, “A gesture system for graph visualization in virtual reality environments,” in *2017 iee pacific visualization symposium (pacificvis)*. IEEE, 2017, pp. 41–45.
- [19] A. Zenner and A. Krüger, “Drag: on: A virtual reality controller providing haptic feedback based on drag and weight shift,” in *Proceedings of the 2019 CHI Conference on Human Factors in Computing Systems*, 2019, pp. 1–12.

- [20] V. Havard, B. Jeanne, M. Lacomblez, and D. Baudry, “Digital twin and virtual reality: a co-simulation environment for design and assessment of industrial workstations,” *Production & Manufacturing Research*, vol. 7, no. 1, pp. 472–489, 2019.
- [21] M. Dianatfar, J. Latokartano, and M. Lanz, “Review on existing vr/ar solutions in human–robot collaboration,” *Procedia CIRP*, vol. 97, pp. 407–411, 2021.
- [22] G. Riva, F. Davide, and W. A. IJsselsteijn, “Being there: The experience of presence in mediated environments,” *Being there: Concepts, effects and measurement of user presence in synthetic environments*, vol. 5, 2003.
- [23] K. M. Stanney, R. R. Mourant, and R. S. Kennedy, “Human factors issues in virtual environments: A review of the literature,” *Presence*, vol. 7, no. 4, pp. 327–351, 1998.
- [24] G. Riva, “From virtual to real body: virtual reality as embodied technology,” *J. Cyber Ther. Rehabil*, vol. 1, pp. 7–22, 2008.
- [25] L. L. Bozgeyikli, “Give me a hand: Exploring bidirectional mutual embodied tangible interaction in virtual reality,” in *2021 IEEE International Conference on Consumer Electronics (ICCE)*. IEEE, 2021, pp. 1–6.
- [26] Y. Nakamori, *Knowledge science: Modeling the knowledge creation process*. CRC Press, 2011.
- [27] I. Sutherland, “Head mounted three dimensional display,” in *Thompson Books*. Washington, D.C.: Proceedings of the AFIPS Fakk Joint Computer Conference, 1968, pp. 757–764.
- [28] D. Ungureanu, F. Bogo, S. Galliani, P. Sama, X. Duan, C. Meekhof, J. Stühmer, T. J. Cashman, B. Tekin, J. L. Schönberger, P. Olszta, and M. Pollefeys, “Hololens 2 research mode as a tool for computer vision research,” 2020. [Online]. Available: <https://arxiv.org/abs/2008.11239>
- [29] R. Tredinnick, B. Boettcher, S. Smith, S. Solovy, and K. Ponto, “Unicave: A unity3d plugin for non-head mounted vr display systems,” in *2017 IEEE Virtual Reality (VR)*, 2017, pp. 393–394.
- [30] A. de Giorgio, M. Romero, M. Onori, and L. Wang, “Human-machine collaboration in virtual reality for adaptive production engineering,” vol. 11, 09 2017, pp. 1279–1287.

- [31] Z. Zhang, “Microsoft kinect sensor and its effect,” *IEEE MultiMedia*, vol. 19, no. 2, pp. 4–10, 2012.
- [32] C. Xi, J. Chen, C. Zhao, Q. Pei, and L. Liu, “Real-time hand tracking using kinect,” in *Proceedings of the 2nd International Conference on Digital Signal Processing*, 2018, pp. 37–42.
- [33] K. Vasylevska, I. Podkosova, and H. Kaufmann, “Teaching virtual reality with htc vive and leap motion,” in *SIGGRAPH Asia 2017 Symposium on Education*, ser. SA ’17. New York, NY, USA: Association for Computing Machinery, 2017. [Online]. Available: <https://doi.org/10.1145/3134368.3139221>
- [34] L. Keselman, J. I. Woodfill, A. Grunnet-Jepsen, and A. Bhowmik, “Intel realsense stereoscopic depth cameras,” 2017. [Online]. Available: <https://arxiv.org/abs/1705.05548>
- [35] A. HENSON, “Wake : Exploring co-located co-presence in virtual reality,” 2019.
- [36] Y. Wu and L. Pei, “Gyroscope calibration via magnetometer,” *IEEE Sensors Journal*, vol. PP, pp. 1–1, 06 2017.
- [37] K. Zhu and L. Shi, “Motion control in vr — real-time upper limb tracking via imu and flex sensor,” 2016.
- [38] D. Roetenberg, H. Luinge, and P. Slycke, “Xsens mvn: Full 6dof human motion tracking using miniature inertial sensors,” *Xsens Motion Technol. BV Tech. Rep.*, vol. 3, 01 2009.
- [39] A. Kratky, “Transparent touch - interacting with a multi-layered touch-sensitive display system,” 08 2015.
- [40] M. Borges, A. Symington, B. Coltin, T. Smith, and R. Ventura, “Htc vive: Analysis and accuracy improvement,” in *2018 IEEE/RSJ International Conference on Intelligent Robots and Systems (IROS)*, 2018, pp. 2610–2615.
- [41] Sony, “Playstation joystick,” 2022.
- [42] G. W. YOUNG, A. KEHOE, and D. MURPHY, “ usability testing of video game controllers: A case study,” in *Games User Research*. AK Peters/CRC Press, 2017, pp. 163–206.

- [43] E. Bozgeyikli, A. Raij, S. Katkooi, and R. Dubey, “Point and teleport locomotion technique for virtual reality,” in *Proceedings of the 2016 Annual Symposium on Computer-Human Interaction in Play*, ser. CHI PLAY ’16. New York, NY, USA: Association for Computing Machinery, 2016, pp. 205–216. [Online]. Available: <https://doi.org/10.1145/2967934.2968105>
- [44] N. Coomer, S. Bullard, W. Clinton, and B. Williams-Sanders, “Evaluating the effects of four vr locomotion methods: Joystick, arm-cycling, point-tugging, and teleporting,” in *Proceedings of the 15th ACM Symposium on Applied Perception*, ser. SAP ’18. New York, NY, USA: Association for Computing Machinery, 2018. [Online]. Available: <https://doi.org/10.1145/3225153.3225175>
- [45] R. A. Beti, F. Al-Khatib, and D. M. Cook, “The efficacy of using virtual reality for job interviews and its effects on mitigating discrimination,” in *Recent Advances in Information and Communication Technology 2018: Proceedings of the 14th International Conference on Computing and Information Technology (IC2IT 2018)*. Springer, 2019, pp. 43–52.
- [46] M. E. Benalcázar, C. Motoche, J. A. Zea, A. G. Jaramillo, C. E. Anchundia, P. Zambrano, M. Segura, F. Benalcázar Palacios, and M. Pérez, “Real-time hand gesture recognition using the myo armband and muscle activity detection,” in *2017 IEEE Second Ecuador Technical Chapters Meeting (ETCM)*, 2017, pp. 1–6.
- [47] B. Chakraborty, D. Sarma, M. Bhuyan, and K. MacDorman, “A review of constraints on vision-based gesture recognition for human-computer interaction,” *IET Computer Vision*, vol. 12, 11 2017.
- [48] D. Bowman, C. Wingrave, J. Campbell, and V. Ly, “Using pinch gloves for both natural and abstract interaction techniques in virtual environments,” *Proceedings of HCI International*, 01 2001.
- [49] S. Burbach, A. Steiger, and C. Giesser, “Suitability testing of the lucidgloves prototype 4 for extended reality medical teaching,” *Current Directions in Biomedical Engineering*, vol. 8, pp. 419–422, 08 2022.
- [50] J. Piskozub and P. Strumillo, “Reducing the number of sensors in the data glove for recognition of static hand gestures,” *Applied Sciences*, vol. 12, p. 7388, 07 2022.

- [51] B. O’Flynn, J. Torres Sanchez, S. Tedesco, B. Downes, J. Connolly, J. Condell, and K. Curran, “Novel smart glove technology as a biomechanical monitoring tool,” *Sensors and Transducers*, vol. 193, pp. 23–32, 10 2015.
- [52] S. Brandenburg and K. Sachse, “Intuition comes with experience,” in *Human factors: A view from an integrative perspective. Proceedings of the Human Factors and Ergonomics Society of Europe Conference*, 2012, pp. 213–223.
- [53] A. Blackler, V. Popovic, and D. Mahar, “Empirical investigations into intuitive interaction: A summary,” *MMIInteraktiv*, vol. 13, 01 2007.
- [54] —, “Concepts of intuitive interaction,” in *Workshop Proceedings der Tgung Mensch & Computer 2009*, H. Wandke, Ed. Germany: Logos Verlag Berlin, 2009, pp. 76–79. [Online]. Available: <https://eprints.qut.edu.au/31031/>
- [55] D. Michael-Grigoriou, P. Yiannakou, and M. Christofi, “Intuitive interaction for exploring human anatomy in a vr setup,” 10 2017, pp. 1–4.
- [56] S. Desai, A. Blackler, and V. Popovic, “Intuitive interaction in a mixed reality system,” 06 2016.
- [57] M. J. Schuemie and C. A. van der Mast, “Presence: Interacting in vr?”
- [58] S. B, I. Ladeira, C. Winterbottom, and E. Blake, “An investigation on the effects of mediation in a storytelling virtual environment,” vol. 2897, 11 2002.
- [59] D. Nunez and E. Blake, “Cognitive presence as a unified concept of virtual reality effectiveness,” in *Proceedings of the 1st International Conference on Computer Graphics, Virtual Reality and Visualisation*, ser. AFRIGRAPH ’01. New York, NY, USA: Association for Computing Machinery, 2001, pp. 115–118. [Online]. Available: <https://doi.org/10.1145/513867.513892>
- [60] C. Jicol, C. H. Wan, B. Doling, C. H. Illingworth, J. Yoon, C. Headey, C. Lutteroth, M. J. Proulx, K. Petrini, and E. O’Neill, “Effects of emotion and agency on presence in virtual reality,” in *Proceedings of the 2021 CHI Conference on Human Factors in Computing Systems*, ser. CHI ’21. New York, NY, USA: Association for Computing Machinery, 2021. [Online]. Available: <https://doi.org/10.1145/3411764.3445588>



- [61] J.-P. Tauscher, F. W. Schottky, S. Grogorick, P. M. Bittner, M. Mustafa, and M. Magnor, “Immersive eeg: Evaluating electroencephalography in virtual reality,” in *2019 IEEE Conference on Virtual Reality and 3D User Interfaces (VR)*, 2019, pp. 1794–1800.
- [62] C. Tremmel, C. Herff, T. Sato, K. Rechowicz, Y. Yamani, and D. Krusienski, “Estimating cognitive workload in an interactive virtual reality environment using eeg,” *Frontiers in Human Neuroscience*, vol. 13, p. 401, 11 2019.
- [63] “Neurosky.” [Online]. Available: <https://en.wikipedia.org/wiki/NeuroSky>
- [64] C. Sá, P. V. Gomes, A. Marques, and A. Correia, “The use of portable eeg devices in development of immersive virtual reality environments for converting emotional states into specific commands,” *Proceedings*, vol. 54, no. 1, 2020. [Online]. Available: <https://www.mdpi.com/2504-3900/54/1/43>
- [65] “Emotiv epoc+.” [Online]. Available: <https://www.emotiv.com/epoc/>
- [66] A. K. Singh, H.-T. Chen, Y.-F. Cheng, J.-T. King, L.-W. Ko, K. Gramann, and C.-T. Lin, “Visual appearance modulates prediction error in virtual reality,” *IEEE Access*, vol. 6, pp. 24 617–24 624, 2018.
- [67] J. Rzepecki, J. Delcourt, M. Perreira Da Silva, and P. Le Callet, “Virtual interactions: Can eeg help make the difference with real interaction?” 07 2012, pp. 151–156.
- [68] L. Aftanas and S. Golocheikine, “Human anterior and frontal midline theta and lower alpha reflect emotionally positive state and internalized attention: High-resolution eeg investigation of meditation,” *Neuroscience letters*, vol. 310, pp. 57–60, 10 2001.
- [69] S. Hertweck, D. Weber, H. Alwanni, F. Unruh, M. Fischbach, M. E. Latoschik, and T. Ball, “Brain activity in virtual reality: Assessing signal quality of high-resolution eeg while using head-mounted displays,” in *2019 IEEE Conference on Virtual Reality and 3D User Interfaces (VR)*, 2019, pp. 970–971.
- [70] E. R. Kannegieser and J. Ratz, “J.: Measuring game immersion and flow with electroencephalography,” in *14th International Conference on Game and Entertainment Technologies (GET 2021)*, 2021, p. 124.

- [71] A. Zenner, F. Kosmalla, J. Ehrlich, P. Hell, G. Kahl, C. Murlowski, M. Speicher, F. Daiber, D. Heinrich, and A. Krüger, “A virtual reality couch configurator leveraging passive haptic feedback,” in *Extended Abstracts of the 2020 CHI Conference on Human Factors in Computing Systems*, 2020, pp. 1–8.
- [72] M. Meehan, B. Insko, M. Whitton, and F. P. Brooks Jr, “Physiological measures of presence in stressful virtual environments,” *Acm transactions on graphics (tog)*, vol. 21, no. 3, pp. 645–652, 2002.
- [73] M. Meehan, B. Insko, M. Whitton, and F. P. Brooks, “Physiological measures of presence in stressful virtual environments,” *ACM Trans. Graph.*, vol. 21, no. 3, pp. 645–652, jul 2002. [Online]. Available: <https://doi.org/10.1145/566654.566630>
- [74] A. El Saddik, “Digital twins: The convergence of multimedia technologies,” *IEEE MultiMedia*, vol. 25, no. 2, pp. 87–92, 2018.
- [75] I. Essa, “Ubiquitous sensing for smart and aware environments,” *IEEE Personal Communications*, vol. 7, no. 5, pp. 47–49, 2000.
- [76] F. Paulovich, M. C. Oliveira, and O. Oliveira, “A future with ubiquitous sensing and intelligent systems,” *ACS Sensors*, vol. 3, 07 2018.
- [77] A. Abou Allaban, M. Wang, and T. Padir, “A systematic review of robotics research in support of in-home care for older adults.” in *Information*, 2020, p. 11(2):75.
- [78] G. Milliez, “Buddy: A companion robot for the whole family,” in *Companion of the 2018 ACM/IEEE International Conference on Human-Robot Interaction*, ser. HRI ’18. New York, NY, USA: Association for Computing Machinery, 2018, p. 40. [Online]. Available: <https://doi.org/10.1145/3173386.3177839>
- [79] H. L. Bradwell, K. J. Edwards, R. Winnington, S. Thill, and R. B. Jones, “Companion robots for older people: importance of user-centred design demonstrated through observations and focus groups comparing preferences of older people and roboticists in south west england,” *BMJ Open*, vol. 9, no. 9, 2019. [Online]. Available: <https://bmjopen.bmj.com/content/9/9/e032468>
- [80] M. W, C. M, B. E, J. C, K. B, C. G, and G. C., “Exploring the effect of companion robots on emotional expression in older adults with

- dementia: a pilot randomized controlled trial,” *J Gerontol Nurs.*, pp. 39(5):46–53., 2013.
- [81] G. Lane, D. Noronha, A. Rivera, K. Craig, C. Yee, B. Mills, and E. Villanueva, “Effectiveness of a social robot, ”paro,” in a va long-term care setting,” *Psychological Services*, vol. 13, 05 2016.
- [82] A. Kotov, N. Arinkin, L. Zaidelman, and A. Zinina, “Speech understanding system for emotional companion robots,” *Procedia Computer Science*, vol. 169, pp. 63–69, 01 2020.
- [83] E. Hirokawa and K. Suzuki, “Design of a huggable social robot with affective expressions using projected images,” *Applied Sciences*, vol. 8, p. 2298, 11 2018.
- [84] K. Baraka, P. Alves-Oliveira, and T. Ribeiro, “An extended framework for characterizing social robots,” 2019. [Online]. Available: <https://arxiv.org/abs/1907.09873>
- [85] J. Złotowski, H. Sumioka, S. Nishio, D. Glas, C. Bartneck, and H. Ishiguro, “Appearance of a robot affects the impact of its behaviour on perceived trustworthiness and empathy,” *Paladyn, Journal of Behavioral Robotics*, vol. 7, 01 2016.
- [86] S. Kwak, “The impact of the robot appearance types on social interaction with a robot and service evaluation of a robot,” *Archives of Design Research*, 05 2014.
- [87] Y. Fernaeus, M. Hakansson, M. Jacobsson, and S. Ljungblad, “How do you play with a robotic toy animal? a long-term study of pleo,” in *Proceedings of the 9th International Conference on Interaction Design and Children*, ser. IDC ’10. New York, NY, USA: Association for Computing Machinery, 2010, pp. 39–48. [Online]. Available: <https://doi.org/10.1145/1810543.1810549>
- [88] S. Parekh and J. C. Lim, “Receptivity & interaction of social robots in hospitals,” in *Companion of the 2020 ACM/IEEE International Conference on Human-Robot Interaction*, ser. HRI ’20. New York, NY, USA: Association for Computing Machinery, 2020, pp. 389–391. [Online]. Available: <https://doi.org/10.1145/3371382.3378243>
- [89] S. Jeong, C. Breazeal, D. Logan, and P. Weinstock, “Huggable: The impact of embodiment on promoting socio-emotional interactions

- for young pediatric inpatients,” in *Proceedings of the 2018 CHI Conference on Human Factors in Computing Systems*, ser. CHI '18. New York, NY, USA: Association for Computing Machinery, 2018, pp. 1–13. [Online]. Available: <https://doi.org/10.1145/3173574.3174069>
- [90] “Reeman robot.” [Online]. Available: <https://www.reemanrobot.com/delivery-robot/food-delivery-robot/autonomous-delivery-robot.html>
- [91] S. Feng, E. Whitman, X. Xinjilefu, and C. G. Atkeson, “Optimization based full body control for the atlas robot,” in *2014 IEEE-RAS International Conference on Humanoid Robots*, 2014, pp. 120–127.
- [92] S. Han, B. Liu, R. Cabezas, C. D. Twigg, P. Zhang, J. Petkau, T.-H. Yu, C.-J. Tai, M. Akbay, Z. Wang *et al.*, “Megatrack: monochrome egocentric articulated hand-tracking for virtual reality,” *ACM Transactions on Graphics (ToG)*, vol. 39, no. 4, pp. 87–1, 2020.
- [93] R. Takada, J. Kadomoto, and B. Shizuki, “A sensing technique for data glove using conductive fiber,” in *Extended Abstracts of the 2019 CHI Conference on Human Factors in Computing Systems*, ser. CHI EA '19. New York, NY, USA: Association for Computing Machinery, 2019, pp. 1–4. [Online]. Available: <https://doi.org/10.1145/3290607.3313260>
- [94] H. Kato, M. Billingham, I. Poupyrev, K. Imamoto, and K. Tachibana, “Virtual object manipulation on a table-top ar environment,” in *Proceedings IEEE and ACM International Symposium on Augmented Reality (ISAR 2000)*. Ieee, 2000, pp. 111–119.
- [95] K. Chu, W. Lu, K. Oka, K. Takashima, and Y. Kitamura, “A study on ar authoring using mobile devices for educators.” in *ICAT-EGVE*, 2018, pp. 175–182.
- [96] R. F. Pinto, C. D. Borges, A. M. Almeida, and I. C. Paula, “Static hand gesture recognition based on convolutional neural networks,” *Journal of Electrical and Computer Engineering*, vol. 2019, pp. 1–12, 2019.
- [97] D. Chakraborty, D. Garg, A. Ghosh, and J. H. Chan, “Trigger detection system for american sign language using deep convolutional neural networks,” in *Proceedings of the 10th International Conference on Advances in Information Technology*, 2018, pp. 1–6.
- [98] M. Z. Islam, M. S. Hossain, R. ul Islam, and K. Andersson, “Static hand gesture recognition using convolutional neural network with data augmentation,” in *2019 Joint 8th International Conference on Informatics*,

*Electronics & Vision (ICIEV) and 2019 3rd International Conference on Imaging, Vision & Pattern Recognition (icIVPR)*. IEEE, 2019, pp. 324–329.

- [99] A. Fischer and J. M. Vance, “Phantom haptic device implemented in a projection screen virtual environment,” in *Proceedings of the workshop on Virtual environments 2003*, 2003, pp. 225–229.
- [100] H. Benko, C. Holz, M. Sinclair, and E. Ofek, “Normaltouch and texturetouch: High-fidelity 3d haptic shape rendering on handheld virtual reality controllers,” in *Proceedings of the 29th annual symposium on user interface software and technology*, 2016, pp. 717–728.
- [101] M. Sinclair, E. Ofek, M. Gonzalez-Franco, and C. Holz, “Capstan-crunch: A haptic vr controller with user-supplied force feedback,” in *Proceedings of the 32nd annual ACM symposium on user interface software and technology*, 2019, pp. 815–829.
- [102] J. C. McClelland, R. J. Teather, and A. Girouard, “Haptobend: shape-changing passive haptic feedback in virtual reality,” in *Proceedings of the 5th Symposium on Spatial User Interaction*, 2017, pp. 82–90.
- [103] M. Azmandian, M. Hancock, H. Benko, E. Ofek, and A. D. Wilson, “Haptic retargeting: Dynamic repurposing of passive haptics for enhanced virtual reality experiences,” in *Proceedings of the 2016 chi conference on human factors in computing systems*, 2016, pp. 1968–1979.
- [104] H.-Y. Lee, R.-J. Cherng, and C.-H. Lin, “Development of a virtual reality environment for somatosensory and perceptual stimulation in the balance assessment of children,” *Computers in biology and medicine*, vol. 34, no. 8, pp. 719–733, 2004.
- [105] E. Fujinawa, S. Yoshida, Y. Koyama, T. Narumi, T. Tanikawa, and M. Hirose, “Computational design of hand-held vr controllers using haptic shape illusion,” *Proceedings of the 23rd ACM Symposium on Virtual Reality Software and Technology*, 2017.
- [106] G. Batchuluun, R. A. Naqvi, W. Kim, and K. R. Park, “Body-movement-based human identification using convolutional neural network,” *Expert Syst. Appl.*, vol. 101, no. C, pp. 56–77, jul 2018. [Online]. Available: <https://doi.org/10.1016/j.eswa.2018.02.016>

- [107] M. Slater and M. V. Sanchez-Vives, “Enhancing our lives with immersive virtual reality,” *Frontiers in Robotics and AI*, vol. 3, 2016. [Online]. Available: <https://www.frontiersin.org/articles/10.3389/frobt.2016.00074>
- [108] R. P. McMahan and N. S. Herrera, “Affect: Altered-fidelity framework for enhancing cognition and training,” *Frontiers in ICT*, vol. 3, 2016. [Online]. Available: <https://www.frontiersin.org/articles/10.3389/fict.2016.00029>
- [109] D. Shafer, “The effects of interaction fidelity on game experience in virtual reality (accepted for forthcoming publication in psychology of popular media),” 02 2021.
- [110] A. Ometov, V. Shubina, L. Klus, J. Skibińska, S. Saafi, P. Pascacio, L. Flueratoru, D. Q. Gaibor, N. Chukhno, O. Chukhno, A. Ali, A. Channa, E. Svertoka, W. B. Qaim, R. Casanova-Marqués, S. Holcer, J. Torres-Sospedra, S. Casteleyn, G. Ruggeri, G. Araniti, R. Burget, J. Hosek, and E. S. Lohan, “A survey on wearable technology: History, state-of-the-art and current challenges,” *Computer Networks*, vol. 193, p. 108074, 2021. [Online]. Available: <https://www.sciencedirect.com/science/article/pii/S1389128621001651>
- [111] “Intel edison.” [Online]. Available: [https://www.intel.com/content/dam/support/us/en/documents/edison/sb/edison\\_pb\\_331179002.pdf](https://www.intel.com/content/dam/support/us/en/documents/edison/sb/edison_pb_331179002.pdf)
- [112] “Nodemcu.” [Online]. Available: [https://www.espressif.com/sites/default/files/documentation/0a-esp8266ex\\_datasheet\\_en.pdf](https://www.espressif.com/sites/default/files/documentation/0a-esp8266ex_datasheet_en.pdf)
- [113] “Bno055.” [Online]. Available: <https://www.bosch-sensortec.com/products/smart-sensors/bno055/>
- [114] J. Perret and E. Vander Poorten, “Touching virtual reality: A review of haptic gloves,” in *ACTUATOR 2018; 16th International Conference on New Actuators*, 2018, pp. 1–5.
- [115] S. Shin, H. U. Yoon, and B. Yoo, “Hand gesture recognition using egain-silicone soft sensors,” *Sensors*, vol. 21, no. 9, 2021. [Online]. Available: <https://www.mdpi.com/1424-8220/21/9/3204>
- [116] “Manusglove.” [Online]. Available: <https://www.manus-meta.com/>
- [117] C. Tzafestas and P. Coiffet, “Computing optimal forces for generalised kinesthetic feedback on the human hand during virtual grasping and manipulation,” 05 1997, pp. 118 – 123 vol.1.

- [118] F. Xia, L. T. Yang, L. Wang, and A. Vinel, "Internet of things," *International journal of communication systems*, vol. 25, no. 9, p. 1101, 2012.
- [119] J. Foottit, D. Brown, S. Marks, and A. M. Connor, "Development of a wearable haptic game interface," *EAI Endorsed Trans. Creative Technol.*, vol. 3, p. e5, 2016.
- [120] ———, "An intuitive tangible game controller," in *Proceedings of the 2014 Conference on Interactive Entertainment*, ser. IE2014. New York, NY, USA: Association for Computing Machinery, 2014, pp. 1–7. [Online]. Available: <https://doi.org/10.1145/2677758.2677774>
- [121] S. Patil and S. Patil, "A real time sensor data monitoring system for wireless sensor network," 12 2015, pp. 525–528.
- [122] Y. LI, J. HUANG, F. TIAN, H.-A. WANG, and G.-Z. DAI, "Gesture interaction in virtual reality," *Virtual Reality & Intelligent Hardware*, vol. 1, no. 1, pp. 84–112, 2019. [Online]. Available: <https://www.sciencedirect.com/science/article/pii/S2096579619300075>
- [123] J. Xu, P. Gannon, K. Emmorey, J. Smith, and A. Braun, "Symbolic gestures and spoken language are processed by a common neural system," *Proceedings of the National Academy of Sciences of the United States of America*, vol. 106, pp. 20 664–9, 11 2009.
- [124] C. Hummels and P. J. Stappers, "Meaningful gestures for human computer interaction: Beyond hand postures," 05 1998, pp. 591 – 596.
- [125] M. W. Alibali and S. Kita, "Gesture highlights perceptually present information for speakers," *Gesture*, vol. 10, no. 1, pp. 3–28, 2010.
- [126] E. De Stefani and D. De Marco, "Language, gesture, and emotional communication: An embodied view of social interaction," *Frontiers in Psychology*, vol. 10, 2019. [Online]. Available: <https://www.frontiersin.org/articles/10.3389/fpsyg.2019.02063>
- [127] J. Weissmann and R. Salomon, "Gesture recognition for virtual reality applications using data gloves and neural networks," in *IJCNN'99. International Joint Conference on Neural Networks. Proceedings (Cat. No.99CH36339)*, vol. 3, 1999, pp. 2043–2046 vol.3.
- [128] H. Sekar, R. Rajashekar, G. Srinivasan, P. Suresh, and V. Vijayaraghavan, "Low-cost intelligent static gesture recognition system," in *2016 Annual IEEE Systems Conference (SysCon)*, 2016, pp. 1–6.

- [129] D. A. Mellis, B. Zhang, A. Leung, and B. Hartmann, “Machine learning for makers: Interactive sensor data classification based on augmented code examples,” in *Proceedings of the 2017 Conference on Designing Interactive Systems*, ser. DIS ’17. New York, NY, USA: Association for Computing Machinery, 2017, pp. 1213–1225. [Online]. Available: <https://doi.org/10.1145/3064663.3064735>
- [130] N. Gillian and J. A. Paradiso, “The gesture recognition toolkit,” *Journal of Machine Learning Research*, vol. 15, no. 101, pp. 3483–3487, 2014. [Online]. Available: <http://jmlr.org/papers/v15/gillian14a.html>
- [131] L. Machado and J. L. Bernardes, “A practical evaluation of the influence of input devices on playability,” in *International Conference on Human-Computer Interaction*. Springer, 2016, pp. 385–395.
- [132] L. J. Tun, R. J. Rajapakse, and K. Miyata, “Haptwarp: Implementation of bend, twist, and press manipulations for intuitive interaction in between the virtual and physical world,” *Journal of Robotics, Networking and Artificial Life*, 2022.
- [133] W. Sun, M. Huang, R. Yang, J. Han, and Y. Yue, “Mental workload evaluation of virtual object manipulation on webvr: An eeg study,” in *2021 14th International Conference on Human System Interaction (HSI)*, 2021, pp. 1–6.
- [134] R. Moseley, “Immersive brain entrainment in virtual worlds: actualizing meditative states,” in *Emerging Trends and Advanced Technologies for Computational Intelligence: Extended and Selected Results from the Science and Information Conference 2015*. Springer, 2016, pp. 315–346.
- [135] L. George and A. Lécuyer, “An overview of research on” passive” brain-computer interfaces for implicit human-computer interaction,” in *International Conference on Applied Bionics and Biomechanics ICABB 2010-Workshop W1” Brain-Computer Interfacing and Virtual Reality*, 2010.
- [136] X. Zhou, Y. Jin, L. Jia, and C. Xue, “Study on hand–eye cordination area with bare-hand click interaction in virtual reality,” *Applied Sciences*, vol. 11, no. 13, p. 6146, 2021.
- [137] S. Rutkowski, M. Adamczyk, A. Pastuła, E. Gos, C. Luque-Moreno, and A. Rutkowska, “Training using a commercial immersive virtual



- reality system on hand–eye coordination and reaction time in young musicians: A pilot study,” *International journal of environmental research and public health*, vol. 18, no. 3, p. 1297, 2021.
- [138] “ads1115.” [Online]. Available: <https://www.ti.com/lit/ds/symlink/ads1115.pdf>
- [139] A. Blackler, V. Popovic, and D. Mahar, “Investigating users’ intuitive interaction with complex artefacts,” *Applied Ergonomics*, vol. 41, pp. 72–92, 01 2010.
- [140] S. Diefenbach and D. Ullrich, “An experience perspective on intuitive interaction: Central components and the special effect of domain transfer distance,” *Interacting with Computers*, vol. 27, 04 2015.
- [141] T. Iwaki and M. Noshiro, “Eeg activity over frontal regions during positive and negative emotional experience,” in *2012 ICME International Conference on Complex Medical Engineering (CME)*, 2012, pp. 418–422.
- [142] T. Y. Wen and S. A. Mohd Aris, “Hybrid approach of eeg stress level classification using k-means clustering and support vector machine,” *IEEE Access*, vol. 10, pp. 18 370–18 379, 2022.
- [143] J. Nam, H. Y. Chung, Y. ah Seong, and H. Lee, “A new terrain in hci: Emotion recognition interface using biometric data for an immersive vr experience,” *ArXiv*, vol. abs/1912.01177, 2019.
- [144] J. Vidal, “Real-time detection of brain events in eeg,” *Proceedings of the IEEE*, vol. 65, no. 5, pp. 633–641, 1977.
- [145] A. X. Patel and E. T. Bullmore, “A wavelet-based estimator of the degrees of freedom in denoised fmri time series for probabilistic testing of functional connectivity and brain graphs,” *NeuroImage*, vol. 142, pp. 14–26, 2016.
- [146] “Looxid link unity sdk.” [Online]. Available: <https://looxidlabs.github.io/link-sdk/>
- [147] A. Dan and M. Reiner, “Eeg-based cognitive load of processing events in 3d virtual worlds is lower than processing events in 2d displays,” *International Journal of Psychophysiology*, vol. 122, pp. 75–84, 2017.

- [148] D. White, J. Ciorciari, C. Carbis, and D. Liley, “Eeg correlates of virtual reality hypnosis,” *International Journal of Clinical and Experimental Hypnosis*, vol. 57, no. 1, pp. 94–116, 2008.
- [149] E. Magosso, F. De Crescenzo, G. Ricci, S. Piastra, and M. Ursino, “Eeg alpha power is modulated by attentional changes during cognitive tasks and virtual reality immersion,” *Computational intelligence and neuroscience*, vol. 2019, 2019.
- [150] W. B. Ng, A. Saidatul, Y. Chong, and Z. Ibrahim, “Psd-based features extraction for eeg signal during typing task,” in *IOP Conference Series: Materials Science and Engineering*, vol. 557, no. 1. IOP Publishing, 2019, p. 012032.
- [151] H. J. Kang, J.-h. Shin, and K. Ponto, “A comparative analysis of 3d user interaction: How to move virtual objects in mixed reality,” in *2020 IEEE Conference on Virtual Reality and 3D User Interfaces (VR)*, 2020, pp. 275–284.
- [152] E. Strasnick, C. Holz, E. Ofek, M. Sinclair, and H. Benko, *Haptic Links: Bimanual Haptics for Virtual Reality Using Variable Stiffness Actuation*. New York, NY, USA: Association for Computing Machinery, 2018, pp. 1–12. [Online]. Available: <https://doi.org/10.1145/3173574.3174218>
- [153] N. Ryu, W. Lee, M. J. Kim, and A. Bianchi, *ElaStick: A Handheld Variable Stiffness Display for Rendering Dynamic Haptic Response of Flexible Object*. New York, NY, USA: Association for Computing Machinery, 2020, pp. 1035–1045. [Online]. Available: <https://doi.org/10.1145/3379337.3415862>
- [154] Y. Tokuyama, R. J. Rajapakse, Y. Nakazawa, and K. Konno, “Torque display method for free-form deformation with haptic device,” in *2009 ICCAS-SICE*, 2009, pp. 3803–3808.
- [155] I. Choi, E. Ofek, H. Benko, M. Sinclair, and C. Holz, *CLAW: A Multifunctional Handheld Haptic Controller for Grasping, Touching, and Triggering in Virtual Reality*. New York, NY, USA: Association for Computing Machinery, 2018, pp. 1–13. [Online]. Available: <https://doi.org/10.1145/3173574.3174228>
- [156] A. TAKAHASHI, K. TANABE, and H. KAJIMOTO, *Haptic interface using tendon electrical stimulation with consideration of multimodal*

- presentation*, 2019, vol. 1, no. 2, pp. 163–175. [Online]. Available: <https://www.sciencedirect.com/science/article/pii/S2096579619300142>
- [157] K. Song, S. Kim, S. Jin, S. Kim, S. Lee, J.-S. Kim, J.-M. Park, and Y. Cha, *Pneumatic actuator and flexible piezoelectric sensor for soft virtual reality glove system*, 07 2019, vol. 9.
- [158] E. J. Gonzalez and S. Follmer, “Investigating the detection of bimanual haptic retargeting in virtual reality,” in *25th ACM Symposium on Virtual Reality Software and Technology*, ser. VRST ’19. New York, NY, USA: Association for Computing Machinery, 2019. [Online]. Available: <https://doi.org/10.1145/3359996.3364248>
- [159] N. Ryu, H.-Y. Jo, M. Pahud, M. Sinclair, and A. Bianchi, *GamesBond: Bimanual Haptic Illusion of Physically Connected Objects for Immersive VR Using Grip Deformation*. New York, NY, USA: Association for Computing Machinery, 2021. [Online]. Available: <https://doi.org/10.1145/3411764.3445727>
- [160] T.-Y. Wei, H.-R. Tsai, Y.-S. Liao, C. Tsai, Y.-S. Chen, C. Wang, and B.-Y. Chen, *ElastiLinks: Force Feedback between VR Controllers with Dynamic Points of Application of Force*. New York, NY, USA: Association for Computing Machinery, 2020, pp. 1023–1034. [Online]. Available: <https://doi.org/10.1145/3379337.3415836>
- [161] Y. Guiard, *Asymmetric Division of Labor in Human Skilled Bimanual Action*, 08 2013, vol. 19, pp. 486–517.
- [162] M. Fairhurst, E. Travers, V. Hayward, and O. Deroy, *Confidence is higher in touch than in vision in cases of perceptual ambiguity*, 10 2018.
- [163] J.-C. Léon, J.-P. Pernot, S. Guillet, F. Giannini, and B. Falcidieno, “Aesthetic design of shapes using fully free form deformation features,” 01 2005.
- [164] R. J. Rajapakse, “The influence of texture on perceiving haptic stiffness,” *Kansei Engineering International Journal*, vol. 11, 10 2012.
- [165] M. Maroto-Gómez, Á. Castro-González, J. C. Castillo, M. Malfaz, and M. A. Salichs, “A bio-inspired motivational decision making system for social robots based on the perception of the user,” *Sensors*, vol. 18, no. 8, p. 2691, 2018.

- [166] C. Breazeal, “Social robots for health applications,” in *2011 Annual international conference of the IEEE engineering in medicine and biology society*. IEEE, 2011, pp. 5368–5371.
- [167] J. Busby Grant and D. Herath, “Social robots: Principles of interaction design and user studies,” in *Foundations of Robotics*. Springer, 2022, pp. 377–413.
- [168] A. A. Scoglio, E. D. Reilly, J. A. Gorman, and C. E. Drebing, “Use of social robots in mental health and well-being research: systematic review,” *Journal of medical Internet research*, vol. 21, no. 7, p. e13322, 2019.
- [169] R. P. Sharma and G. K. Verma, “Human computer interaction using hand gesture,” *Procedia Computer Science*, vol. 54, pp. 721–727, 2015.
- [170] J. Woo, Y. Ohshima, and N. Kubota, “Robot partner development platform for human-robot interaction based on a user-centered design approach,” *Applied Sciences*, vol. 10, no. 22, p. 7992, 2020.
- [171] E. Nunez, K. Uchida, and K. Suzuki, “Pepita: A design of robot pet interface for promoting interaction,” 10 2013, pp. 552–561.
- [172] M. Suguitan and G. Hoffman, “Blossom: A tensile social robot design with a handcrafted shell,” 03 2018, pp. 249–250.
- [173] J.-T. Lee, R. P. C. J. Rajapakse, Y.-P. Hung, Y.-C. Mao, and Y. Tokuyama, “Haptdoll: An interactive device for tactile sensation with virtual companion doll,” in *Proceedings of the 2nd International Conference on Image and Graphics Processing*, ser. ICIGP ’19. New York, NY, USA: Association for Computing Machinery, 2019, pp. 125–131. [Online]. Available: <https://doi.org/10.1145/3313950.3313974>
- [174] J.-T. Lee, R. J. Rajapakse, Y.-P. Hung, and Y. Tokuyama, “The development of a virtual doll companion for haptic interaction,” in *2018 Nicograph International (NicoInt)*, 2018, pp. 92–92.
- [175] M. Bekoff, “Animal emotions: Exploring passionate naturescurrent interdisciplinary research provides compelling evidence that many animals experience such emotions as joy, fear, love, despair, and grief—we are not alone,” *BioScience*, vol. 50, no. 10, pp. 861–870, 2000.
- [176] N. J. Kohut, A. O. Pullin, D. W. Haldane, D. Zarrouk, and R. S. Fearing, “Precise dynamic turning of a 10 cm legged robot on a low

- friction surface using a tail,” in *2013 IEEE International Conference on Robotics and Automation*, 2013, pp. 3299–3306.
- [177] N. J. Kohut, A. O. Pullin, D. W. Haldane, D. Zarrouk, and R. S. Fearing, “Precise dynamic turning of a 10 cm legged robot on a low friction surface using a tail,” in *2013 IEEE International Conference on Robotics and Automation*. IEEE, 2013, pp. 3299–3306.
- [178] W. Saab, W. S. Rone, A. Kumar, and P. Ben-Tzvi, “Design and integration of a novel spatial articulated robotic tail,” *IEEE/ASME Transactions on Mechatronics*, vol. 24, no. 2, pp. 434–446, 2019.
- [179] W. S. Rone and P. Ben-Tzvi, “Continuum robot dynamics utilizing the principle of virtual power,” *IEEE Transactions on Robotics*, vol. 30, no. 1, pp. 275–287, 2014.
- [180] J. Saldien, B. Vanderborght, K. Goris, M. Van Damme, and D. Lefeber, “A motion system for social and animated robots,” *International Journal of Advanced Robotic Systems*, vol. 11, no. 5, p. 72, 2014.
- [181] M. Marcet-Rius, E. Fàbrega, A. Cozzi, C. Bienboire-Frosini, E. Descout, A. Velarde, and P. Pageat, “Are tail and ear movements indicators of emotions in tail-docked pigs in response to environmental enrichment?” *Animals*, vol. 9, no. 7, p. 449, 2019.
- [182] D. Löffler, N. Schmidt, and R. Tscharn, “Multimodal expression of artificial emotion in social robots using color, motion and sound,” in *2018 13th ACM/IEEE International Conference on Human-Robot Interaction (HRI)*. IEEE, 2018, pp. 334–343.
- [183] M. Suomalainen, A. Q. Nilles, and S. M. LaValle, “Virtual reality for robots,” in *2020 IEEE/RSJ International Conference on Intelligent Robots and Systems (IROS)*. IEEE, 2020, pp. 11 458–11 465.
- [184] H. Katsuno and D. White, “Haptic creatures: Tactile affect and human-robot intimacy in japan,” in *Consumer Culture Theory in Asia*. Taylor & Francis, 2022.
- [185] G. Castellano, S. D. Villalba, and A. Camurri, “Recognising human emotions from body movement and gesture dynamics,” in *International conference on affective computing and intelligent interaction*. Springer, 2007, pp. 71–82.

- [186] M. Lhommet and S. C. Marsella, “19 expressing emotion through posture and gesture,” *The Oxford handbook of affective computing*, p. 273, 2014.
- [187] J. Saldien, “Development of the huggable social robot probot: on the conceptual design and software architecture,” Ph.D. dissertation, Vrije Universiteit Brussel. Faculty of Engineering, 2009.
- [188] W. D. Stiehl, J. K. Lee, C. Breazeal, M. Nalin, A. Morandi, and A. Sanna, “The huggable: a platform for research in robotic companions for pediatric care,” in *Proceedings of the 8th International Conference on interaction Design and Children*, 2009, pp. 317–320.
- [189] Y.-H. Nho, J.-W. Seo, W.-J. Seol, and D.-S. Kwon, “Emotional interaction with a mobile robot using hand gestures,” in *2014 11th International Conference on Ubiquitous Robots and Ambient Intelligence (URAI)*. IEEE, 2014, pp. 506–509.
- [190] H. Taherdoost, “Designing a questionnaire for a research paper: A comprehensive guide to design and develop an effective questionnaire,” *Asian Journal of Managerial Science*, vol. 11, no. 1, pp. 8–16, 2022.
- [191] R. Suzuki, A. Karim, T. Xia, H. Hedayati, and N. Marquardt, “Augmented reality and robotics: A survey and taxonomy for ar-enhanced human-robot interaction and robotic interfaces,” in *CHI Conference on Human Factors in Computing Systems*, 2022, pp. 1–33.
- [192] F. Quek, “Embodiment and multimodality,” in *Proceedings of the 8th international conference on Multimodal interfaces*, 2006, pp. 388–390.
- [193] O. C. Biermann, D. Ajisafe, and D. Yoon, “Interaction design for vr applications: Understanding needs for university curricula,” in *CHI Conference on Human Factors in Computing Systems Extended Abstracts*, 2022, pp. 1–7.
- [194] E. L. M. Naves *et al.*, “Attention detection in virtual environments using eeg signals: A scoping review,” *Frontiers in physiology*, p. 2051, 2021.

# Publications

- [1] **(Journal)** L. J. Tun, R. J. Rajapakse, and K. Miyata, "Haptwarp: Implementation of bend, twist, and press manipulations for intuitive interaction in between the virtual and physical world," *Journal of Robotics, Networking and Artificial Life*, vol. 8, pp. 263-268, 2021. [Online]. Available: <https://doi.org/10.2991/jrnal.k.211108.007>
- [2] **(Conference)** L. Jen Tun, R. P. C. J. Rajapakse, and K. Miyata, HaptWarp: Soft Printable and Motion Sensible Game Controller, *Proceedings of International Conference on Artificial Life and Robotics*, vol. 26, pp. 732-735, Jan. 2021.
- [3] **(Conference)** L. J. Tun, R. P. C. Janaka Rajapakse, Y. -P. Hung and K. Miyata, "Implementations of the Gesture-based Immersive Interaction and ML-driven Sound Generation for Haptic Companion Doll," *2020 IEEE International Conference on Artificial Intelligence and Virtual Reality (AIVR)*, 2020, pp. 375-379, doi: 10.1109/AIVR50618.2020.00078.
- [4] **(Conference)** J. T. Lee, R. P. C. J. Rajapakse and K. Miyata, "An Empirical Study on Intuitive Gesture Manipulation in Virtual Reality," *2022 8th International Conference on Virtual Reality (ICVR)*, 2022, pp. 216-224, doi: 10.1109/ICVR55215.2022.9848105.
- [5] **(Conference)** J. -T. Lee, R. P. C. J. Rajapakse and K. Miyata, "EEG-based Evaluation on Intuitive Gesture Interaction in Virtual Environment," *2022 International Conference on Cyberworlds (CW)*, 2022, pp. 213-217, doi: 10.1109/CW55638.2022.00050.