

Title	Performance Analysis and Evaluation for Multi-Traffic Networks Using Priority Based Controlled Available Bit Rates
Author(s)	Wuyi, Yue; Dequan, Yue; Huachen, Zhang; Fengsheng, Tu
Citation	
Issue Date	2005-11
Type	Conference Paper
Text version	publisher
URL	http://hdl.handle.net/10119/3816
Rights	2005 JAIST Press
Description	The original publication is available at JAIST Press http://www.jaist.ac.jp/library/jaist-press/index.html , IFSR 2005 : Proceedings of the First World Congress of the International Federation for Systems Research : The New Roles of Systems Sciences For a Knowledge-based Society : Nov. 14-17, 2006, Kobe, Japan, Symposium 3, Session 1 : Intelligent Information Technology and Applications Men and Computing

Performance Analysis and Evaluation for Multi-Traffic Networks Using Priority Based Controlled Available Bit Rates

Wuyi Yue¹, Dequan Yue², Huachen Zhang³ and Fengsheng Tu³

¹Department of Information Science and Systems Engineering
Konan University, Kobe 658-8501 Japan
yue@konan-u.ac.jp

²Department of Statistics, College of Sciences, Yanshan University
Qinhuangdao 066004 China
ydq@ysu.edu.cn

³Department of Automation, School of Information Technology and Sciences
Nankai University, Tianjin 300071 China
hc Zhang@nankai.edu.cn, tufs@nankai.edu.cn

ABSTRACT

In this paper, we consider a multi-traffic network system with a transmission link shared by Available Bit Rate (ABR) application for non-real time traffic and Variable Bit Rate (VBR) application for real time traffic. It is assumed that the VBR traffic has a higher transmission priority than the ABR traffic. We propose a new feedback control method to control the flow of the ABR traffic. In this method, the ABR source has multiple states and the number of cells transmitted by the ABR source is controlled by the feedback based on the congestion state of the buffer. By using the Markov chain method, we establish a tractable analytical model for the system. We give some iterative formulas for calculating the transition probabilities. Then, based on the analysis, we calculate the cell loss probability and the utilization of the network system. The impact of several parameters on the system performance is presented through some simulation results.

Keywords: ABR, VBR, performance analysis and evaluation, loss probability, utilization

1. INTRODUCTION

Asynchronous Transfer Mode (ATM) is the first switching technology that can support both fixed bandwidth services similar to circuit switching, and highly

variable bandwidth services similar to packet switching, in a single integrated environment [1]. ATM networks are expected to support applications with diverse traffic characteristics and Quality of Service (QoS) requirements such as data transfer, voice, video, multi-media conferencing and real time control. This requires a QoS system that differentiates services according to the level of quality required.

The Available Bit Rate (ABR) service in ATM networks is intended for non-real time traffic, where delay can be tolerated. Yet, it can also efficiently co-exist with other service classes such as Constant Bit Rate (CBR) and Variable Bit Rate (VBR) which are intended for real time traffic.

Since CBR and VBR traffic rates will fluctuate in time, the ABR sources should need to their rates according to fluctuations in order to utilize the entire remaining capacity or avoid cell losses. Therefore, it is necessary to control the ABR traffic sources. Over the years, there have been two major flow control mechanisms for the ABR services: the rate based flow control and the credit based flow control [2]-[5].

[2] considered an ATM network system with a transmission link shared by VBR and ABR applications and studied the effects of various time scales on the management of ABR traffic using a feedback based flow control scheme. In this system, a feedback carrying information about the available bandwidth is

transmitted to the ABR source when the bandwidth availability for the ABR source changes. The ABR transmission rates are then determined by the feedback based on the VBR transmission rates. However, the feedback does not contain the information about the buffer.

[3] proposed a proportional feedback scheme for ATM networks. There is a proportional multiplier in the system. All the inputs to the multiplier are multiplied by a factor, which is updated by the feedback from the receiver before forwarding the inputs. The feedback contains the information about the number of cells in the buffer. However, [3] only presented a continuous time model to analyze the system.

In this paper, we apply the schemes utilized in [2] and [3] to consider a system model of a multi-traffic network under a new feedback control method for ABR service. In this method, the ABR source has multiple states and the number of cells transmitted by the ABR source is controlled by the feedback based on the congestion state of the buffer.

The rest of the paper is organized as follows. In Section 2, we describe the system model. In Section 3, we establish a tractable analytical model for the system and give some iterative formulas for calculating the transition probabilities of a Markov chain. Then, based on the analysis, we calculate the cell loss probability and the utilization of the network system. In Section 4, by simulating results, we show how various operational parameters might impact on the system. Conclusions are given in Section 5.

2. SYSTEM MODEL

In this section, we consider the system introduced in [2]. In this system, there is a transmission link shared by the Available Bit Rate (ABR) application for non-real time traffic and the Variable Bit Rate (VBR) application for real time traffic. The network access node is assumed to have a finite buffer of capacity C for the temporary storage of the cells. If the buffer is full, however, the ABR cells will be blocked and cleared from the system.

In this system, we consider that the VBR traffic has

a higher transmission priority than the ABR traffic. If VBR cell and ABR cell arrive at the same time, then the VBR cell will be transmitted firstly, while the ABR cell will enter the buffer to wait. When there are no VBR cells to transmit, the ABR cells can be transmitted according first-in first-out discipline.

The time axis is slotted and the frame has a fixed length of L slots. According to the late arrival definition, it is assumed that cell departures occur at the beginning of a slot and the cell arrivals occur at the end of a slot. It is possible that a cell arriving at a slot will enter transmission at once if the system is empty and depart immediately.

Let t_k denote the beginning time instant of the k th frame, $k = 1, 2, \dots$, and let $S_k = s_k, s_k = 0, 1$ be a random variable to denote the VBR source activity level or state. For example: let $s_k = 1$ denote the traffic at a heavier level and $s_k = 0$ denote the traffic at a lighter level at t_k . We call s_k the state of the VBR source. Changes of the state s_k occur only at the boundaries of the frame.

Let $r_v(s_k)$ denote the probability of transmitting one cell by the VBR source in a slot of the k th frame when the state of the VBR source is s_k at the k th frame. When $s_k = 0$ (or $=1$), then the transmitting rate of the VBR source at the k th frame is $r_v(0)$ (or $r_v(1)$). In the above example, it can be assumed that $r_v(1) > r_v(0)$.

The cell arrival process of the VBR is modeled as a Markov Modulated Bernuolli Process (MMBP). The VBR cells can arrive in an arbitrary slot. Let $A(s_k)$ represent the number of VBR cells arriving in one slot of the k th frame. Therefore, $A(s_k)$ is given by

$$A(s_k) = \begin{cases} 1, & \text{with probability } r_v(s_k) \\ 0, & \text{with probability } 1 - r_v(s_k). \end{cases}$$

We assume the ABR traffic source to have M states. We call $z_k = 1, 2, \dots, M$ the state of the ABR source at the k th frame. The number of ABR cells transmitted varies with the state z_k of the ABR source. The higher the level of states of the ABR source is, the larger the number of ABR cells transmitted will be. When the state of the ABR source is in z_k , then

the ABR source can transmit a block of $z_k B$ cells per frame of length L slots, where the batch size $B \geq 0$ is an integer constant as a system parameter. Therefore, the probability of transmitting one cell in average by the ABR source in a slot of the k th frame is given by $r_a(z_k) = \frac{z_k B}{L}$.

The changes of the state of the ABR source are controlled by the feedback based on the buffer states of the system. It is assumed that the changes in the ABR states occur only at frame boundaries in accordance with the feedback. This means that the changes in the ABR states cannot occur during a frame.

We use two critical numbers g_1 and g_2 to characterize the congestion of the buffer, $0 \leq g_1 \leq g_2$. If the queue length of the buffer is less than or equal to g_1 , i.e., the buffer is in low congestion state I, then it sends signal $+1$. If the queue length of the buffer is greater than g_1 and less than or equal to g_2 , i.e., the buffer is in medium congestion state II, then it sends signal 0 . If the queue length of the buffer is larger than g_2 , i.e., the buffer is in high congestion state III, then it sends signal -1 .

Assume that the ABR source is in state z_k at time t_k . Then if the ABR source receives the signal $+1$, then it will be in state $z_k + 1$ at time $t_k + L$ for $z_k = 1, 2, \dots, M-1$, and in state M for $z_k = M$. If it receives the signal -1 , then it will be in state $z_k - 1$ at time $t_k + L$ for $z_k = 2, 3, \dots, M$, and in state 1 for $z_k = 1$. If it receives the signal 0 or does not receive new signals, then it will be in state z_k at time $t_k + L$, i.e., the state of the ABR source does not change at time $t_k + L$, where L is the number of slots in a frame. A queueing model of the network access node is shown in Fig. 1.

3. PERFORMANCE ANALYSIS

In this section, we first establish an analytic model by using the Markov chain method and give some iterative formulas for calculating the transition probabilities. Then, based on the analysis, we calculate the cell loss probability and the utilization of the system.

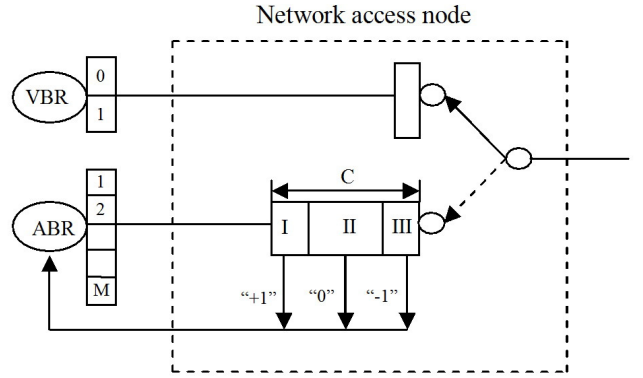

Figure 1: Queueing model of network access node.

Let $Z_k = z_k$, $z_k = 1, 2, \dots, M$ and $Q_k = q_k$, $q_k = 0, 1, \dots, C$ be random variables to denote the ABR source state and the queue length of the buffer at the beginning time t_k of the k th frame, respectively. Then, we have a 3-dimensional stochastic process $\{(S_k, Z_k, Q_k), k = 1, 2, \dots\}$ which is embedded at the beginning of frame $\{t_k, k = 1, 2, \dots\}$. It is easy to see that $\{(S_k, Z_k, Q_k), k = 1, 2, \dots\}$ is a Markov chain with state space given by

$$\Omega = \{(s_k, z_k, q_k), s_k = 0, 1, z_k = 1, 2, \dots, M, q_k = 0, 1, \dots, C\}$$

where M is the state of the ABR source and C is the capacity of the buffer.

Let $P(s_{k+1}, z_{k+1}, q_{k+1} | s_k, z_k, q_k)$ be the transition probability that the Markov chain $\{(S_k, Z_k, Q_k), k=1, 2, \dots\}$ moves from state (s_k, z_k, q_k) at time t_k , to state $(s_{k+1}, z_{k+1}, q_{k+1})$ at time t_{k+1} . It is easy to see that $\{S_{k+1}=s_{k+1}\}$ and $\{Z_{k+1}=z_{k+1}\}$ are independent with $\{S_k=s_k, Q_k=q_k\}$ and $\{S_k=s_k\}$, respectively, and that $\{Q_{k+1}=q_{k+1}\}$ is independent with $\{S_{k+1}=s_{k+1}, Z_{k+1}=z_{k+1}\}$. Then $P(s_{k+1}, z_{k+1}, q_{k+1} | s_k, z_k, q_k)$ can be expressed as follows:

$$P(s_{k+1}, z_{k+1}, q_{k+1} | s_k, z_k, q_k) = P(s_{k+1} | s_k) \cdot P(z_{k+1} | z_k, q_k) P(q_{k+1} | s_k, z_k, q_k). \quad (1)$$

The probabilities on the right side of Eq. (1) can be calculated separately as the following.

Let $p_s(s_k)$ denote the probability that S_k changes at the end of the k th frame, and at the beginning

of the k th frame it was in state s_k . Since the VBR cell arrival process is an MMBP, $\{S_k, k=0, 1\}$ is a two state Markov chain. It is easy to see from the definition of $p_s(s_k)$ that

$$\begin{aligned} P(s_{k+1} = 1 \mid s_k = 0) &= p_s(0), \\ P(s_{k+1} = 0 \mid s_k = 0) &= 1 - p_s(0), \\ P(s_{k+1} = 0 \mid s_k = 1) &= p_s(1), \\ P(s_{k+1} = 1 \mid s_k = 1) &= 1 - p_s(1). \end{aligned}$$

Moreover, if $q_k \leq g_1$, then we have

$$P(z_{k+1} = z \mid z_k, q_k) = \begin{cases} 1, & \text{if } z = z_k + 1 \\ 0, & \text{otherwise} \end{cases} \quad (2)$$

for $z_k = 1, 2, \dots, M-1$, and $P(z_{k+1} = M \mid z_k = M, q_k) = 1$. If $g_1 < q_k \leq g_2$, then we have

$$P(z_{k+1} = z \mid z_k, q_k) = \begin{cases} 1, & \text{if } z = z_k \\ 0, & \text{otherwise} \end{cases} \quad (3)$$

for $z_k = 1, 2, \dots, M$. If $q_k > g_2$, then we have

$$P(z_{k+1} = z \mid z_k, q_k) = \begin{cases} 1, & \text{if } z = z_k - 1 \\ 0, & \text{otherwise} \end{cases} \quad (4)$$

for $z_k = 2, 3, \dots, M$, and $P(z_{k+1} = 1 \mid z_k = 1, q_k) = 1$.

Let $q_{k,i}$ denote the queue length at the end of the i th slot of the k th frame. Let $P_A(q_{k,i+1} \mid s_k, z_k, q_{k,i})$ and $P_B(q_{k,i+1} \mid s_k, z_k, q_{k,i})$ denote the one slot transition probabilities from $q_{k,i}$ to $q_{k,i+1}$ over the first $z_k B$ slots of the k th frame and the remaining $L - z_k B$ slots, respectively. They are given as follows:

$$P_A(q_{k,i+1} \mid s_k, z_k, q_{k,i}) = \begin{cases} P(A(s_k) = q_{k,i+1} - q_{k,i}), & 0 \leq q_{k,i} \leq C-1, \\ q_{k,i+1} = q_{k,i}, q_{k,i} + 1 & \\ 1, & q_{k,i} = q_{k,i+1} = C \\ 0, & \text{otherwise,} \end{cases} \quad (5)$$

$$P_B(q_{k,i+1} \mid s_k, z_k, q_{k,i}) = \begin{cases} 1, & q_{k,i} = q_{k,i+1} = 0 \\ P(A(s_k) = q_{k,i+1} - q_{k,i} + 1), & 1 \leq q_{k,i} \leq C, \\ 0, & q_{k,i+1} = q_{k,i} - 1, q_{k,i} \\ & \text{otherwise.} \end{cases} \quad (6)$$

Then, $P(q_{k+1} \mid s_k, z_k, q_k)$ can be calculated through these two probabilities as follows:

$$P(q_{k+1} \mid s_k, z_k, q_k) = \sum_{q_{k,z_k B}=0}^C P_A(q_{k,z_k B} \mid s_k, z_k, q_k)$$

$$\cdot P_B(q_{k+1} \mid s_k, z_k, q_{k,z_k B}) \quad (7)$$

where the two probabilities $P_A(q_{k,z_k B} \mid s_k, z_k, q_k)$ and $P_B(q_{k+1} \mid s_k, z_k, q_{k,z_k B})$ can be calculated iteratively using one slot transition probabilities $P_A(q_{k,i+1} \mid s_k, z_k, q_{k,i})$ and $P_B(q_{k,i+1} \mid s_k, z_k, q_{k,i})$, respectively. For example,

$$P_A(q_{k,z_k B} \mid s_k, z_k, q_k) = \sum_{q_{k,1}=0}^C P_A(q_{k,1} \mid s_k, z_k, q_k) \cdot P_A(q_{k,z_k B} \mid s_k, z_k, q_{k,1}).$$

After calculating the transition probabilities $P(s_{k+1}, z_{k+1}, q_{k+1} \mid s_k, z_k, q_k)$, $k=1, 2, \dots$, the steady state probability distribution $\pi(s_k, z_k, q_k)$ can be solved from the matrix equations: $\pi \mathbf{P} = \pi$ and $\pi \mathbf{e} = 1$, where \mathbf{P} is a $2M(C+1) \times 2M(C+1)$ matrix of the transition probability $P(s_{k+1}, z_{k+1}, q_{k+1} \mid s_k, z_k, q_k)$. π is a $2M(C+1)$ -dimensional row vector with elements $\pi(s_k, z_k, q_k)$, and \mathbf{e} is a column vector whose elements are all equal to 1. By using the matrix technique we presented in [6], we can obtain the explicit expression of the transition probability matrix \mathbf{P} .

In the following, we calculate the ABR cell loss probability and the utilization of the transmission link. Let $\bar{L}(s_k, z_k, q_k)$ and $\bar{M}(s_k, z_k, q_k)$ denote the average number of ABR cells lost and arrived over the frame at the beginning of which the process $\{(S_k, Z_k, Q_k), k=1, 2, \dots\}$ is in state (s_k, z_k, q_k) , respectively. Then, the ABR cell loss probability denote by LP is given as follows:

$$LP = E \left[\frac{\bar{L}(s_k, z_k, q_k)}{\bar{M}(s_k, z_k, q_k)} \right]. \quad (8)$$

Let $L_i(s_k, z_k, q_k)$ and $M_i(s_k, z_k, q_k)$ denote the number of ABR cells lost and arrived at the i th slot of the k th frame in state (s_k, z_k, q_k) , respectively. It is easy to see that

$$M_i(s_k, z_k, q_k) = \begin{cases} 0, & \text{if } i > z_k B \\ 1, & \text{otherwise} \end{cases} \quad (9)$$

and

$$L_i(s_k, z_k, q_k) = \begin{cases} A(s_k), & \text{if } q_{k,i-1} = C, \\ & i \leq z_k B \\ 0, & \text{otherwise.} \end{cases} \quad (10)$$

Therefore,

$$\begin{aligned}\bar{M}(s_k, z_k, q_k) &= E \left[\sum_{i=1}^{z_k B} M_i(s_k, z_k, q_k) \right] \\ &= z_k B\end{aligned}\quad (11)$$

and

$$\begin{aligned}\bar{L}(s_k, z_k, q_k) &= E \left[\sum_{i=1}^{z_k B} L_i(s_k, z_k, q_k) \right] \\ &= \sum_{i=1}^{z_k B} P_A(q_{k,i-1} = C | s_k, z_k, q_k) \\ &\quad \cdot E[A(s_k)] \\ &= \sum_{i=1}^{z_k B} P_A(q_{k,i-1} = C | s_k, z_k, q_k) \\ &\quad \cdot r_v(s_k).\end{aligned}\quad (12)$$

Taking the expectation over all possible states, we get the ABR cell loss probability LP given by

$$\begin{aligned}LP &= \sum_{s_k=0}^1 \sum_{z_k=1}^M \sum_{q_k=0}^C \pi(s_k, z_k, q_k) \frac{1}{z_k B} \\ &\quad \cdot \sum_{i=1}^{z_k B} P_A(q_{k,i-1} = C | s_k, z_k, q_k) r_v(s_k).\end{aligned}\quad (13)$$

The utilization of the transmission link can be calculated by considering the busy probability of the link at one slot of the frame in which the process $\{(S_k, Z_k, Q_k), k=1, 2, \dots\}$ is in state (s_k, z_k, q_k) and taking the expectation over all possible states.

Let $U_i(s_k, z_k, q_k)$ and $\bar{U}(s_k, z_k, q_k)$ denote the busy probability of the link at the i th slot of the k th frame and the average busy probability of the link at the k th frame in which the process is in state (s_k, z_k, q_k) , respectively. It is easy to see that

$$U_i(s_k, z_k, q_k) = \begin{cases} 1, & i \leq z_k B \\ 1 - P(q_{k,i} = 0 | s_k, z_k, q_k) \\ \quad \cdot P(A(s_k) = 0), & i > z_k B. \end{cases}\quad (14)$$

Hence,

$$\begin{aligned}\bar{U}(s_k, z_k, q_k) &= \frac{1}{L} \sum_{i=1}^L U_i(s_k, z_k, q_k) \\ &= 1 - \frac{1}{L} [1 - r_v(s_k)] \sum_{i=z_k B+1}^L\end{aligned}$$

$$\begin{aligned}\cdot \sum_{q_{k,z_k B}=0}^C P_A(q_{k,z_k B} | s_k, z_k, q_k) \\ \cdot P_B(q_{k,i} = 0 | s_k, z_k, q_k, z_k B).\end{aligned}\quad (15)$$

Taking the expectation over all possible states, we get utilization U of the transmission link given by

$$U = \sum_{s_k=0}^1 \sum_{z_k=1}^M \sum_{q_k=0}^C \pi(s_k, z_k, q_k) \bar{U}(s_k, z_k, q_k)\quad (16)$$

where $\bar{U}(s_k, z_k, q_k)$ is given by Eq. (15).

4. NUMERICAL RESULTS

In this section, we present some simulation results to demonstrate how the various parameters of the system influence the loss probability LP and the utilization U . In all numerical results, we assume that $r_v(1) = 0.8$, $r_v(0) = 0.4$, and $p_s(1) = p_s(0) = 0.6$ by referring to [2]. The simulation results of LP and U are illustrated in Figs. 2-5.

In Fig. 2, we fix the capacity of the buffer $C = 500$, the number of ABR source states $M = 10$, the length of the frame $L = 2000$, the lower critical number $g_1 = 50$ and the upper critical number $g_2 = 100$, and display the LP and U by varying the batch size B .

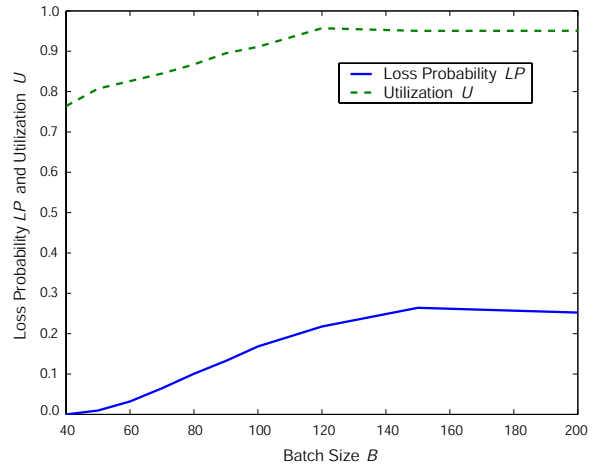

Figure 2: Loss probability LP and utilization U versus batch size B with $C = 500$, $M = 10$, $L = 2000$, $g_1 = 50$ and $g_2 = 100$.

In Fig. 3, we fix $C = 500$, $B = 50$, $L = 2000$, $g_1 = 50$ and $g_2 = 100$, and display the LP and U

by varying the number of ABR source states M . We can see from Fig. 1 and Fig. 2 that the loss probability LP and the utilization U initially increase as the batch size B or the number of ABR source states M increases, but they rarely change when B or M exceed a threshold. This is because that the ABR cells transmitted with an ABR state increase as B or M increases, it causes the increasing of LP and U . However, when B or M becomes larger, the buffer will be in a higher congestion state. Thus, the ABR source will go from a heavier state to a lower state according to the feedback information. As a sequence, LP and U will be kept stable.

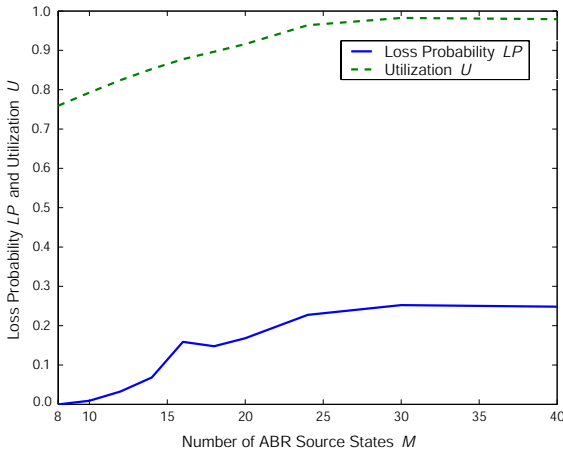

Figure 3: Loss probability LP and utilization U versus number of ABR source states M with $C = 500$, $B = 50$, $L = 2000$, $g_1 = 50$ and $g_2 = 100$.

In Fig. 4, we fix $B = 50$, $M = 10$, $L = 2000$, $g_1/C = 0.2$ and $g_2/C = 0.6$, and display the LP and U by varying the capacity of the buffer C . Intuitively, the critical numbers g_1 and g_2 should increase as C increases. Therefore, it is reasonable that we fix the ratios $g_1/C = 0.2$ and $g_2/C = 0.6$. Fig. 4 shows that: LP decreases significantly as the capacity C of the buffer increases but U rarely changes as C increases. Intuitively, the larger the capacity C of the buffer is, the less congested the buffer will be. This results in the decreasing of LP .

In Fig. 5, we fix $B = 60$, $M = 10$, $C = 1000$, $g_1 = 100$ and $g_2 = 200$, and display the $100LP$ and U by varying the length of the frame L . Fig. 5 shows that: LP decreases significantly and U decreases slightly as

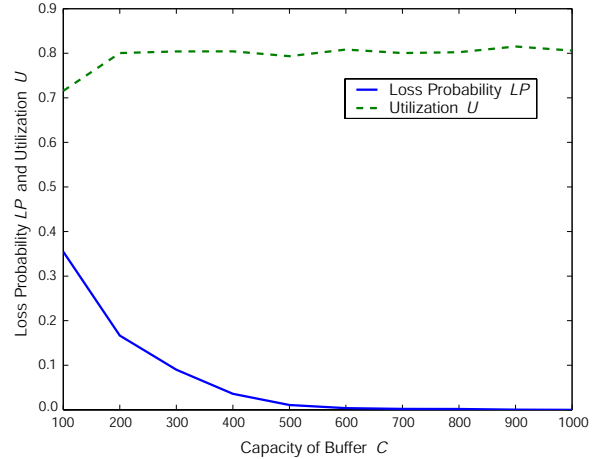

Figure 4: Loss probability LP and utilization U versus capacity of buffer C with $B = 50$, $M = 10$, $L = 2000$, $g_1/C = 0.2$ and $g_2/C = 0.6$.

the length of the frame L increases. Intuitively, the larger the length of the frame L , the less frequently the VBR source states change. Thus, more ABR cells have the opportunity to be serviced. As a sequence, the buffer will be less congested. This results in the decreasing of LP .

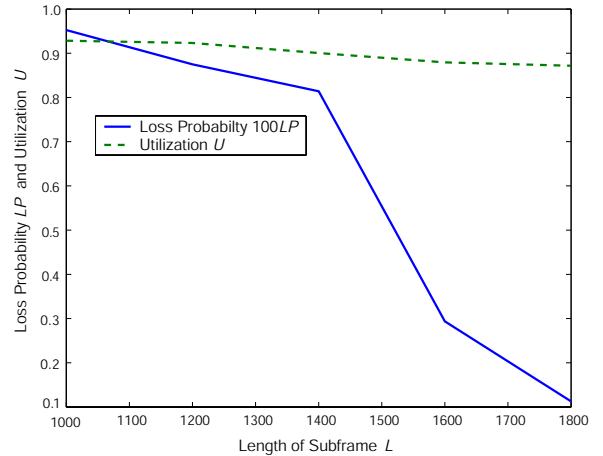

Figure 5: Loss probability LP and utilization U versus length of frame L with $C = 1000$, $B = 60$, $M = 10$, $g_1 = 100$ and $g_2 = 200$.

5. CONCLUSIONS

We have analyzed a system with a transmission link shared by Available Bit Rate (ABR) and Variable

Bit Rate (VBR) applications. We proposed a new feedback control method to control the flow of the ABR traffic. We established a tractable analytical model for the system and obtained some iterative formulas for calculating the transition probabilities. Based on this, we have presented the calculation of the cell loss probability and the utilization of the system. Furthermore, we investigated the impact of several parameters on the system by analyzing the numerical results. The numerical results indicated that: (i) B and M affect both LP and U , but the impact is not significant when the values of B and M are large enough, (ii) C and L only slightly affect the utilization U , but affect the loss probability LP significantly.

ACKNOWLEDGMENT

This work was supported in part by the National Natural Science Foundation of China (No. 60074018, No. 10271102) and the Natural Science Foundation of Hebei Province (No. A2004000185), China, and was supported in part by GRANT-IN-AID FOR SCIENTIFIC RESEARCH (No. 16560350) and MEXT. ORC (2004-2008), Japan.

REFERENCES

- [1] P. Newman, "Traffic management for ATM local area networks," *IEEE Communications Magazine*, Vol. 32, No. 8, pp. 44-50, 1994.
- [2] I. Dağ and I. Stavrakakis, "Evaluation of ABR traffic management under various system time scales," *Computer Networks and ISDN systems*, Vol. 29, pp. 2013-2117, 1998.
- [3] W. K. Lai, C. C. Hwang and W. J. Hsiao, "A proportional feedback scheme for ATM networks," *Information Sciences*, Vol. 110, pp. 237-253, 1998.
- [4] F. Bonomi and R. Morris, "The rate based flow control framework for the available bit rate ATM service," *IEEE Network*, Vol. 9, No. 2, pp. 25-39, 1995.
- [5] H. T. Kung and R. Morris, "Credit based flow control for ATM networks," *IEEE Network*, Vol. 9, No. 2, pp. 40-48, 1995.
- [6] D. Yue, H. Zhang and F. Tu, "The transition probability matrix of a Markov chain model in an ATM network," *Journal of System Sciences and Complexity*, Vol. 16, No. 4, pp. 506-512, 2003.