

| | |
|--------------|--|
| Title | An algebraic approach to linguistic hedges in Zadeh's fuzzy logic |
| Author(s) | Nguyen, Ho C.; Huynh, V. Nam |
| Citation | Fuzzy Sets and Systems, 129(2): 229-254 |
| Issue Date | 2002-07-16 |
| Type | Journal Article |
| Text version | author |
| URL | http://hdl.handle.net/10119/4996 |
| Rights | NOTICE: This is the author's version of a work accepted for publication by Elsevier. Nguyen C. Ho and Huynh V. Nam, Fuzzy Sets and Systems, 129(2), 2002, 229-254, http://dx.doi.org/10.1016/S0165-0114(01)00147-6 |
| Description | |

AN ALGEBRAIC APPROACH TO LINGUISTIC HEDGES IN ZADEH'S FUZZY LOGIC¹

Nguyen C. Ho^a and Huynh V. Nam^{b,2}

^a *Institute of Information Technology, Vietnam NCST.*

P.O. Box 626 Bo Ho, Hanoi 10000, Vietnam.

Fax: 84-4-7715529. E-mail: ncaho@hn.vnn.vn

^b *Dept. of Computer Science, Pedagogical University of Vinh, 170-An Duong Vuong, Vinh, Vietnam.*

170-An Duong Vuong, Vinh, Vietnam.

Fax: 84-56-846089. E-mail: nv_huynh@yahoo.com

Abstract.

The paper addresses the mathematical modelling of domains of linguistic variables, i.e. term-sets of linguistic variables, in order to obtain a suitable algebraic structure for the set of truth values of Zadeh's fuzzy logic. We shall give a unified algebraic approach to the natural structure of domains of linguistic variables, which was proposed by Ho and Wechler in [8] and, then, by Ho and Nam in [6,7]. In this approach, every linguistic domain can be considered as an algebraic structure called hedge algebra, because properties of its unary operations reflect semantic characteristics of linguistic hedges. Many fundamental properties of RH_algebras are examined, especially it is shown that every RH_algebra of a linguistic variable with a chain of the primary terms is a distributive lattice. RH_algebras with exactly two distinct primary terms, one being an antonym of the other, will also be investigated and they will be called symmetrical RH_algebras. It is shown that a class of finite symmetrical RH_algebras has a rich enough algebraic structure.

Keywords: Approximate reasoning, Fuzzy logic, Linguistic variable, Hedge algebra, RH_algebra, Distributive lattice.

¹) Accepted for publication in *Fuzzy Sets and Systems*

²) Corresponding author, on leave at Japan Advanced Institute of Science and Technology. Email: huynh@jaist.ac.jp

1 INTRODUCTION

The theory of approximate reasoning was introduced and developed by Zadeh in the 1970s (see, e.g., [38,39]), and it is based on the notions of linguistic variables and fuzzy logics.

Formally, a linguistic variable is characterised by a quintuple $(X, T(X), U, R, M)$, where X is the name of variable such as age variable *Age*, truth variable *Truth* etc., $T(X)$ denotes the **term-set** of X , that is, the set of linguistic values of the linguistic variable; U is a universe of discourse of the base variable; R is a syntactic rule for generating linguistic terms of $T(X)$, and M is a semantic rule assigning to each linguistic term a fuzzy set on U .

As well known, the values of a linguistic variable are generated from primary terms (e.g. *young* and *old* in the case of linguistic variable *Age*), by various hedges (e.g. *very*, *more or less*, etc.) and connectives (e.g. *AND*, *OR*).

According to Zadeh's idea [37–40], one of the most important characteristic of linguistic variables is that the meaning of the primary terms (also called primary generators) is context-dependent, whereas the meaning of the hedges and connectives is not. In addition, another important characteristic of linguistic variables is the universality of their structure, i.e. most linguistic variables have the same basic structure in the sense that their respective linguistic values have the same expressions except the primary terms. Our investigations come from these important characteristics of linguistic variables and, moreover, from the intuitive meaning of vague concepts in natural language, which can be formulated in terms of a so-called semantically ordering relation, as well. More detailed discussions of the concept of a linguistic variable and its applications may be found in Zadeh [38–40] and references therein.

We know that humans reason by means of their own language and they can choose and decide alternatives by evaluating semantics of linguistic terms. The fundamental elements in human reasoning are sentences normally containing vague concepts, and these sentences have implicitly or explicitly a truth degree, which is often expressed also by linguistic values of linguistic truth variable. In connection with this, Rinks wrote in [33] that “verbal coding is a human way of repackaging material into a few chunks of rich information. Natural language is rather unique in this characteristic. Until recently, a unified theory for manipulating in a strict mathematical sense non-numerical-valued variables, such as linguistic terms, did not exist.”

So, it becomes natural to look for an algebraic structure capable of accounting for the notions of linguistic variables and hedges. This algebraic structure would thus provide a formal framework for a rigorous development of fuzzy logic.

In Zadeh's view of fuzzy logic, the truth-values are linguistic, e.g. of the form “*true*”, “*very true*”, “*more or less true*”, “*false*”, “*possible false*”, etc., which are expressible as values of the linguistic variable *Truth*, and the

rules of inference are approximate rather than exact. In this sense, approximate reasoning (also called fuzzy reasoning) is, for the most part, qualitative rather than quantitative in nature, and almost all of it falls outside of the domain of applicability of classical logic (see Zadeh [38,39]).

However, as stated in Dubois and Prade [11], “the approach is rather general, but on the one hand it does not say what particular types of approximate reasoning can be captured in this framework, and on the other hand, its situation with respect to logical formalisms remain unclear”.

In last years, a logical foundation of fuzzy logic and approximate reasoning proposed by L. A. Zadeh has been intensively investigated. These works on this subject can be observed in two trends. The first one is to establish an exact mathematical basis for fuzzy logic (see, e.g., [21,26,36]). The second one is to investigate a formal logical foundation of fuzzy inference and fuzzy reasoning methods (see, e.g., [10,13–15,20,23]). It is shown that fuzzy logic in narrow sense has an elegant formal logical basis and ones can establish several different logical calculus (based on t -norm based logical systems like Lukasiewicz’s logic, product logic, Gödel logic, ...) and fundamental inference rules of some deductive systems (see, e.g., [18,19,30]). Especially, Godo and Hajek in [19] pointed out that fuzzy inference can be considered as deduction in the strict logical sense and proposed to “understand much of Zadeh’s fuzzy logic inside many-sorted many-valued Pavelka-Lukasiewicz style rational quantification logic.”

As it can be observed in these works, there is a close relation between logical structure and the algebraic structure of truth values of the mentioned logic. Recall that every deductive system in classical or non-classical logic always determines an algebra of a certain class of universal algebras of the same category of the corresponding algebra of truth values (see, e.g., [31,32]). For example, every deductive system based on classical logics determines a Boolean algebra, which belongs to the same category of the two-element Boolean algebra of truth values $\mathbf{0}$ and $\mathbf{1}$; every deductive system based on intuitionistic logics considered in [31,32] determines a complete pseudo-Boolean algebra which has the same structure as that of the algebra of truth values of intuitionistic logics, and so on. This means that many characteristics of the logic, which a deductive system bases on, can be determined by the algebraic structure of the set of truth values of this logic.

Note that most of the works offered the logical formalization of fuzzy logic consider the unit interval $[0, 1]$, i.e. a linearly ordered set of real values, as the set of truth values. While the truth values of fuzzy logic in broad sense are fuzzy sets defined over the interval $[0, 1]$, which are designed to interpret the meaning of linguistic truth values. Therefore, it will be very useful if we can point out that the set of all linguistic truth values itself has a rich enough algebraic structure. If it is so, we may hope that it will provide specific characteristics for a kind of fuzzy logic.

To answer this question, an algebraic approach to the natural structure of the domains (i.e. term-sets) of

linguistic variables was proposed by Ho and Wechler ([4,8,9]), and it defines a class of algebras called hedge algebras. These algebras are proved to be complete lattices, but not distributive, and hence we are not able to express composed linguistic terms in the disjunction and conjunction normal forms. In addition, the structure of such algebras is rather rough. For example, let us consider the set of all possible truth values $T = \{ \textit{true}, \textit{false}, \textit{very true}, \textit{very false}, \textit{approximately true}, \textit{possibly true}, \textit{approximately true or possibly true}, \textit{approximately true and possibly true}, \textit{etc.} \}$. It can be shown from [9] that the linguistic term ‘*approximately true OR possibly true*’ will be expressed by ‘*approximately true*’ \cup ‘*possibly true*’ and it equals to ‘*true*’ in the structure of extended hedge algebra of the linguistic truth variable, where \cup is the join operation of this algebra. This is clearly unsuitable in nature. To overcome this problem, the so-called refined hedge algebras have been developed, based on an extension of the axiom system of the hedge algebras [6,7].

In the paper, we shall establish a unified algebraic approach to modelling of linguistic domains of linguistic variables and show that the obtaining structure is rich enough for the investigation of a kind of fuzzy logic.

This structure has some significant advantages.

1. It is a natural structure which models linguistic domains directly: Each term-set can be considered as an abstract algebra, in which primary terms such as “*true*” and “*false*” are regarded as generators (i.e. constants or zero-argument operations), hedges as unary operations. This algebra is equipped with a partially ordering relation \leq induced by the meaning of hedges, called semantically ordering relation. It orders the elements of the algebra based on semantic characteristics of linguistic hedges. So, elements of these algebras can be regarded as just linguistic terms and their relative meaning can be expressed in terms of the semantically ordering relation. It provides a possibility to introduce methods in linguistic reasoning that allow to handle linguistic terms directly (see [4,5]).
2. Term-sets of the linguistic truth variable may become an algebraic structure (see e.g. Theorem 6.1 and 6.2 of the paper). Recall that in the classical logic there is no semantic difference between two cases where we assign to every predicate a truth value in $\{0, 1\}$ in one case, or a truth value in an arbitrary Boolean algebra, in the other case. However, it is not the case of multiple-valued logic or fuzzy logic. Therefore, restricting the sets of truth values to hedge algebras, but not to the interval $[0, 1]$ or any partially ordered sets, will bring a certain benefit.
3. Because of specific structure of hedge algebras, their elements have specific semantics determined by ordering relation. It provides us an interesting way to define the notion of *fuzziness* of a vague concept x , based on the “size” of the set $LH(x)$ generated from the concept x by means of hedges and, then, to define a notion of *fuzziness of hedges*. It gives a possibility to introduce a clearly intuitive interpolation reasoning method in multiple conditional fuzzy reasoning.

It is worthwhile to emphasise that our approach is different from the MV_algebra-based approach to establishment of an algebraic basis for fuzzy logic. In fact, BL_algebras designed by P. Hajek [21] can be considered as a generalization of MV_algebras in order to capture certain intuitive characteristics of fuzzy logic, while the axiomatization of RH_algebras is based merely on natural semantic properties of linguistic hedges, which can be formulated in terms of an ordering relation. Furthermore, it will be shown that RH_algebras are not BL_algebras, in general.

The paper is organised as follows. In Section 2 we shall present a general construction of an abstract algebra for a given linguistic domain (or term-set). In Section 3 we introduce a unified axiomatization of RH_algebras and establish certain criteria for determining the relative position of elements in a RH_algebra and some fundamental properties of these algebras. In Section 4, a main property, which says that every RH_algebra with a chain of the primary terms is a distributive lattice, will be proved. In Section 5, a special class of RH_algebras with exactly one positive and one negative primary generator, called symmetrical RH_algebras, will be studied. Finite symmetrical RH_algebras and their properties, which may establish an algebraic basis for fuzzy logic, will be discussed in Section 6. Finally, some concluding remarks will be given in Section 7.

2 TERM-SETS OF LINGUISTIC VARIABLES FROM ALGEBRAIC POINT OF VIEW

2.1 Intuitive Properties of Hedges in Term of Ordering Relation

In his investigations of linguistic variables (e.g. [39]), Zadeh has always emphasised two most important characteristics of linguistic variables. The first is the context-independent meaning of hedges and connectives, whereas the meaning of the primary terms is context-dependent. The second is the universality of their structure. That is most linguistic variables possess the same basic structure in the sense that their respective linguistic values have the same expressions except for the primary terms. Therefore, a set of linguistic hedges (or hedges, for short) under consideration may be applied to many different linguistic variables, where the meanings of hedges are interpreted by operators on fuzzy sets [27,28,37–39]. From another viewpoint, these characteristics of linguistic variables and the meaning of hedges in natural language permit us to consider each domain of a linguistic variable as an algebraic structure called hedge algebra, say $AX = (X, G, H, \leq)$, where X is a set of values of a linguistic variable (regarded as a poset), G is the set of the primary terms of the linguistic variable and H is a set of unary operations representing linguistic hedges.

The structure of these algebras will be constructed, originated from semantic properties of hedges and linguistic terms. As the semantics of linguistic hedges seem to be complicated in natural, it is very difficult to define mathematically what a hedge is. However, analysing their intuitive meaning, we can observe the

following semantic properties which hedges should have:

1. In general, each linguistic primary term possesses an intuitive semantic tendency which can be expressed by a semantically ordering relation and one term possesses a meaning greater (or stronger) than another one. For example, for the truth variable *TRUTH*, according to their intuitive meaning we can write $True > False$, and observe that these primary terms have a converse semantic tendency: one term is called to be positive and the other is called to be negative. Here, ‘*True*’ is positive and ‘*False*’ is negative, and this positive-negative tendency can be characterised by $Very\ True > True$, while $Very\ False < False$. Similarly, each linguistic hedge possesses an intuitive meaning which can be expressed also by a semantically ordering relation, e.g. $Approximately\ True < True$, while $Very\ True > True$. In addition, if a hedge decreases the meaning (or the effect) of another hedge h , we say that k is negative w.r.t. h , and if k increases the meaning of h , we say that k is positive w.r.t. h . For example, since $Little\ AppTrue < AppTrue < True$, *Little* is said to be positive w.r.t. *App* and since $App\ True < Very\ App\ True < True$, *Very* is said to be negative w.r.t. *App*. Furthermore, we can observe that the negative-positive property of hedges h and k does not depend on the terms they apply to. In this example, it does not depend on the term “*True*”, that is, for every term x , we have either $App\ x < Very\ App\ x < x$ or $App\ x > Very\ App\ x > x$, and so on.
2. Hedges are modifiers or intensifiers and they have their degrees of modification and hence we can compare two hedges. For example, $Little > App$, since $Little\ True < App\ True < True$, and *App*, *Possibly* and *More-or-Less* seem to be incomparable. Thus, we may assume that the sets of hedges under consideration are posets.
3. An important semantic property of hedges is the so-called semantic heredity, which stems from the following observation: each hedge modifies merely a little the meaning of linguistic terms. That is, changing the meaning of a term, it preserves the original essential meaning of this term. Based on the semantically ordering relation, this property can be formulated in the following form: if the meaning of two terms in the forms hx and kx can be expressed by $hx \leq kx$, then $h'hx \leq k'kx$, for arbitrary hedges h' and k' . This means that h' and k' can not change the semantically ordering relationship between hx and kx , i.e. they preserve the relative meaning of hx and kx . This implies that $H(hx) \leq H(kx)$, where $H(u)$ denotes the set of all terms generated from u by means of hedges, i.e. $H(u) = \{\sigma u : \sigma \text{ is a chain of hedges, i.e. } \sigma \in H^*\}$. E.g. from $Little\ True \leq App\ True$ it follows that $Possibly\ Little\ True \leq Little\ App\ True$, and in general, $H(LittleTrue) \leq H(AppTrue)$.

These properties will be analysed and used in turn to develop RH_algebras and some of them will be selected

as axioms. At this moment, we can adopt the assumption that there exists an ordering relation on X and on H , where X and H are assumed to be disjoint sets. The semantic relation of these ordering relations will be formulated in Definition 2.1.

2.2 Term-Sets as Abstract Algebras.

In order to formalize this idea, let us consider an abstract algebra $AX = (X, G, \mathcal{O}, \leq)$, where X is a underlying set, G is the set of generators (or constants, i.e. zero-argument operations), \mathcal{O} is a set of one-argument operations and \leq is a partially ordering relation over X . X is intended to be interpreted as a term-set, G as a set of primary terms and special constants, \mathcal{O} as a set of hedges or modifiers and \leq as semantically ordering relation. Note that the set G may contain special constants such as $\mathbf{1}$, $\mathbf{0}$ and \mathbf{W} which are different from the primary terms and understood as “*absolutely true*”, “*absolutely false*” and the “*neutral*”, respectively. These constants can be characterized by the conditions that $hc = c$ for all $h \in \mathcal{O}, c \in \{\mathbf{1}, \mathbf{W}, \mathbf{0}\}$ and $\mathbf{1} > \mathbf{W} > \mathbf{0}$. Since every h in \mathcal{O} can be considered as a mapping from X into X and several operations can be used in concatenation, for convenience the image of an element x in X under h will be denoted by hx instead of $h(x)$. And therefore the result of the applying operations $h_1, h_2, \dots, h_n \in \mathcal{O}$ to an element $x \in X$ in concatenation can be written as $h_n \dots h_1 x$.

Although we only take a general algebraic point of view into account, we can still formulate some completely new elementary properties of linguistic hedges ([3,7,8]). Let $h, k \in \mathcal{O}$, h and k are said to be *converse* (or h is said to be converse to k and vice versa) if the statement $\forall x \in X(x \leq hx \text{ iff } x \geq kx)$ holds. And if the statement $\forall x \in X(x \leq hx \text{ iff } x \leq kx)$ holds, then h and k are said to be *compatible*. For any $h, k \in \mathcal{O}$, h is said to be *positive* (or *negative*, resp.) with respect to k if the statement $(x \in X)(\text{either } kx \geq x \text{ implies } h k x \geq kx(h k x \leq kx, \text{ resp.})$ or $kx \leq x \text{ implies } h k x \leq kx(h k x \geq kx, \text{ resp.})$ holds.

Stimulating the semantic properties of terms-sets structure, throughout the paper it will be assumed that

1. Each element $h \in \mathcal{O}$ is an *ordering operation*, i.e. the statement $(\forall x \in X)(\text{either } hx \geq x \text{ or } hx \leq x)$ holds for every h .
2. \mathcal{O} is decomposed into two non-empty subsets \mathcal{O}^+ and \mathcal{O}^- such that for any $h \in \mathcal{O}^+$ and $k \in \mathcal{O}^-$, h and k are *converse*.
3. Let I be the identity of X , i.e. $\forall x \in X, Ix = x$. The sets $\mathcal{O}^+ + I$ and $\mathcal{O}^- + I$ are lattices with unit-elements V and S , respectively, and zero-element I . Because X, \mathcal{O}^+ and \mathcal{O}^- are disjoint there is no confusion to assume for simplicity that the partially ordering relations on each sets X, \mathcal{O}^+ and \mathcal{O}^- will be denoted by the same notation \leq .

As it is discussed in Subsection 2.1, we observe that the partially ordering relations on each sets X , \mathcal{O}^+ and \mathcal{O}^- have a close semantic relationship, which will be formulated in the following definition. In order to simplify notations and formulations, we use from now on superscript c to denote either the superscript $^+$ or $^-$.

Definition 2.1 (Assumption on semantic consistency) *Let $AX = (X, G, \mathcal{O}, \leq)$ be an arbitrary abstract algebra. As it is assumed above, the set \mathcal{O} is decomposed into two disjoint subsets \mathcal{O}^+ and \mathcal{O}^- such that $\mathcal{O}^+ + I$ and $\mathcal{O}^- + I$ are finite lattices with the zero-element I . Then, X and \mathcal{O} are said to be semantically consistent if the following conditions hold:*

1. X is generated from the generators by means of hedges in \mathcal{O} , i.e. elements of X is of the form $h_n \dots h_1 a$, for $h_i \in \mathcal{O}, i = 1, \dots, n$, and $a \in G$.
2. For any $h, k \in \mathcal{O}^c + I, h < k$ in $\mathcal{O}^c + I$ iff $(\forall x \in X)((hx > x \text{ or } kx > x \text{ implies } hx < kx) \text{ and } (hx < x \text{ or } kx < x \text{ implies } hx > kx))$. And, h, k are incomparable in $\mathcal{O}^c + I$ iff $(\forall x \in X)(hx \neq x \text{ or } kx \neq x \text{ implies that } hx \text{ and } kx \text{ are incomparable})$.

Note that 2) in Definition 2.1 describes also an aspect of the universality of hedges!

Example 2.1. Let X be a poset of values of the linguistic variable *Truth* as represented in Figure 1, where $H = \{V, M, A, P, ML, S\}$ is a set of linguistic hedges with V, M, A, P, ML, S standing for Very, More, Approximately, Possibly, More or Less, LeSS (or Little). Intuitively, it can be seen that $H^+ = \{V, M\}$ and $H^- = \{S, A, P, ML\}$, $H^+ + I$ and $H^- + I$ are lattices given in Figure 2. Such an X can be considered as an abstract algebra $AX = (X, G, H, \leq)$, in which $G = \{True, False\}$, \leq on X is the partially ordering relation represented as the graph given in Figure 1 and \leq on $H^c + I$ is given in Figure 2. The result of applying any operation h to an element x can be understood as follows: $hTrue$ and $hFalse$ are defined to be the elements given in Figure 1; and $khx = hx$, for all $h, k \in H$ and $x \in X$. It can easily be seen that X and H are semantically consistent.

2.3 General Construction of Abstract Algebras for Term-Sets.

Let us consider a term-set X_0 and H be the set of all hedges occurring in X_0 . In general, not all terms in X_0 can be written in an expression of the form $h_n \dots h_1 u$ of an abstract algebra considered above, where $h_n, \dots, h_1 \in H$, e.g. the term '*Little App False OR Little Poss False*'. Formally, this term can be rewritten as $Little(App \vee Poss)False$, where \vee is an operation on the set of hedges. The expression $(App \vee Poss)$ can be regarded as a new, artificial hedge and hence this term can be considered as being expressed in the above form. It suggests us to extend the set H into a distributive lattice, denoted by LH , and interpret it as a new set of unary operations. Then, we shall try to show, in the next section, that the abstract algebra

$AX = (X, G, LH, \leq)$ will model the “structure” of X_0 and that ‘*Little App False*’ \cup ‘*Little Poss False*’ = ‘*Little(App \vee Poss)False*’, where \cup is the join operation in the lattice AX .

In this subsection, we shall present how we can construct an abstract algebra for a given term-set formally. Firstly, we construct the lattice LH . We need to recall some notions and notations (see e.g. in [1]).

Definition 2.2 *Let P be a partially ordered set (poset, for short). An element a is said to cover an element b in a poset P , if $a > b$ and there is no $x \in P$ such that $a > x > b$.*

Denote by $l(P)$ the length of a poset P . For a given poset P of finite length with the least element denoted by $\mathbf{0}$, the height of an element $x \in P$ is, by definition, the least upper bound of the length of the chains $\mathbf{0} = x_0 < x_1 < \dots < x_n = x$ between $\mathbf{0}$ and x , and it is denoted by $height(x)$. If P has the greatest element, denoted by $\mathbf{1}$, then clearly $height(\mathbf{1}) = l(P)$. Clearly also that $height(x) = 1$ iff x covers $\mathbf{0}$.

Definition 2.3 *A poset P is said to be graded if there exists a function g from P into the set \mathbb{Z} of all integers with the natural ordering such that :*

- G1. $x > y$ implies $g(x) > g(y)$.
- G2. If x covers y then $g(x) = g(y) + 1$.

Such a function g is called a graded function of P . It is known [1] that any modular lattice of finite length is graded by its height function $height(x)$.

Let L be a modular lattice of finite length, we can define a relation R on L as follows:

$$\forall x, y \in L, (x, y) \in R \text{ iff } height(x) = height(y).$$

It is easily shown that R is an equivalence relation and then we have

$$L = \bigcup_{i=0}^{l(L)} L_i,$$

where $L_i = \{x \in L : height(x) = i\}$, for $i = 0, \dots, l(L)$, are the equivalence classes of the relation R . Clearly, $L_0 = \{\mathbf{0}\}$ and $L_{l(L)} = \{\mathbf{1}\}$, where $\mathbf{0}$ and $\mathbf{1}$ are the zero-element and the unit-element in L , respectively.

Motivated by a practical property of linguistic hedges, we introduce the following condition:

- (C_0) For any $x \in L_i, y \in L_j$ and $i \neq j$, we have either $x > y$ or $x < y$.

As an illustration, the reader can verify that the graded classes of L given in Figure 2 (b) are $L_1 = \{I\}$, $L_2 = \{A, P, ML\}$ and $L_3 = \{S\}$, and the condition (C_0) holds.

It is not difficult to see that the following holds.

Proposition 2.1 *Let L be a modular lattice of finite length satisfying (C_0). Then the following statement holds:*

If $|L_i| > 1$ for an index $i \in \{1, \dots, l(L) - 1\}$ then $|L_{i-1}| = |L_{i+1}| = 1$, where $|A|$ denotes the cardinality of the set A . Moreover, if we denote $e(L_{i+1})$ and $e(L_{i-1})$ the single element of L_{i+1} and L_{i-1} , respectively, then $e(L_{i+1}) = \bigvee_{x \in L_i} x$ and $e(L_{i-1}) = \bigwedge_{x \in L_i} x$, where \bigvee and \bigwedge stand for the join and meet in L , respectively.

Now, let H be a set of linguistic hedges such that $H^+ + I$ and $H^- + I$ are finite lattices.

We will denote by N^+ and N^- the lengths of $H^+ + I$ and $H^- + I$, respectively. Suppose that g^+ and g^- are the graded functions of $H^+ + I$ and $H^- + I$, respectively.

Unless stated otherwise, we shall always adopt in the sequel the assumption that $H^+ + I$ and $H^- + I$ are finite modular lattices satisfying the condition (C_0) . From now on, V and S stand for the unit-operations in $H^+ + I$ and $H^- + I$, respectively. Hence, we have $g^+(V) = N^+$, $g^-(S) = N^-$ and

$$H^+ + I = \bigcup_{i=0}^{N^+} H_i^+, \text{ where } H_i^+ = \{h \in H^+ + I / g^+(h) = i\},$$

$$H^- + I = \bigcup_{i=0}^{N^-} H_i^-, \text{ where } H_i^- = \{h \in H^- + I / g^-(h) = i\}.$$

Now, we are going to construct the lattices, which can be seen as being “freely” generated from $H^+ + I$ and $H^- + I$ as follows.

Let us consider $H^+ + I$. Assume that for some index $i \in \{1, \dots, N^+\}$, $|H_i^+| > 1$ and $H_i^+ = \{h_1^i, \dots, h_n^i\}$. By Proposition 2.1, the sets $H_{i+1}^+ = \{h^{i+1}\}$ and $H_{i-1}^+ = \{h^{i-1}\}$ are single-element sets. For such an i , the ordering relationships between the elements of H_{i-1}^+ , H_i^+ , H_{i+1}^+ can be expressed as Figure 3. Note that there exists a natural ordering relation between graded classes H_i^+ : $H_i^+ < H_j^+$ iff $i < j$; where $H_i^+ < H_j^+$ means that $h < k$ for every $h \in H_i^+$ and $k \in H_j^+$.

By $LH_i^+ = (L(H_i^+), \bigvee, \bigwedge)$ we denote the free distributive lattice³ generated from the incomparable elements h_1^i, \dots, h_n^i of H_i^+ . Particularly, for an index i such that $|H_i^+| = 1$ we have $LH_i^+ = H_i^+$. Put $LH^+ = \bigcup_{i=1}^{N^+} LH_i^+$ and $LH^+ + I = LH^+ \cup \{I\} = \bigcup_{i=0}^{N^+} LH_i^+$. Then, $LH^+ + I$ becomes a distributive lattice under the ordering relation induced by the ordering relations on the lattices LH_i^+ and the one defined between classes LH_i^+ (that is we have $LH_i^+ \leq LH_j^+$, for any i, j such that $i \leq j$). The classes LH_i^+ are called also graded classes of LH^+ , for convenience. Figure 4 shows a picture of a segment of the lattice $LH^+ + I$, where $|H_i^+| > 1$.

By an analogous way, we can construct the lattice $LH^- + I$ generated from $H^- + I$. Here, there is no confusion, because H^+ and H^- are assumed to be disjoint and hence, so are LH^+ and LH^- , where $LH^+ = LH^+ + I \setminus \{I\}$ and $LH^- = LH^- + I \setminus \{I\}$. Thus, we have the following

Proposition 2.2 *($LH^+ + I, \bigwedge, \bigvee, I, V, \leq$) and ($LH^- + I, \bigwedge, \bigvee, I, S, \leq$) are finite distributive lattices with the unit-elements V and S , respectively, and the zero-element I .*

³⁾ see G. Birkhoff [1]

Example 2.2. Let us consider a set of hedges as in Example 2.1. Clearly, $H^+ + I$ and $H^- + I$ are finite modular lattices and satisfy condition (C_0) . By the way of constructing as above, the obtained distributive lattices $LH^+ + I$ and $LH^- + I$ generated from $H^+ + I$ and $H^- + I$, respectively, can be represented as in Figure 5.

Now, let us turn back to the previous consideration of the given term-set X_0 and the set H of hedges. Regard H as a set of unary operations and construct the lattice LH as above. Let $AX = (X, G, LH, \leq)$ be an abstract algebra satisfying the following conditions: (i) G is the set of the primary terms occurring in X_0 and the additional special constants $\mathbf{0}$, \mathbf{W} and $\mathbf{1}$; (ii) $X = LH(G)$; (iii) \leq is a partially ordering relation on X such that X and LH are semantically consistent. We treat it as an abstract algebra for the term set X_0 .

Obviously, it is easy to find an abstract algebra AX fulfilling (i) and (ii). By Proposition 3.5 in Section 3, there exists a partially ordering relation \leq on X such that (iii) satisfied. Therefore, given X_0 we can always define a corresponding abstract algebra AX for X_0 . The sets X and X_0 are not identical, e.g. the composed term containing connectives *AND*, *OR*, *NOT* in X_0 like ‘*Little App False OR Little Poss False*’ do not occur in X . However, it will be shown in Section 3 and 4 that they are very similar.

From now on we always denote H the set of primary hedges and LH the lattice of composed hedges constructed as above. However, the elements in H or LH are called simply hedges.

3 AN AXIOMATIZATION OF RH_ALGEBRAS AND THEIR PROPERTIES.

3.1 An Axiomatization of RH_algebras and Basic Properties.

First of all we introduce the following notion.

Definition 3.1 Let $AX = (X, G, LH, \leq)$ be an arbitrary abstract algebra and V be the unit operation in $LH^+ + I$. The set H is said to have PN-homogeneous property, where PN is an abbreviation of Positive and Negative, provided that for any graded class H_i^c , if V is positive (or negative, resp.) w.r.t. a certain operation h in H_i^c , then V is also positive (or negative, resp.) w.r.t. any other ones in H_i^c .

For example, it can be verified that the set H in Example 2.1 satisfies the *PN-homogeneous property*. This property says that the elements in every H_i^c have the same positive or negative property. That is it describes the homogeneity of the graded classes H_i^c . In the end of Section 3 we shall give some statements which explain more details the homogeneity of H_i^c . However, if we add in Example 2.1 a new hedge “*Notso*” denoted by N , whose meaning can be determined by the term “*not*” in the sentence “*He is not very tall*”. It means that “*He is certainly tall but not so very tall*”. Thus, “*Notso*” is a “local” negation and by its meaning we have $N \in H^-$ and V is positive w.r.t. N . Hence, the set $L_2 = \{A, P, ML, N\}$ is not PN-homogeneous. So, PN-homogeneity is a hypothesis and hence it is a limitation of the paper.

Suppose that $LH^+ + I$ and $LH^- + I$ are distributive lattices, which are generated from $H^+ + I$ and $H^- + I$, respectively, as presented in the previous section.

Let $I^+ = \{0, 1, \dots, N^+\}$, $I^- = \{0, 1, \dots, N^-\}$ and $SI^+ = \{i \in I^+ : |H_i^+| > 1\}$, $SI^- = \{i \in I^- : |H_i^-| > 1\}$. That is the set SI^c consists of the indexes i which are not *single-element* classes.

Recall that by c we mean either $^+$ or $^-$. For instance, given the term “ LH_i^c for some $i \in SI^c$ ”, the statement presents two instances to be obtained by substituting c in turn by $^+$ and $^-$. Here is an example of a statement formulated with this convention: for any $i \in SI^c$, LH_i^c is the free distributive lattice generated by the incomparable elements of H_i^c and is a sublattice of $LH^c + I$; and for any $i \in I^c \setminus SI^c$, LH_i^c is a single-element set, i.e. $LH_i^c = H_i^c$, and we have $LH^c = \bigcup_{i=1}^{N^c} LH_i^c$.

Let us denote by UOS (Unit Operations Set) the set of two unit-elements V and S of $LH^+ + I$ and $LH^- + I$, respectively. Further, denote by Nat the set of all non-negative integers.

Set $LH = LH^+ \cup LH^-$ and $LH + I = LH^+ \cup LH^- \cup \{I\}$.

Consider an algebra $AX = (X, G, LH, \leq)$, where G is a set of constants or zero-argument operations, LH is a set of one-argument operations.

For every $x \in X$, $LH(x)$ denotes the set of all elements generated from x by means of operations in LH , i.e. that elements of $LH(x)$ are of the form $h_n \dots h_1 x$, where $h_i \in LH, i = 1, \dots, n$. More generally, for any $Y \subset X$ and $H' \subset LH$, $H'(Y)$ denotes the subset of X generated from the elements in Y by means of the operations in H' . As usual, LH^* denotes the set of all strings of hedges in LH . However, by $H'[Y]$ we denote the set $\{hx : h \in H' \text{ and } x \in Y\}$.

Remark 3.1 (a) From the way the lattices $LH^+ + I$ and $LH^- + I$ have been constructed, it can be seen that lattices $LH^+ + I$ and $LH^- + I$ also satisfy condition (C_0) , in which the notations L_i and L_j are replaced with LH_i^c and LH_j^c , respectively.

(b) For easily understanding the axiomatization, we give the following intuitive explanation. Given a term x . According to the above notations, we have

$$LH_i^c[x] = \{hx : h \in LH_i^c\} \text{ and } LH(LH_i^c[x]) = \bigcup_{u \in LH_i^c[x]} LH(u) = \bigcup_{h \in LH_i^c} LH(hx).$$

Clearly,

$$LH(x) = \{x\} \cup \bigcup_{c \in \{+, -\}} \{LH(LH_i^c[x]) : i = 1, \dots, N^c\}.$$

The set $LH(x)$ is called the term-set of x and the sets $LH(LH_i^c[x])$ are called *the graded term-sets* of x , because they are related to the graded class H_i .

Analysing intuitive semantic properties of hedges, we can observe that Condition (C_0) will induce a linearly ordering relation between the graded term-sets of x , for any x . For illustration, let us consider $x = True$ and

the graded classes, $\{S\}$, $\{A, P, ML\}$, $\{I\}$, $\{M\}$ and $\{V\}$, given in Figure 2. Intuitively, we have the following ordering between the graded term-sets:

$$LH(LessTrue) < LH(L(App, Poss, M.orLess)[True]) < True < LH(MoreTrue) < LH(VeryTrue),$$

where $L(App, Poss, M.orLess)$ denotes the lattice generated from generators $App, Poss$ and $M.orLess$.

Now, we are ready to introduce an axiomatization that refines the structure of hedge algebras.

In [3] and [9], a system of axioms for hedge algebras and extended hedge algebras was introduced. In [6] refined hedge algebras were defined by the assumption that they firstly are hedge algebras and, secondly, must fulfil certain additional axioms.

In this paper, we establish a unified theory by introducing a unified system of axioms. It defines a class of algebras called also refined hedge algebras.

Definition 3.2 *An algebra $AX = (X, G, LH, \leq)$ is said to be a refined hedge algebra (abbr. RH-algebra), if X and LH are semantically consistent (Def.2.1) and the following conditions hold (where $h, k \in LH$):*

- (A1) *Every operation in LH^+ is converse to each operation in LH^- .*
- (A2) *The unit operation V of $H^+ + I$ is either positive or negative w.r.t. any operation in H . In addition, H should satisfy the PN-homogeneous property.*
- (A3) (Separateness or semantic heredity of independent terms) *If u and v are independent, i.e. $u \notin LH(v)$ and $v \notin LH(u)$, then $x \notin LH(v)$ for any $x \in LH(u)$ and vice-versa. If $x \neq hx$ then $x \notin LH(hx)$. Further, if $hx \neq kx$ then hx and kx are independent.*
- (A4) (Semantic heredity: preserving comparability and incomparability of terms) *If hx and kx are incomparable, then so are any elements $u \in LH(hx)$ and $v \in LH(kx)$. Especially, if $a, b \in G$ and $a < b$ then $LH(a) < LH(b)$. And if $hx < kx$ then*
 - (i) *In the case that $h, k \in LH_i^c$, for some $i \in SI^c$, the following statements hold:*
 - $\delta hx < \delta kx$, for any $\delta \in LH^*$.
 - δhx and y are incomparable, for any $y \in LH(kx)$ such that $y \not\geq \delta kx$.
 - δkx and z are incomparable, for any $z \in LH(hx)$ such that $z \not\leq \delta hx$.
 - (ii) *If $\{h, k\} \not\subseteq LH_i^c$ for every $i \in SI^c$ or $hx = kx$, then $h'hx \leq k'kx$, for any $h', k' \in UOS$.*
- (A5) (Linear ordering between graded term-sets) *Let us consider $u \in LH(x)$ and suppose that $u \notin LH(LH_i^c[x]) = \bigcup_{h \in LH_i^c} LH(hx)$, for some $i \in I^c$. If there exists $v \in LH(hx)$, for some $h \in LH_i^c$ such that $u \geq v$ (or $u \leq v$), then $u \geq h'v$ (or $u \leq h'v$, respectively), for any $h' \in UOS$.*

By comparing the two definitions, one for RH_algebras as defined above and the other for hedge algebras as defined in [8, Definition 3], it can easily be seen that any hedge algebra can be embedded into an appropriate RH_algebra as its sub-poset. In the other words, RH_algebra is an extension of hedge algebra.

Example 3.1. (a) Let us consider an algebraic structure $AX = (X_1, G, LH, \leq)$, where, as considered in Example 2.1 previously, H is the set $\{V, M, S, A, P, ML\}$, $G = \{True, False\}$, but X is the set consisting of the elements $X_1 = \{ha : h \in LH + I, a \in G\}$, which are ordered as represented in Figure 6 (a). Recall that $L(A, P, ML)$ denotes the lattice generated from the incomparable A, P and ML and $L(A, P, ML)[a]$ denotes the set $\{ha : h \in L(A, P, ML)\}$. Here, hx is defined as follows: for every hedge operation h in LH , $hTrue$ and $hFalse$ are defined as the elements given in Figure 6(a); for $x \neq True$ and $x \neq False$, we define $hx = x$. It can easily be seen that the operations are well defined and AX satisfies the axioms in Definition 3.2.

(b) Consider an algebraic structure $AX_2 = (X_2, G, LH, \leq)$, where G, LH are the same as given in (a) and $X_2 = X_1 \cup \{kha : h, k \in LH, a \in G\}$. The operations of AX_2 are defined as follows: a, ha and kha , for any a, h and k , are defined to be different each from other. And in addition, for any $x = kha, k' \in LH$ and $a \in G$ it is assumed that $k'x = x$. The elements in X_2 will be ordered in the following way. The ordering relation \leq_1 on X_1 is defined the same as in the case (a). Now, we extend the relation \leq_1 to X_2 step by step. It can be seen that V (and hence all operation in $LH^+ = H^+$) is positive w.r.t. V, M, S and negative w.r.t. A, P, ML ; S (and hence all operation in LH^-) is positive w.r.t. A, P, ML and negative w.r.t. V, M and S .

(i) For each $h \in LH$, the relation \leq on $X_2(h) = \{kha : h, k \in LH, a \in G\}$ is defined as follows. For $\{k, k'\} \not\subset LH^c$, i.e. k and k' are converse, then kha and $k'ha$ are defined to be comparable and the ordering relationship between these elements is determined based on the fact that k (or k') is positive or negative w.r.t. h . For the case $k < k'$ (and hence $\{k, k'\} \subset LH^c$ for some c), if k is positive w.r.t. h then we define $ha < kha < k'ha$ whenever $a < ha$ and $ha > kha > k'ha$ whenever $a > ha$, and if k is negative w.r.t. h then we define $ha < kha < k'ha < a$ whenever $a > ha$ and $ha > kha > k'ha > a$ whenever $a < ha$.

(ii) For any h and h' with $h \neq h'$, the ordering relationships between $X_2(h)$ and $X_2(h')$ will be established as follows: If $ha < h'a$ then for all $h \in LH$ we define $kha < kh'a$. The extension of \leq_1 to X_2 defined by (i) and (ii) is denoted by \leq .

(iii) Taking the reflexive and transitive closure of \leq , we obtain the required ordering relation \leq_2 .

Two elements x and y in X_2 are comparable if and only if it can be defined only by either (i), (ii) or (iii). Otherwise, they are incomparable. For example, if k and k' are incomparable, then it follows that kha and $k'ha$ are incomparable; or if ha and $h'a$ are incomparable, then for any $k, k' \in LH$ we infer that kha and $k'h'a$ to be incomparable. For additional example, suppose that $ha < h'a$, $h, h' \in LH_i^c$ and $ha < kha < k'ha$. Then, it can be seen that $kha < kh'a$, but the pair of elements kha and $h'a$ as well as the one of $k'ha$ and kha are

incomparable.

For illustration, we represent a segment of the poset X_2 in Figure 6 (b). It can be verified that AX_2 is well defined and fulfils all axioms in Definition 3.2.

For the sake of convenience, we recall some notions given in [8].

Definition 3.3 For any $h, k \in LH$, we shall write $hx \leq kx$ ($hx \leq Ix$) if for any h', k' in UOS and any $m, n \in Nat$, $V^n h' hx \leq V^m k' kx$ ($V^n h' hx \leq Ix$). In the case that the last inequalities are always strict, then we shall write $hx \ll kx$ ($hx \ll Ix$).

As an example, the inequalities $V^n \text{VeryMoreTrue} \leq V^m \text{LittleVeryTrue}$, for all n and m , are accepted intuitively, and so we can write $\text{MoreTrue} \ll \text{VeryTrue}$.

Definition 3.4 Let x and u be two elements of an RH-algebra $AX = (X, G, LH, \leq)$. The expression $h_n \dots h_1 u$ is said to be a canonical representation of x w.r.t. u in AX if (i) $x = h_n \dots h_1 u$ and (ii) $h_i \dots h_1 u \neq h_{i-1} \dots h_1 u$ for every $i \leq n$.

The easy proofs of all results presented in the rest of the section can be found in [7] with almost unchanged.

Theorem 3.1 Let $AX = (X, G, LH, \leq)$ be an RH-algebra. Then, the following statements hold.

- (i) If $hx \leq kx$ then $hx \leq kx$.
- (ii) The operations in LH^c are compatible .
- (iii) If $x \in X$ is a fixed point of an operation h in LH , i.e. $hx = x$, then it is also a fixed point of any other k in LH .
- (iv) If $x = h_n \dots h_1 u$, then there exists an index i such that the suffix $h_i \dots h_1 u$ of x is a canonical representation of x w.r.t. u and $h_j x = x$, for all $j > i$.
- (v) If $h \neq k$ and $hx = kx$ then x is a fixed point.
- (vi) For any $h, k \in LH$, if $x \leq hx$ ($x \geq hx$) then $Ix \ll hx$ ($Ix \gg hx$) and if $hx \leq kx$, $h \neq k$ and $\{h, k\} \not\subset LH_i^c$ for every $i \in SI^c$, then $hx \ll kx$.

Because of statement (iii) of Theorem 3.1, we can use terminology “a fixed point” instead of “a fixed point of an operation”. In addition, although statement (iii) is simple but it describes an interesting intuitive property of linguistic meaning: if $hx = x$, i.e. no proper new meaning can be generated from x by means of a hedge h , then also no new meaning can be deduced from x by means of any other hedge k . It seems to be appropriate to the intuition!

Theorem 3.2 For any $h \in LH$, there exist two unit operations h^- and h^+ such that h^- is negative and h^+ is positive w.r.t. h and for any $h_1, \dots, h_n \in LH, x \in X$,

$$V^n h^- h x \leq h_n \dots h_1 h x \leq V^n h^+ h x, \text{ if } h x \geq x, \text{ and } V^n h^- h x \geq h_n \dots h_1 h x \geq V^n h^+ h x, \text{ if } h x \leq x.$$

Corollary 3.1 (i) Suppose that $h x < k x$. If $\{h, k\} \not\subset LH_i^c$ for every $i \in SI^c$, then for any two strings of hedges δ and δ' , the inequality $\delta h x < \delta' k x$ holds.

(ii) Let u be an arbitrary element in X and $x \in LH(u)$. Then, there exist always elements $y, z \in UOS(u)$, i.e. z and y are generated from u by means of the unit operations, such that $y \geq x \geq z$. Furthermore, either one of the equalities $u \leq x \leq V^n h u$ and $u \geq x \geq V^n h u$ holds, for a suitably chosen $h \in LH$ and for a sufficiently great number $n \in Nat$.

3.2 Criteria for Determining the Comparability of Elements

It will be seen that the ordering of X is some what similar to the alphabetical one. The following theorem establish criteria for determining the ordering relationship between elements of an RH-algebra. Here, the notation $x_{<j}$ is defined as follows: if $x = h_n \dots h_1 u$, then $x_{<j}$ denotes the expression $h_{j-1} \dots h_1 u$, for $1 \leq j \leq n + 1$, with a convention that $x_{<1} = u$.

Theorem 3.3 Let $x = h_n \dots h_1 u$ and $y = k_m \dots k_1 u$ be two arbitrary canonical representations of x and y w.r.t. u , respectively. Then

1. $x = y$ iff $m = n$ and $h_j = k_j$ for all $j \leq n$.
2. If $x \neq y$ then there exists an index $j \leq \min\{m, n\} + 1$ (here as a convention it is understood that if $j = \min\{m, n\} + 1$, then either $h_j = I$ for $j = n + 1 \leq m$ or $k_j = I$ for $j = m + 1 \leq n$) such that $h_{j'} = k_{j'}$, for all $j' < j$ and

(a) $x < y$ iff one of the following conditions holds

- $h_j x_{<j} < k_j x_{<j}$ and $\delta k_j x_{<j} \leq \delta' k_j x_{<j}$ or $\delta h_j x_{<j} \leq \delta' h_j x_{<j}$, if $h_j, k_j \in LH_i^c$ for some $i \in SI^c$ (and hence $h_j \neq I$ and $k_j \neq I$), where $\delta = h_n \dots h_{j+1}, \delta' = k_m \dots k_{j+1}$.
- $h_j x_{<j} < k_j x_{<j}$, if otherwise (i.e. either $j \leq \min\{m, n\}$ and, for every $i \in SI^c, \{h_j, k_j\} \not\subset LH_i^c$ or $j = \min\{m, n\} + 1$ and one of h_j, k_j is the identity I).

(b) x and y are incomparable iff there exists $i \in SI^c$ such that both h_j and k_j together belong to LH_i^c and one of the following conditions holds

- $h_j x_{<j}$ and $k_j x_{<j}$ are incomparable,

- $h_j x_{<j} < k_j x_{<j}$ and $\delta k_j x_{<j} \not\leq \delta' k_j x_{<j}$,
- $h_j x_{<j} > k_j x_{<j}$ and $\delta' h_j x_{<j} \not\leq \delta h_j x_{<j}$.

Remark 3.2. 1) At first glance, one may think that the theorem is meaningless, because it leads from the comparison of two elements to the comparison of two other elements: The comparison between $x = \delta h_j x_{<j}$ and $y = \delta' k_j x_{<j}$ is moved to that between $x' = \delta k_j x_{<j}$ and $y' = \delta' k_j x_{<j}$ or between $x' = \delta h_j x_{<j}$ and $y' = \delta' h_j x_{<j}$. But, notice that the length of the common suffix of x' and y' is greater than that of x and y . It leads to a procedure by which in a finite number of steps one can decide whether the given elements x and y are comparable and which one is greater than the other.

2) If x is not a fixed point and u is an arbitrary element in X , then the canonical representation of x w.r.t. u is unique, if it exists.

The proofs of Propositions 3.1-3.4 below will be omitted. Their similar proofs can be referred to [7].

Proposition 3.1 *For any $x \in X$ and $i \in SI^c$. If there exists a hedge $h \in LH_i^c$ such that hx is a fixed point, then so is kx , for any $k \in LH_i^c$.*

As a consequence of Proposition 3.1 and (A4), we have the following.

Proposition 3.2 *For any $x \in X$ and $h, k \in LH_i^c$, for some $i \in SI^c$ and for any $\delta \in LH^*$, $\delta h x$ is a fixed point iff $\delta k x$ is a fixed point.*

Recall that the RH_algebra is constructed from a given PN-homogeneous hedge algebra. Naturally, one may ask whether the PN-homogeneous property of $LH^+ + I$ (but not of $H^+ + I$) still holds if we replace H_i^c with LH_i^c in Definition 3.1. The following proposition gives the answer to this question.

Proposition 3.3 *If the unit operation V in $LH^c + I$ is positive (negative, resp.) w.r.t. a certain h in H_i^c , for some $i \in SI^c$, then V is also positive (negative, resp.) w.r.t. any operations in LH_i^c .*

Proposition 3.4 *For any $h, k \in LH_i^c$, with $i \in SI^c$, and for any $x \in X$. The following statements hold:*

- (i) $\delta h x > x$ ($\delta h x < x$) iff $\delta k x > x$ ($\delta k x < x$), for any $\delta \in LH^*$.
- (ii) If $hx \neq kx$, then $\delta h x$ and $\delta' h x$ are incomparable iff $\delta k x$ and $\delta' k x$ are incomparable, for any $\delta, \delta' \in LH^*$.
- (iii) $\delta h x > \delta' h x$ iff $\delta k x > \delta' k x$, for any $\delta, \delta' \in LH^*$.

Proposition 3.5 *Let us consider an abstract algebra $AX = (X, G, LH)$, where $X = \{\sigma c : c \in \{a^+, a^-\}, |\sigma| \leq p\} \cup \{\mathbf{1}, \mathbf{W}, \mathbf{0}\}$, p is a positive integer, $G = \{\mathbf{1}, a^+, \mathbf{W}, a^-, \mathbf{0}\}$ with $\mathbf{1} > a^+ > \mathbf{W} > a^- > \mathbf{0}$, and LH is the set of unary operations constructed as in Section 2. Let m_{PN} is an arbitrary mapping $m_{PN} : LH \rightarrow \{+, -\}$ (it means that if $m_{PN}(h) = +$ or $m_{PN}(h) = -$, then V (and hence all operations in LH^+) is positive or negative w.r.t. h , respectively), which satisfies Proposition 3.3, i.e. m_{PN} restricted on each graded class of LH*

is constant. Then there exists a semantically ordering relation \leq over X such that X and LH are semantically consistent.

Proof. Based on Theorem 3.3, we shall construct step by step a semantically ordering relation \leq over X . Note that $X = X^+ \cup X^- \cup \{\mathbf{1}, \mathbf{W}, \mathbf{0}\}$, where $X^+ = \{\sigma a^+ : |\sigma| \leq p\}$ and $X^- = \{\sigma a^- : |\sigma| \leq p\}$.

(1) For every $x = \sigma a^+ \in X^+$, set $\mathcal{S}(x) = \{\sigma' a^+ : \sigma' \text{ is a suffix of } \sigma, \text{ i.e. } \sigma = \sigma'' \sigma'\}$. On $\mathcal{S}(x)$ we introduce a semantically ordering relation $(\mathcal{S}(x), \leq)$ defined recursively as follows:

For $|u| = 2$, i.e. $u = \sigma' a^+ = h a^+ \in \mathcal{S}(x)$, we define $h a^+ > a^+$ if $h \in LH^+$ and $h a^+ < a^+$ if $h \in LH^-$. Now suppose that the ordering relation between hu and u has been defined for all $z = hu \in \mathcal{S}(x)$ such that $|hu| < j \leq p$. Consider element $z' = k h u \in \mathcal{S}(x)$. In the case $m_{PN}(h) = +$, for $k \in LH^+$ (intuitively, it means k is positive w.r.t. h), we define $v < k h u < hu$ if $v < hu < u$ and $v > k h u > hu$ if $v > hu > u$, where $v \in \mathcal{S}(x)$ and $|v| < j$; for $k \in LH^-$ (intuitively, it means that k is negative w.r.t. h), we define $u < k h u < hu$ if $u < hu$ and $u > k h u > hu$ if $u > hu$; In the case $m_{PN}(h) = -$, for $k \in LH^-$ (intuitively, it means k is positive w.r.t. h), we define $v < k h u < hu$ if $v < hu < u$, and $v > k h u > hu$ if $v > hu > u$, where $v \in \mathcal{S}(x)$ and $|v| < j$; for $k \in LH^+$ (intuitively, it means that k is negative w.r.t. h), we define $u < k h u < hu$ if $u < hu$ and $u > k h u > hu$ if $u > hu$.

It can be verified that $(\mathcal{S}(x), \leq)$ is linearly ordered, for every $x \in X^+$. Clearly, $X^+ = \cup\{\mathcal{S}(x) : x \in X^+ \text{ and } |x| = p + 1\}$ and it is easily seen that the defined in such a way ordering relations on $\mathcal{S}(x)$ and $\mathcal{S}(y)$ are consistent, that is they are identical on $\mathcal{S}(x) \cap \mathcal{S}(y)$.

(2) Now let us consider two arbitrary elements $x, y \in X^+$ and suppose that $x = \sigma h u$ and $y = \tau k u$, where $h \neq I$ and $k \neq I$ and u is a maximal common suffix of x and y , and hence $h \neq k$. Obviously, for all $u \in X^+$, $\{x, y\} \not\subset \mathcal{S}(u)$, i.e. we have not defined an ordering relationship between x and y , yet. Now, we define it by induction on $|u|$.

For $|u| = p$, we have $\sigma = \tau = \epsilon$ (the empty string) and $x = hu$ and $y = ku$. If $\{h, k\} \not\subset LH^c$ for any superscript c , i.e. h and k are converse, then x, y must be defined to be comparable and the ordering relationship between x and y is induced by the ordering relationships between hu and u and between ku and u , which have been defined in (1) already. If $\{h, k\} \subset LH^c$ for a suitable superscript c , then there are two possibilities. The first one: h and k are comparable, say, $h < k$. In the case that $u < hu$, we define $hu < ku$, and in the case $u > hu$, we define $hu > ku$. The second one: h, k are incomparable. In this case we define hu and ku to be incomparable.

Suppose that the ordering relationships between two elements x and y have been defined for any x and y , whose maximal common suffix u satisfying $|u| > j$. Consider two arbitrary elements $x' = \sigma' h u'$ and $y' = \tau' k u'$ such that $|u'| = j$.

If $\{h, k\} \not\subset LH^c$ then $\sigma'hu'$ and $\tau'ku'$ are comparable and the ordering relationship between x' and y' is defined similarly as in the corresponding case above. Suppose that $\{h, k\} \subset LH^c$ and, furthermore, h and k are comparable, say, $h < k$. If h and k belong to two different graded classes LH_i^c and LH_j^c of LH^c , then we define $\sigma'hu' < \tau'ku'$ whenever $ku' > u'$ (note that this inequality has been defined already), and $\sigma'hu' > \tau'ku'$ whenever $ku' < u'$. Now let h, k belong together to a certain graded class. For σ', τ' such that $\sigma' = \tau'$ we define $\sigma'hu' < \tau'ku'$ if $u' < ku'$, and $\sigma'hu' > \tau'ku'$ if $u' > ku'$. For σ', τ' such that $\sigma' \neq \tau'$ we define $x < y$ if it can be found that either $hu' < ku'$ and $\sigma'ku' < \tau'ku'$ together hold or $hu' < ku'$ and $\sigma'hu' < \tau'hu'$ together hold; and similarly we define $x > y$ if it can be found that either $hu' > ku'$ and $\sigma'ku' > \tau'ku'$ hold or $hu' > ku'$ and $\sigma'hu' > \tau'hu'$ hold. Note that the comparability of hu' and ku' (with $\sigma' = \tau' = \epsilon$) and the ordering relationships between $\sigma'hu'$ and $\tau'hu'$ and between $\sigma'ku'$ and $\tau'ku'$ have been defined already, since $|hu'| = |ku'| = j + 1 > j$.

(3) It can easily be verified that the just constructed ordering relation is antisymmetric. Therefore, the desired semantically ordering relation on X^+ is obtained by taking its reflexive and transitive closure and denoted also by \leq . By an analogous way, we can define the semantically ordering relation on $X^- = \{\sigma a^- : |\sigma| \leq p\}$.

The desired semantically ordering relation on X is now induced by those have been defined on X^+ and X^- and by the inequalities $\mathbf{1} > X^+ > \mathbf{W} > X^- > \mathbf{0}$.

Now, we can verify that LH and X are semantically consistent. Indeed, suppose that $h < k$, and so $\{h, k\} \subset LH^c$ for a suitable c . It can be deduced from the above construction of \leq on X , that for all $x \in X^+$ we always have $hx \leq kx$ if $x \leq kx$ and $hx \geq kx$ if $x \geq kx$. On the other hand, if h and k are incomparable, then so are hx and kx , whenever $kx \neq x$, (by Step (1) and (2) above).

4 LATTICE STRUCTURE OF RH_ALGEBRAS.

In this section, we shall study some main properties of RH_algebras. It will be shown that RH_algebra is a distributive lattice if the set of the primary generators is a chain. Before proving distributivity of RH_algebras, we show first that every RH_algebra with a chain of the primary generators is a lattice and, moreover, we give a recursive formula for computing the meet and the join of any two elements of the algebra.

Theorem 4.1 *Let $AX = (X, G, LH, \leq)$ be an RH_algebra and G be a chain of generators. Then AX is a lattice. Moreover, if x and y are incomparable, then they can be represented in the form $x = \delta hw$ and $y = \gamma kw$, where $h, k \in LH_i^c$, for some $i \in SI^c$, and $\delta, \gamma \in LH^*$, and we have*

$$x \cup y (= \delta hw \cup \gamma kw) = \delta w' \cup \gamma w' \quad \text{and} \quad x \cap y (= \delta hw \cap \gamma kw) = \delta z' \cap \gamma z',$$

where $w' = (h \vee k)w$ and $z' = (h \wedge k)w$ if $hw > w$; $w' = (h \wedge k)w$ and $z' = (h \vee k)w$ if $hw < w$ and \cup, \cap stand for join, meet in AX , while \vee, \wedge stand for join and meet in $LH^c + I$.

Proof. See Appendix A.

For any $x \in X$, let us denote $LH[x] = \{hx : h \in LH + I\}$. As a consequence of Theorem 2.1 and Theorem 4.1, it follows directly the following.

Corollary 4.1 *Let $AX = (X, G, LH, \leq)$ be an RH-algebra and G is a chain. The following statements hold:*

(i) $LH(x)$ is a sublattice of AX .

(ii) $LH[x]$ is a distributive sublattice of AX . Furthermore, for any $x \in X$ and for any two compatible hedges h and k in LH , we have

$$hx \cup kx = \begin{cases} (h \vee k)x & \text{if } hx \geq x, \\ (h \wedge k)x, & \text{if } hx \leq x, \end{cases} \quad \text{and} \quad hx \cap kx = \begin{cases} (h \wedge k)x & \text{if } hx \geq x, \\ (h \vee k)x, & \text{if } hx \leq x. \end{cases}$$

Proposition 4.1 *Let $AX = (X, G, LH, \leq)$ be an RH-algebra and G is a chain. Then, for any $h, k \in LH_i^c$, where $i \in SI^c$, and for any $x \in X$ such that $hx \neq kx$, there exists a lattice isomorphism f from $LH(hx)$ onto $LH(kx)$ defined as follows: $f(\delta hx) = \delta kx$.*

Proof. By Proposition 3.4.

Before proving the distributive property of RH-algebra, it may be useful to recall the following characterization of distributivity for lattices.

Theorem 4.2 [2] *Let L be a lattice. Then L is a non-distributive lattice iff M_5 or N_5 can be embedded into L as its sublattices, where M_5 or N_5 are two five-element lattices depicted in Figure 7.*

We now prove the distributivity of RH-algebras with a chain of the primary generators.

Theorem 4.3 *Let $AX = (X, G, LH, \leq)$ be an RH-algebra. If G is a chain then the lattice AX is distributive.*

Proof. See Appendix B.

5 SYMMETRICAL RH-ALGEBRAS.

In natural languages there are many linguistic variables, which have only two distinct primary terms. These terms have intuitive contradictory meaning such as ‘true’ and ‘false’, ‘old’ and ‘young’, ‘large’ and ‘small’, ‘tall’ and ‘short’, etc. This suggested the authors of [9] to investigate extended hedge algebras with exactly two primary generators, one of which is called positive generator, denoted by t , and the other is called negative generator, denoted by f . The positive and negative generators are characterised by $Vt \geq t, Vf \leq f$ and $t > f$. Under such a normalization, it seems reasonable to consider ‘true’, ‘old’, ‘large’ and ‘tall’ as positive generators and ‘false’, ‘young’, ‘small’ and ‘short’ as negative ones. Therefore, in this section we shall examine RH-algebras $AX = (X, G, LH, \leq)$ with exactly one positive t , one negative f , the special constants $\mathbf{0}, \mathbf{1}$ and the neutral \mathbf{W} , i.e. $G = \{\mathbf{1}, t, \mathbf{W}, f, \mathbf{0}\}$.

For every x in X , we now define a so-called contradictory element of x as follows.

Assume that $x = h_n \dots h_1 a$, where $a \in \{t, f\}$, is a representation of x with respect to a . An element y is said to be a contradictory element of x if it can be represented as $h_n \dots h_1 a'$, with $a' \in \{t, f\}$ and $a' \neq a$. The contradictory element of $\mathbf{1}$ is $\mathbf{0}$ and, conversely, the contradictory element of $\mathbf{0}$ is $\mathbf{1}$. In the case where $x = \mathbf{W}$, we define contradictory element of \mathbf{W} to be just itself. For example, $y = \text{'very very false'}$ is a contradictory element of $x = \text{'very very true'}$; $v = \text{'very little bad'}$ is a contradictory element of $u = \text{'very little good'}$. By the definition, it is obvious that the positive generator is a contradictory element of the negative one and vice-versa and if y is a contradictory element of x then x is a contradictory element of y .

Definition 5.1 An RH-algebra $AX = (X, G, LH, \leq)$, where G is defined as above, is said to be a symmetrical RH-algebra provided every element x in X has a unique contradictory element in X , denoted by x^- .

We now give a characterization of symmetrical RH-algebras.

Theorem 5.1 An RH-algebra $AX = (X, G, LH, \leq)$ is symmetrical iff AX satisfies the following condition:

(SYM) For every element $x \in X$, x is a fixed point iff x^- is a fixed point.

Proof. To prove the necessity, assume the contrary that x is a fixed point and $x^- \neq hx^-$, for some $h \in LH$. By definition, $(x^-)^- = x$ and the contradictory element of $u = hx^-$ is the element $u^- = hx = x$. This shows that u and x^- are two distinct contradictory elements of x , a contradiction to the definition of symmetrical RH-algebras.

To prove the sufficiency, we assume that AX satisfies the condition (SYM). By the definition of the contradictory elements, each element $\mathbf{1}$ and $\mathbf{0}$ has, evidently, a unique contradictory element. Now, let us consider an arbitrary element $x \in X \setminus \{\mathbf{1}, \mathbf{W}, \mathbf{0}\}$ and let u and v be contradictory elements of x .

Suppose that u and v are expressed in the form $u = h_n \dots h_1 c^-$ and $v = k_m \dots k_1 c^-$, which are defined based on two given representations $h_n \dots h_1 c$ and $k_m \dots k_1 c$ of x , where $c, c^- \in \{t, f\}$ and $c \neq c^-$. It is known that there exists an index $i \leq \min\{n, m\}$ such that $h_i \dots h_1 c$ is the canonical representation of x w.r.t. c . This implies that $h_j = k_j$ for all $j \leq i$. It is clear that if $m = n = i$ then $u = v$. If either $i < n$ or $i < m$ then x is a fixed point, because $x = h_i \dots h_1 c = h_{i+1} h_i \dots h_1 c$. By the condition (SYM), $h_i \dots h_1 c^-$ is also a fixed point and, hence, we have again $u = v$, which concludes the proof.

Notice that, by virtue of Theorem 4.3, every symmetrical RH-algebra $AX = (X, G, LH, \leq)$ is a distributive lattice. Moreover, we have the following.

Theorem 5.2 For every symmetrical RH-algebra $AX = (X, G, LH, \leq)$, the following statements hold.

(i) $(hx)^- = hx^-$, for every $h \in LH$ and $x \in X$.

(ii) $(x^-)^- = x$, for every $x \in X$.

(iii) $hx > x$ iff $hx^- < x^-$, for every $h \in LH$ and $x \in X$.

(iv) $hx > kx$ iff $hx^- < kx^-$, for any $h, k \in LH$ and $x \in X$.

(v) $x < y$ iff $x^- > y^-$, for any $x, y \in X$.

(vi) $(x \cup y)^- = x^- \cap y^-$ and $(x \cap y)^- = x^- \cup y^-$, for any $x, y \in X$, where \cup and \cap stand for join and meet, respectively, in AX .

Proof. See Appendix C.

6 ALGEBRAIC STRUCTURES OF FINITE SYMMETRICAL RH_ALGEBRAS.

It is well-known that to model logical operations, in investigations of $[0,1]$ -valued fuzzy logics (e.g. [12,15,13,16,26]) ones have extended respective Boolean logical operations to the unit interval $[0,1]$ mainly by using t -norms and t -conorms. For example, one way of extending the classical binary implication to the interval $[0,1]$ by using a t -norm T is to define the *residuation*

$$R_T(x, y) = \text{Sup}\{z \in [0,1] : T(x, z) \leq y\}.$$

An another extension of the implication is to take advantage of the equivalence between statements “NOT A OR B ” and “IF A THEN B ” in Boolean logic to define the so-called S -implication

$$I_T(x, y) = S(1 - x, y) = 1 - T(x, 1 - y),$$

where T is a t -norm and S is its dual t -conorm.

Several $[0,1]$ -valued propositional logics such as Łukasiewicz logic, Gödel logic, and Product logic can be axiomatised and their algebraic versions are algebraic structures of the interval $[0,1]$ such as MV-algebra, Heyting algebra and Product algebra, respectively, (cf [26]). It should be also emphasised that in dealing with formalised mathematical theories, ones have discovered the close relation between logics and abstract algebras (e.g., [31,32]).

Motivation by such a view, in this section we shall discuss some algebraic structures of finite symmetrical RH-algebras. It is shown that in these algebras we are able to define operations, which, according to their properties, may be used to model logical operations in a fuzzy linguistic logic.

Let us consider a symmetrical RH-algebra $AX = (X, G, LH, \leq)$ with $G = \{\mathbf{1}, a^+, \mathbf{W}, a^-, \mathbf{0}\}$ where a^+ is the positive generator and a^- is the negative one.

It is known that the RH_algebra AX under consideration is a distributive lattice. Thus, the lattice operations join and meet, can model the semantics of the logical disjunction and conjunction. Now, we show that the operator $\bar{}$ can be interpreted as a negation.

Let $AX = (X, G, LH, \leq)$ be a symmetrical RH_algebra, where underlying set X is defined as follows.

First, we define $LH_n[G]$, for $n \geq 0$, by the following procedure:

$$LH_0[G] = G, LH_1[G] = LH[G] = \bigcup_{a \in G} \{ha : h \in LH + I\},$$

$$LH_{n+1}[G] = LH[LH_n[G]].$$

It is easily seen that

$$G \subset LH[G] \subset LH_2[G] \subset \dots \subset LH_n[G] \subset \dots$$

In general, this chain is infinite. However, in applications, we use only a bounded number of hedges in concatenation and, hence, this chain of inclusions will be stationary. Thus, let p be a fixed positive integer and assume that for any $x \in LH_p[G]$ and $x \notin LH_{p-1}[G]$, $hx = x$ holds, for every $h \in LH$ and so, we have $G \subset LH[G] \subset LH_2[G] \subset \dots \subset LH_p[G]$. Let $X = LH_p[G]$. Clearly, $AX = (LH_p[G], G, LH, \leq)$ is well-defined. It is known that this algebra AX is a complete distributive lattice.

As observed by Ho and Wechler in [9], the negation of vague concept may often be the concept having the opposite meaning, if it exists. For example, ‘good’ and ‘true’ are vague concepts and they involve an intuitively intended meaning. Refuting this meaning, one may often think of the meaning of the concepts ‘bad’ and ‘false’, that have the opposite meaning (the antonym) to ‘good’ and ‘true’ and vice-versa. This interpretation was adopted in many investigations of fuzzy reasoning (see, e.g., [28,35,38]). Certainly, it may still be possible to discuss how to refute statements containing vague concepts which are not primary concepts such as ‘Very little true’. However, it is natural to regard the negation of ‘Very little true’ as to be a concept of ‘false’ and it may most probably be the concept ‘Very little false’, which has the opposite meaning to the concept ‘Very little true’. This gives us a way to define the logical negation. However, the important thing is to show that the negation defined in this way has sufficient properties to develop a fuzzy logic. Note that the hedge algebras involve a fuzziness in their structure.

Therefore, analogous to the paper [9] by Ho and Wechler, we now define the negation of an element x in AX to be its contradictory element, i.e. $\bar{x} = x^-$. This operation $\bar{}$ is called *concept-negation* operation, because the elements of AX can be considered as linguistic terms, i.e. vague concepts. The *concept-implication* operation in this algebra, denoted by \Rightarrow , is defined in this paper in a regular way, i.e. by means of the negation and the join operations, as follows:

$$x \Rightarrow y = \bar{x} \cup y, \quad \text{for any } x \text{ and } y \text{ of } AX.$$

Let $AX = (X, G, LH, \leq)$, with $G = \{\mathbf{1}, a^+, \mathbf{W}, a^-, \mathbf{0}\}$ and underlying set X defined as above, be a finite symmetrical RH-algebra. As examined above, the operations $\cup, \cap, \neg, \Rightarrow$ can be derived in AX and so, we can write

$$AX = (X, G, LH, \leq, \neg, \cup, \cap, \Rightarrow, \mathbf{0}, \mathbf{W}, \mathbf{1}).$$

We are now ready to establish some elementary properties of the negation operation and the implication operation.

Theorem 6.1 *Let AX be a finite symmetrical RH-algebra. Then*

- (i) $\neg(hx) = h\neg x$, for every $h \in LH$ and $x \in X$.
- (ii) $\neg(\neg x) = x$, for all $x \in X$.
- (iii) $\neg(x \cup y) = \neg x \cap \neg y$ and $\neg(x \cap y) = \neg x \cup \neg y$, for all $x, y \in X$.
- (iv) $x \cap \neg x \leq y \cup \neg y$, for all $x, y \in X$.
- (v) $x \cap \neg x \leq \mathbf{W} \leq x \cup \neg x$, for all $x \in X$.
- (vi) $\neg \mathbf{1} = \mathbf{0}, \neg \mathbf{0} = \mathbf{1}$ and $\neg \mathbf{W} = \mathbf{W}$.
- (vii) $x > y$ iff $\neg x < \neg y$, for all $x, y \in X$.

Proof. It is immediately deduced from the definition of the operations defined above and Theorem 5.2.

It is worth to mention that the statements (ii) – (iv) of Theorem 6.1 show that the algebra AX is a Kleene algebra in the sense of Skala [34] and (vi) shows that this algebra includes the 3-valued Łukasiewicz algebra $\{\mathbf{0}, \mathbf{W}, \mathbf{1}\}$ as its subalgebra. At the same time, the statements (ii) – (iii) show that the triple (\cap, \cup, \neg) is a De Morgan system and AX becomes a Morgan algebra⁴ in the sense of Negoita and Ralescu [29].

As a consequence of the definition of the concept-implication operation and Theorem 6.1, we have the following.

Theorem 6.2 *Let $AX = (X, G, LH, \leq, \neg, \cup, \cap, \Rightarrow, \mathbf{0}, \mathbf{W}, \mathbf{1})$ be a finite symmetrical RH-algebra. Then,*

- (i) $x \Rightarrow y = \neg y \Rightarrow \neg x$,
- (ii) $x \Rightarrow (y \Rightarrow z) = y \Rightarrow (x \Rightarrow z)$,
- (iii) $x \Rightarrow y \geq x' \Rightarrow y'$ if $x \leq x'$ and/or $y \geq y'$,

⁴⁾ Also named *Soft algebra*

$$(iv) \quad x \Rightarrow y = \mathbf{1} \text{ iff } x = \mathbf{0} \text{ or } y = \mathbf{1},$$

$$(v) \quad \mathbf{1} \Rightarrow x = x \text{ and } x \Rightarrow \mathbf{1} = \mathbf{1}; \mathbf{0} \Rightarrow x = \mathbf{1} \text{ and } x \Rightarrow \mathbf{0} = \neg x,$$

$$(vi) \quad x \Rightarrow y \geq \mathbf{W} \text{ iff either } x \leq \mathbf{W} \text{ or } y \geq \mathbf{W}, \text{ and } x \Rightarrow y \leq \mathbf{W} \text{ iff } x \geq \mathbf{W} \text{ and } y \leq \mathbf{W}.$$

The statement (iv) of Theorem 6.2 shows that the concept-implication operation \Rightarrow is an extension of the implication operation in the two-element Boolean algebra $\{\mathbf{0}, \mathbf{1}\}$.

On the other hand, since the finite symmetrical RH_algebra $AX = (X, G, LH, \leq)$ is a distributive lattice, it is known [1,32] that AX is a relatively pseudo-complement lattice. That is, for any $x, y \in X$, the pseudo-complement of x relative to y , denoted by $x \rightarrow y$, always exists, i.e. $x \rightarrow y$ is the greatest element of the set of elements z in X such that $x \cap z \leq y$. We now formulate fundamental properties of the operation \rightarrow in finite symmetrical RH_algebras in the following theorem. The proof of the theorem can be found in [32] (Theorem 12.2).

Theorem 6.3 *Let AX be a finite symmetrical RH_algebra. Then,*

1. $x \rightarrow y = \mathbf{1}$ iff $x \leq y$,
2. $\mathbf{1} \rightarrow y = y; \mathbf{0} \rightarrow y = \mathbf{1}$,
3. $x \cap (x \rightarrow y) \leq y$,
4. If $x_1 \leq x_2$ then $x_2 \rightarrow y \leq x_1 \rightarrow y$,
5. If $y_1 \leq y_2$ then $x \rightarrow y_1 \leq x \rightarrow y_2$,
6. $x \cap (x \rightarrow y) = x \cap y$,
7. $(x \rightarrow y) \cap y = y$,
8. $(x \rightarrow y) \cap (x \rightarrow z) = x \rightarrow (y \cap z)$,
9. $(x \rightarrow z) \cap (y \rightarrow z) = (x \cup y) \rightarrow z$,
10. $x \rightarrow (y \rightarrow z) = (x \cap y) \rightarrow z = y \rightarrow (x \rightarrow z)$,
11. $z \rightarrow x \leq (z \rightarrow (x \rightarrow y)) \rightarrow (z \rightarrow y)$,
12. $(x \rightarrow y) \cap (y \rightarrow z) \leq x \rightarrow z$,
13. $x \leq y \rightarrow (x \cap y)$,
14. $x \rightarrow (y \rightarrow z) \leq (x \rightarrow y) \rightarrow (x \rightarrow z)$,

$$15. z \cap ((z \cap x) \rightarrow (z \cap y)) = z \cap (x \rightarrow y).$$

It is interesting to note that the statements 1) and 4)-7) of Theorem 6.3 show that the algebra $AX = (X, G, LH, \leq, \cup, \cap, \rightarrow, \mathbf{0}, \mathbf{1})$ is a Heyting (pseudo-Boolean) algebra. Furthermore, we are able to define another negation operation, denoted by \sim , via \cap -complement operation as follows

$$\sim x = x \rightarrow \mathbf{0}, \text{ for any } x \text{ in } X.$$

Consequently, by definition, we get

$$\sim x = \begin{cases} \mathbf{1} & \text{if } x = \mathbf{0}, \\ \mathbf{0} & \text{otherwise.} \end{cases}$$

The fundamental properties of the negation operation \sim in finite symmetrical RH-algebras are given in the following theorem.

Theorem 6.4 *In every finite symmetrical RH-algebra AX ,*

1. *If $x \leq y$ then $\sim y \leq \sim x$,*
2. *$\sim \mathbf{1} = \mathbf{0}, \sim \mathbf{0} = \mathbf{1}$,*
3. *$x \cap \sim x = \mathbf{0}, \sim (x \cap \sim x) = \mathbf{1}$,*
4. *$\sim (x \cup y) = \sim x \cap \sim y, \sim x \cup \sim y \leq \sim (x \cap y)$,*
5. *$\sim x \cup y \leq x \rightarrow y, x \rightarrow y \leq \sim y \rightarrow \sim x$,*
6. *$x \rightarrow \sim y = \sim (x \cap y) = y \rightarrow \sim x$,*
7. *$\sim \sim (x \rightarrow y) \leq x \rightarrow \sim \sim y$.*

The proof of theorem can follow directly from the proof of Theorem 12.3 [32].

To close this section, we shall point out that the class of the symmetrical RH-algebras and the class of pseudo-complement symmetrical RH-algebras are not included in class of BL-algebras.

Firstly we need a notion: a symmetrical RH-algebra $AX = (X, G, LH, \leq, \neg, \cup, \cap, \Rightarrow, \mathbf{0}, \mathbf{W}, \mathbf{1})$ is said to be *degenerated* if H^+ and H^- are not empty and $hc = c$ for every $h \in H$ and $c \in \{a^+, a^-\} \subset G$. In the symmetrical algebras, it can easily shown that AX is *non-degenerated* if H^+ and H^- are not empty and $hc \neq c$ for some $h \in H$ and $c \in \{a^+, a^-\} \subset G$.

Theorem 6.5 1) *Each non-degenerated symmetrical RH-algebra*

$$AX = (X, G, LH, \leq, \neg, \cup, \cap, \Rightarrow, \mathbf{0}, \mathbf{W}, \mathbf{1})$$

with the product $\bullet = \cap$ is not a residuated lattice.

2) Each non-degenerated pseudo-complement symmetrical RH_algebra $AX = (X, G, LH, \leq, \cup, \cap, \rightarrow, \mathbf{0}, \mathbf{1})$ with H^- containing at least two incomparable hedge operations, denoted for example by *Poss*(possibly) and *App*(approximately), is not a BL_algebra.

Proof. It is known that a lattice L is residuated if the condition “ $\forall x, y, x \in L, x \bullet y \leq z$ iff $x \leq y \Rightarrow z$ ” holds (see [36]). Take three elements $y = True, z = VeryFalse$ and $x = y \Rightarrow z = \neg y \cup z = False \cup VeryFalse = False$, where $G = \{False, \mathbf{W}, True\}$ and $Very \in H^+$. Clearly, we have $x \bullet y = x \cap y = False > VeryFalse = z$. This shows that the statement 1) is valid.

To prove 2), without loss of generality we suppose that $G = \{False, \mathbf{W}, True\}$ and $False < \mathbf{W} < True$. Put $x = AppFalse, y = PossFalse$. Clearly, $x < \mathbf{W}$ and $y < \mathbf{W}$, x and y are incomparable and $(x \rightarrow y) \cup (y \rightarrow z) \leq \mathbf{W} \leq \mathbf{1}$. The last inequality shows (see [36]) that AX is not a BL_algebra.

7 CONCLUSIONS.

In this paper RH_algebras have been introduced and investigated. Many interesting properties of RH_algebra have been examined. They show that RH_algebras have a rich enough algebraic structure and, therefore, these algebras can be taken as an algebraic basis for a kind of fuzzy logic. It is worthwhile to emphasise that the axioms of RH_algebras express natural properties of linguistic hedges and linguistic terms that can be formulated in terms of a designed ordering relation (called semantically ordering relation). Thus, these axioms can be considered as an axiomatization of linguistic domains of linguistic variables. If we agree that RH_algebras can be taken as an algebraic foundation for a kind of fuzzy logic, then the important result of our approach is that this logic structure can be constructed merely based on semantic properties of hedges and vague concepts in natural language.

Since, as we have observed, there is a close relationship between the algebraic structure of sets of truth values and characteristics of the logics based on these sets, RH_algebras may provide new characteristics of certain fuzzy logics. It is shown [4,5] that RH_algebras can give a basis to study new methods in fuzzy reasoning and, it can be observed, that these methods are qualitative.

APPENDIXES

Appendix A. The proof of Theorem 4.1

From (A4) it follows that if x and y are incomparable in X , then there exists an element $a \in G$ such that $x, y \in LH(a)$, since G is a chain. Thus, there exist two canonical representations of x and y w.r.t. a , say

$x = h_n \dots h_1 a$ and $y = k_m \dots k_1 a$. On account of Theorem 3.3, there exists an index $j \leq \min\{m, n\} + 1$ such that $h_i = k_i$, for any $i \leq j$. Furthermore, there exists $i_0 \in SI^c$ such that $h_j, k_j \in LH_{i_0}^c$. Let $\delta = h_n \dots h_{j+1}, \gamma = k_m \dots k_{j+1}, h = h_j, k = k_j$. With this notations we have $x = \delta h w$ and $y = \gamma k w$, where $w = h_{j-1} \dots h_1 a$.

Since the proof for the meet can be obtained by duality, we shall only prove the formulas for the join.

Let us first consider the case where $h w > w$. Then, we also have $k w > w$. It implies that $(h \vee k) w > w$ and $h \vee k \in LH_{i_0}^c$, since $LH_{i_0}^c$ is a sublattice of $LH^c + I$. By Definition 3.2 and (A4), we have $\delta(h \vee k) w \geq \delta h w = x$ and $\gamma(h \vee k) w \geq \gamma k w = y$.

Now, we shall prove that for any $z \in LH(a)$ such that $z > \{x, y\}$, the inequality $z \geq \{\delta(h \vee k) w, \gamma(h \vee k) w\}$ holds.

Suppose that $z = t_p \dots t_1 a$ is the canonical representation of z w.r.t. a and suppose firstly that $z \in LH(w)$. So, we have $z = t_p \dots t_{j+1} t_j w$. Since $z > \{x, y\}$ it follows from Theorem 3.3 that $t_j w > \{h w, k w\}$. Remember that $h w > w$, and hence, it implies that $t_j \geq h \vee k$ and $t_j w \geq (h \vee k) w$. In the case that $t_j \notin LH_{i_0}^c$, by (v) of Theorem 3.1 we obtain $t_j w \gg (h \vee k) w$ and so, we infer that $z > \{\delta(h \vee k) w, \gamma(h \vee k) w\}$.

In the case that $t_j \in LH_{i_0}^c$, let the equality $t_j w = (h \vee k) w$ hold. If $t_j \neq (h \vee k)$, then by (iv) of Theorem 3.1, w is a fixed point and hence $w = h w$, which is contrary to the just adopted assumption. Thus, $t_j = (h \vee k)$. Since $t_j w > h w, t_j w > k w$ and $z > \{x, y\}$, it follows from Theorem 3.3 the following desired inequalities $z \geq \{\delta(h \vee k) w, \gamma(h \vee k) w\}$.

Now, assume that $t_j w > (h \vee k) w$. Thus, $z = t_p \dots t_j w > t_p \dots t_{j+1} (h \vee k) w$, by (A4). Since $z > \{x, y\}$ and, as it is easily verified, $x = \delta h w < \delta t_j w, y = \gamma k w < \gamma t_j w$, we infer again by (A4), that $z \geq \{\delta t_j w, \gamma t_j w\}$. Applying Proposition 3.4 to the last inequalities, we obtain $t_p \dots t_{j+1} (h \vee k) w \geq \{\delta(h \vee k) w, \gamma(h \vee k) w\}$. Hence, $z > \{\delta(h \vee k) w, \gamma(h \vee k) w\}$, which are the desired inequality.

Now, we are going to suppose that $z \notin LH(w)$. Then, there exists an index $j_1 \leq j - 1$ such that $h_i = t_i$ for any $i < j_1$, and $t_{j_1} u > h_{j_1} u$, where $u = h_{j_1-1} \dots h_1 a$. If there is no index $i_1 \in SI^c$ such that both $t_{j_1}, h_{j_1} \in LH_{i_1}^c$ then it follows from (i) of Corollary 3.1 that $z > \{\delta(h \vee k) w, \gamma(h \vee k) w\}$. In the case there exists $i_1 \in SI^c$ such that $t_{j_1}, h_{j_1} \in LH_{i_1}^c$, we shall prove the assertion by induction on the number $s = j - j_1 - 1$ of hedge operations as follows.

For $s = 0$, i.e. $j_1 = j - 1$ and $w = h_{j-1} u$, it follows from (ii) of Theorem 3.3 that $z \geq \{\delta h t_{j-1} u, \gamma k t_{j-1} u\}$, because $t_{j-1} u > h_{j-1} u$. Since $h w = h h_{j-1} u > h_{j-1} u = w$ and the elements $x = \delta h h_{j-1} u$ and $y = \gamma k h_{j-1} u$ are incomparable, it follows from Proposition 3.4 that $h t_{j-1} u > t_{j-1} u$ and that $\delta h t_{j-1} u$ and $\gamma k t_{j-1} u$ are incomparable. Clearly, $z \in LH(t_{j-1} u)$ and, analogously to the case where $z \in LH(w)$ and $w = t_{j-1} u$, we can prove that $z \geq \{\delta(h \vee k) t_{j-1} u, \gamma(h \vee k) t_{j-1} u\}$. Moreover, it follows from (A4), that

$$\delta(h \vee k) t_{j-1} u > \delta(h \vee k) h_{j-1} u = \delta(h \vee k) w \quad \text{and} \quad \gamma(h \vee k) t_{j-1} u > \gamma(h \vee k) h_{j-1} u = \gamma(h \vee k) w.$$

Thus, $z > \{\delta(h \vee k)w, \gamma(h \vee k)w\}$.

Assume the induction hypothesis saying that the inequality holds for every $s \leq i$. For $s = i + 1$, we have $j_1 + i + 1 = j - 1$ and $w = h_{j-1} \dots h_{j_1+1} h_{j_1} u$. Set $w' = h_{j-1} \dots h_{j_1+1} t_{j_1} u$. It follows from Proposition 3.4 that $hw' > w'$, since $hw > w$ and $t_{j_1}, h_{j_1} \in LH_{i_1}^c$. Using (A4) again, we get

$$z \geq \{\delta h h_{j-1} \dots h_{j_1+1} t_{j_1} u, \gamma k h_{j-1} \dots h_{j_1+1} t_{j_1} u\}$$

and, by Proposition 3.4, $\delta h h_{j-1} \dots h_{j_1+1} t_{j_1} u$ and $\gamma k h_{j-1} \dots h_{j_1+1} t_{j_1} u$ are incomparable. If $z \in LH(w')$ then, by the same argument as for the case $z \in LH(w)$, we obtain

$$z \geq \{\delta(h \vee k)h_{j-1} \dots h_{j_1+1} t_{j_1} u, \gamma(h \vee k)h_{j-1} \dots h_{j_1+1} t_{j_1} u\}.$$

Hence, by (A4) applied to $t_{j_1} u > h_{j_1} u$, we have $z > \{\delta(h \vee k)w, \gamma(h \vee k)w\}$.

If $z \notin LH(w')$ then there exists an index j_2 such that $j_1 + 1 \leq j_2 \leq j - 1$, $h_{i'} = t_{i'}$ for any i' satisfying $j_2 > i' \geq j_1 + 1$, and $t_{j_2} u' > h_{j_2} u'$, where $u' = t_{j_2-1} \dots t_{j_1} u$. By a similar argument as in the previous case where $z \notin LH(w)$, it can be seen that if there is no $i_2 \in SI^c$ such that $t_{j_2}, h_{j_2} \in LH_{i_2}^c$ then $z > \{\delta(h \vee k)w', \gamma(h \vee k)w'\}$ and hence, $z > \{\delta(h \vee k)w, \gamma(h \vee k)w\}$.

Conversely, if there exists $i_2 \in SI^c$ such that $t_{j_2}, h_{j_2} \in LH_{i_2}^c$ then, by the induction hypothesis, we have

$$z \geq \{\delta(h \vee k)h_{j-1} \dots h_{j_2+1} t_{j_2} u', \gamma(h \vee k)h_{j-1} \dots h_{j_2+1} t_{j_2} u'\}.$$

Since $t_{j_2} u' > h_{j_2} u'$, we get

$$\delta(h \vee k)h_{j-1} \dots h_{j_2+1} t_{j_2} u' > \delta(h \vee k)h_{j-1} \dots h_{j_2+1} h_{j_2} u' > \delta(h \vee k)w$$

and

$$\gamma(h \vee k)h_{j-1} \dots h_{j_2+1} t_{j_2} u' > \gamma(h \vee k)h_{j-1} \dots h_{j_2+1} h_{j_2} u' > \gamma(h \vee k)w.$$

So, $z > \{\delta(h \vee k)w, \gamma(h \vee k)w\}$, which is what we desire.

For the case where $hw < w$, we infer $kw < w$. In addition, we observe that $\delta(h \wedge k)w \geq \delta hw$ and $\gamma(h \wedge k)w \geq \gamma kw$. By an analogous argument as above, we can prove that $z \geq \{\delta(h \wedge k)w, \gamma(h \wedge k)w\}$, for any $z \in LH(a)$ such that $z > \{x, y\}$.

Therefore, we have proved that if the join of the two elements on the right hand side exists, then so does the join of x and y and we have $x \cup y = \delta hw \cup \gamma kw = \delta w' \cup \gamma w'$, where $w' = (h \vee k)w$ if $hw > w$ and $w' = (h \wedge k)w$ if $hw < w$.

So, it remains to prove is that the joins on the right hand side of the equalities of the theorem always exist. As an example, we shall prove the join in which $w' = (h \vee k)w$ occurs. Indeed, we shall prove it by

induction on the length of string δ of hedges. If $|\delta| = 0$ then the required assertion is evident, since $(h \vee k)w$ and $\gamma(h \vee k)w$ are comparable. Assume that the required assertion holds for all $|\delta| \leq i$. As previously, we shall prove the induction conclusion for the case where $hw > w$. For $|\delta| = i + 1$, if $\delta(h \vee k)w$ and $\gamma(h \vee k)w$ are comparable then the conclusion is clearly true. Let $x' = \delta(h \vee k)w$ and $y' = \gamma(h \vee k)w$ be incomparable. Then, we can use the same argument as in the proof for x and y to prove that for any $z \in X$, if $z > \{x', y'\}$ then $z \geq \{\delta_1(h' \vee k')w', \gamma_1(h' \vee k')w'\}$, where h', k' satisfy the same assumption like that adopted on h and k . Because $|\delta_1| \leq i$, by the induction hypothesis the join of $\delta_1(h' \vee k')w'$ and $\gamma_1(h' \vee k')w'$ does exist.

Since the proof for the case where $hw < w$ is similar, the theorem is completely proved.

Appendix B. Proof of Theorem 4.3

Suppose the contrary that AX is not distributive. On account of Theorem 4.2, it implies that either N_5 or M_5 can be embedded into AX as its sublattice. Assume for example that it is N_5 , i.e. there exist elements $x, y, z \in X$ such that x and y are comparable, say $x > y$, but each pair of x and z, y and z is incomparable and the following equalities hold: $x \cap z = y \cap z$ and $x \cup z = y \cup z$. It can be seen that there exists $a \in G$ such that all elements $x, y, z, x \cap z, x \cup z$ belong to $LH(a)$.

Suppose that $x = h_n \dots h_1 a, y = k_m \dots k_1 a$ and $z = t_p \dots t_1 a$ are canonical representations of x, y, z w.r.t. a , respectively. By Theorem 3.3, there exists an index $j \leq \min\{n, m, p\} + 1$ such that $h_{j'} = k_{j'} = t_{j'}$ for any $j' < j$, and at least one of the two operations h_j and k_j is different from t_j , say $h_j \neq t_j$. Since x and z are incomparable, by Theorem 3.3, h_j and t_j must belong to the same $LH_{i_0}^c$, for some $i_0 \in SI^c$. Set $w = h_{j-1} \dots h_1 a, \delta_x = h_n \dots h_{j+1}, \delta_y = k_m \dots k_{j+1}$ and $\delta_z = t_p \dots t_{j+1}$.

If $k_j = t_j$ then $t_j w < h_j w$, by Theorem 3.3. It follows from Theorem 4.1 that $x \cup z \in LH(h_j w)$ and $y \cup z \in LH(t_j w)$ and so $x \cup z \neq y \cup z$, which contradicts the adopted hypothesis. Thus, $k_j \neq t_j$. If $k_j \notin LH_{i_0}^c$ then $k_j w < h_j w$ and, by Remark 3.1, we also have $k_j w < h_j w$. Hence, by Theorem 3.3, we obtain $y < z$, which contradicts to the comparability of y and z . Thus, $k_j \in LH_{i_0}^c$. According to Theorem 4.1, it follows that if $h_j w > w$, then

$$x \cup z \in LH((h_j \vee t_j)w), y \cup z \in LH((k_j \vee t_j)w), x \cap z \in LH((h_j \wedge t_j)w), y \cap z \in LH((k_j \wedge t_j)w),$$

and if $h_j w < w$, then

$$x \cup z \in LH((h_j \wedge t_j)w), y \cup z \in LH((k_j \wedge t_j)w), x \cap z \in LH((h_j \vee t_j)w), y \cap z \in LH((k_j \vee t_j)w).$$

By virtue of (A4), it can easily be seen that $(h_j \vee t_j)w = (k_j \vee t_j)w$ and $(h_j \wedge t_j)w = (k_j \wedge t_j)w$, since $x \cup z = y \cup z$ and $x \cap z = y \cap z$. Consequently, it follows from (ii) of Corollary 4.1 that $h_j = k_j$.

Now, we shall show that *the assumption* that the existence of elements x, y and z such that the five-element

sublattice $\{x, y, z, x \cap z, x \cup z\}$ of AX is isomorphic onto N_5 will lead to a contradiction, by induction on the length $|\delta_x|$ of the string δ_x described above.

We shall only prove for the case $h_j w > w$, since the argument for the opposite case is similar. Assume that $|\delta_x| = 0$. Then, it follows from Theorem 4.1 that

$$x \cup z = (h_j \vee t_j)w \cup \delta_z(h_j \vee t_j)w, y \cup z = \delta_y(h_j \vee t_j)w \cup \delta_z(h_j \vee t_j)w,$$

and

$$x \cap z = (h_j \wedge t_j)w \cap \delta_z(h_j \wedge t_j)w, y \cap z = \delta_y(h_j \wedge t_j)w \cap \delta_z(h_j \wedge t_j)w.$$

Suppose that $(h_j \vee t_j)w$ is a fixed point. By Proposition 3.2, it implies that hw is a fixed point, for every $h \in LH_{i_0}^c$. By virtue of Theorem 3.3, it follows that the five-element lattice $\{x, y, z, x \cup z, y \cap x\}$ is isomorphic to the five-element sublattice $\{h_j w, k_j w, t_j w, (h_j \vee t_j)w, (h_j \wedge t_j)w\}$, which contradicts the fact that $LH[w]$ is distributive by (ii) of Corollary 4.1. Now suppose that $(h_j \vee t_j)w$ and $(h_j \wedge t_j)w$ are not fixed points. So, if $(h_j \vee t_j)w = \delta_z(h_j \vee t_j)w$ then $|\delta_z| = 0$, and hence, $x \cup z = (h_j \vee t_j)w, x \cap z = (h_j \wedge t_j)w$. Since $x > y$ and $h_j = k_j$, it follows from (iii) of Proposition 3.4 that $(h_j \vee t_j)w > \delta_y(h_j \vee t_j)w$ and $(h_j \wedge t_j)w > \delta_y(h_j \wedge t_j)w$. Thus, by Theorem 4.1, $y \cap z = \delta_y(h_j \wedge t_j)w$ and, hence, $x \cap z = (h_j \wedge t_j)w > y \cap z$, which is contrary to the structure of N_5 .

If $(h_j \vee t_j)w > \delta_z(h_j \vee t_j)w$ then, by (iii) of Proposition 3.4, $(h_j \wedge t_j)w > \delta_y(h_j \wedge t_j)w$, and again by Theorem 4.1, $x \cup z = (h_j \vee t_j)w$ and $x \cap z = \delta_z(h_j \wedge t_j)w$. On the other hand, since $y \cap z = \delta_y(h_j \wedge t_j)w \cap \delta_z(h_j \wedge t_j)w = x \cap z$, it follows that $\delta_y(h_j \wedge t_j)w \geq \delta_z(h_j \wedge t_j)w$. Also by Proposition 3.4, it implies that $\delta_y(h_j \vee t_j)w \geq \delta_z(h_j \vee t_j)w$, which yields $y \cup z = \delta_y(h_j \vee t_j)w < (h_j \vee t_j)w = x \cup z$, a contrary to the structure of N_5 .

By an analogous argument, the assumption $(h_j \vee t_j)w < \delta_z(h_j \vee t_j)w$ also leads to a contradiction. This concludes the proof for the case where $|\delta_x| = 0$.

Now suppose as the induction hypothesis that the adopted assumption will lead to a contradiction, for all x, y and z such that $|\delta_x| < i$. Let us consider any elements x, y and z , satisfying this assumption and $|\delta_x| = i$. It follows from Theorem 4.1 that

$$x \cup z = \delta_x(h_j \vee t_j)w \cup \delta_z(h_j \vee t_j)w, y \cup z = \delta_y(h_j \vee t_j)w \cup \delta_z(h_j \vee t_j)w,$$

and

$$x \cap z = \delta_x(h_j \wedge t_j)w \cap \delta_z(h_j \wedge t_j)w, y \cap z = \delta_y(h_j \wedge t_j)w \cap \delta_z(h_j \wedge t_j)w,$$

because $h_j w > w$.

Put $x' = \delta_x(h_j \vee t_j)w$, $y' = \delta_y(h_j \vee t_j)w$ and $z' = \delta_z(h_j \vee t_j)w$. On the account of Proposition 4.1, it can be seen that the five-element sublattice $\{x', y', z', x' \cap z', x' \cup z'\}$ is isomorphic to N_5 . Then, by an analogous argument as at the beginning of the proof, it follows that there exists an index j_1 such that $j < j_1 \leq \min\{n, m, p\} + 1$ and, for any $j' < j_1$, we have $h_{j'} = k_{j'} = t_{j'}$, $t_{j_1} \neq h_{j_1} = k_{j_1}$, where $t_{j_1}, h_{j_1} \in LH_{i_2}^c$, for some $i_2 \in SI^c$.

Set $w' = h_{j_1-1} \dots h_{j_1+1}(h_j \vee t_j)w$, $\delta'_x = h_n \dots h_{j_1+1}$, $\delta'_y = k_m \dots k_{j_1+1}$, $\delta'_z = t_p \dots t_{j_1+1}$. Note that $|\delta'_x| < i$, and, hence, according to the induction hypothesis, it leads to a contradiction. This shows that N_5 cannot be embedded into AX as its sublattice.

Similarly, we can prove that M_5 also cannot be embedded into AX as its sublattice. This concludes the proof.

Appendix C. Proof of Theorem 5.2

First, by definition of the special generators $\mathbf{1}$, \mathbf{W} and $\mathbf{0}$, it is easily seen that the assertions of the theorem are evident if $x \in \{\mathbf{1}, \mathbf{W}, \mathbf{0}\}$. So, we assume that both $x, y \in LH(\{a^+, a^-\})$.

The assertion (i) is a direct consequence of the definition of the contradictory elements. Assertion (ii) follows immediately from the fact that, for every $x \in X$, x^- is uniquely defined and x is a contradictory element of x^- .

Now we shall prove assertion (iii) by induction on the length of the canonical representations of x w.r.t. a generator.

Let $|x| = 1$, where $|x|$ denotes the length of the canonical representation of x w.r.t. a generator c . Clearly, $x = c \in \{a^+, a^-\}$. If $Vc > c$ and $hc > c$ then V and h are compatible. Thus, the inequality $hc^- < c^-$ follows from $Vc^- < c^-$. If $Vc < c$ and $hc > c$ then V and h are converse. Hence, $Vc^- > c^-$ implies $hc^- < c^-$. Since the proof for the other cases is similar, the assertion (iii) is true for $|x| = 1$.

Assume that (iii) holds for all x satisfying $|x| < i$. Let $u = hx$ with $|u| = i$ and consider the case that $kux > ux$. If k is positive w.r.t. h , then $hx > x$ and, by the induction hypothesis, $hx^- < x^-$. Hence, it implies that $kux^- < ux^-$ (note that the equality can not occur, by assumption (SYM)). Conversely, by the same argument, it can be proved that $ku^- < u^-$ implies $ku > u$. Since the remaining cases can be proved in a similar way, the proof of (iii) is completed.

Now, we prove (iv). If h and k are converse, then $hx > x > kx$ and by (iii) it implies that $hx^- < x^- < kx^-$. If h and k are compatible then $hx > kx > x$, which implies $h > k$ in $LH^c + I$ (by the assumption of the semantic consistency). By (iii), we have $kx^- < x^-$ and, hence, $hx^- < kx^-$. Note that, as above, the equality $hx^- = kx^-$ does not occur, since in the contrary case x^- is a fixed point and, hence, so is its contradictory element x , by (SYM).

The proof for the last two assertions will be more complicated. First, we prove (v). It is known that if $x \in LH(c)$ and $y \in LH(c')$, with $c \neq c'$, then $c > c'$ follows from $x > y$. By the definition of the contradictory

elements, $x^- \in LH(c')$ and $y^- \in LH(c)$ and, hence, $x^- < y^-$.

Now suppose that $x, y \in LH(c)$ and $x > y$, and $x = h_n \dots h_1 w, y = k_m \dots k_1 w$ are, respectively, the canonical representation of x and y w.r.t. w , where $w \in LH(c)$ and $h_1 \neq k_1$. Note that one of h_1 and k_1 may be the identity I and in the case, say, $h_1 = I$ we should have $h_n \dots h_2 = \epsilon$, the empty string of operations. From $x > y$ it follows that $h_1 w > k_1 w$, by Theorem 3.3. So by (iv), we have $h_1 w^- < k_1 w^-$.

Since $h_1 \neq k_1$, without loss of generality, we shall assume that $h_1 \neq I$ and prove by induction on the length $|\sigma|$ of the string $\sigma = h_n \dots h_1$ that $x^- < y^-$.

First consider the case where $|\sigma| = 1$, i.e. $x = h_1 w > y = k_m \dots k_1 w$. If there is no index i in SI^c such that both $h_1, k_1 \in LH_i^c$, then from the inequality $h_1 w^- < k_1 w^-$ above it follows by (1) of Theorem 3.3 that $x^- = h_1 w^- < y^-$. In the opposite case, i.e. there exists an index $i \in SI^c$ such that $h_1, k_1 \in LH_i^c$, from the inequality $x > y$, it follows again by (1) of Theorem 3.3 that $h_1 w \geq k_m \dots k_2 h_1 w$. If the equality $x = h_1 w = k_m \dots k_2 h_1 w$ occurs, then x is a fixed point and, hence, $k_1 w$ is also a fixed point, i.e. $y = k_1 w$. Then, by (SYM), $h_1 w^-$ and $k_1 w^-$ are also fixed points. Thus, $x^- = h_1 w^- < k_1 w^- = y^-$. If $h_1 w > k_m \dots k_2 h_1 w$, then $k_2 \neq I$ and, by Theorem 3.3, we have $h_1 w > k_2 h_1 w$. Hence, it follows from (iii) that $h_1 w^- < k_2 h_1 w^-$. Again by Theorem 3.3, the last inequality implies $h_1 w^- < k_m \dots k_2 h_1 w^-$. By (A4), we infer $k_m \dots k_2 h_1 w^- < k_m \dots k_2 k_1 w^-$ and so, $x^- = h_1 w^- < k_m \dots k_2 h_1 w^- < k_m \dots k_2 k_1 w^- = y^-$, which is what we require and the proof for the case $|\sigma| = 1$ is completed.

Now let us assume as the induction hypothesis saying that $x = h_n \dots h_1 w > y = k_m \dots k_1 w$ implies that $x^- = h_n \dots h_1 w^- < y^- = k_m \dots k_1 w^-$, for all strings of hedges σ with $|\sigma| < p$ and for any $w \in LH(c)$. To prove the induction conclusion let us consider $x = h_p \dots h_1 w$, i.e. $|\sigma| = p$.

If there is no index i in SI^c such that $h_1, k_1 \in LH_i^c$, then from $h_1 w^- < k_1 w^-$ it follows that $x^- < y^-$, by (1) of Theorem 3.3. If there exists an index i in SI^c such that both h_1 and k_1 together belong to LH_i^c , then from $x = h_p \dots h_1 w > y = k_m \dots k_1 w$, it follows again by Theorem 3.3 that $x = h_p \dots h_1 w \geq k_m \dots k_2 h_1 w$. Putting $y_1 = k_m \dots k_2 h_1 w$, it is clear that $y_1 > y$, by (A4). Since $h_1 w^- < k_1 w^-$, we have $y_1^- < y^-$ as a consequence of (A4). Applying Theorem 3.3 to two element x and y_1 , it follows that there exists an index j such that $2 \leq j \leq \min\{p, m\} + 1$ and $h_{j'} = k_{j'}$, for $2 \leq j' < j$. If $x = y_1$ then we have $p = m = j$ and $h_j w_{<j} = k_j w_{<j}$, where $w_{<j} = h_{j-1} \dots h_1 w$. Therefore, we have $h_j w_{<j}^- = k_j w_{<j}^-$, by (iv). Hence, $x^- = h_j w_{<j}^- = k_j w_{<j}^- = y_1^- < y^-$.

Now assume that $x > y_1$, by Theorem 3.3, it follows that $h_j w_{<j} > k_j w_{<j}$, and thus $h_j w_{<j}^- < k_j w_{<j}^-$, by (iv). Note that the length of the string $\sigma' = h_p \dots h_{j+1}$ is less than p . Therefore, by the induction hypothesis, it follows that $x^- = h_p \dots h_{j+1} h_j w_{<j}^- < y_1^- = k_m \dots k_{j+1} k_j w_{<j}^-$. Consequently, we have $x^- < y^-$. On account of (ii), it is evident that the sufficiency of (v) can be deduced directly from the necessity. This concludes the proof of (v).

To prove (vi), we find first, by (v), that $x = y$ iff $x^- = y^-$ and that x and y are incomparable iff x^- and y^- are incomparable. Since the proof for the equality $(x \cap y)^- = x^- \cup y^-$ can be obtained by duality, we shall only prove the validity of $(x \cup y)^- = x^- \cap y^-$.

If x and y are comparable then the assertion follows directly from (v). Suppose that x and y are incomparable and $x = h_n \dots h_1 w, y = k_m \dots k_1 w$ are the canonical representation of x and y w.r.t. w , respectively, such that $h_1 \neq k_1$, where $w \in LH(c)$ for some $c \in G \setminus \{\mathbf{W}\}$. We shall prove the assertion by induction on the length of the string $\sigma = h_n \dots h_1$, denoted by $|\sigma|$.

First, let us suppose that $|\sigma| = 1$, i.e. $x = h_1 w$. By Theorem 3.3, it follows that there exists an index i in SI^c such that $h_1, k_1 \in LH_i^c$. By Theorem 4.1, we have

$$x \cup y = \begin{cases} (h_1 \vee k_1)w \cup k_m \dots k_2(h_1 \vee k_1)w & \text{if } h_1 w > w, \\ (h_1 \wedge k_1)w \cup k_m \dots k_2(h_1 \wedge k_1)w & \text{if } h_1 w < w. \end{cases}$$

Recall that LH_i^c is a sublattice of $LH^c + I$. Hence, if $h_1 w > w$ then $(h_1 \vee k_1)w > w$. If $h_1 w$ is a fixed point, then so are $(h_1 \vee k_1)w$ and $k_1 w$, by Proposition 3.1. In this case, $y = k_1 w$ and $x \cup y = (h_1 \vee k_1)w$. By (SYM), it follows that $h_1 w^-, k_1 w^-, (h_1 \vee k_1)w^-$ are also fixed points, i.e. $x^- = h_1 w^-, y^- = k_1 w^-$. On the other hand, by (iii), it follows from $h_1 w > w$ that $h_1 w^- < w^-$. Thus, by Theorem 4.1, we have $x^- \cap y^- = (h_1 \vee k_1)w^- = (x \cup y)^-$.

Now assume that $h_1 w$ is not a fixed point. If k_2 is positive w.r.t. $(h_1 \vee k_1)$, then $k_2(h_1 \vee k_1)w > (h_1 \vee k_1)w$. Notice that the equality can not occur, since if $k_2(h_1 \vee k_1)w = (h_1 \vee k_1)w$, then $(h_1 \vee k_1)w$ is a fixed point and, hence, so is $h_1 w$, a contradiction. By Theorem 3.3, we have $k_m \dots k_2(h_1 \vee k_1)w > (h_1 \vee k_1)w$, which yields $x \cup y = k_m \dots k_2(h_1 \vee k_1)w$. By the definition of the contradictory elements, we have $(x \cup y)^- = k_m \dots k_2(h_1 \vee k_1)w^-$. On the other hand, by (iii), from $k_2(h_1 \vee k_1)w > (h_1 \vee k_1)w$ it follows that $k_2(h_1 \vee k_1)w^- < (h_1 \vee k_1)w^-$. Consequently, $k_m \dots k_2(h_1 \vee k_1)w^- < (h_1 \vee k_1)w^-$, by Theorem 3.3. Thus, $x^- \cap y^- = k_m \dots k_2(h_1 \vee k_1)w^-$, which is the requirement.

Since the proof for the case $h_1 w < w$ is similar, it concludes the proof for the case $|\sigma| = 1$.

Now, let us suppose that $(x \cup y)^- = x^- \cap y^-$ holds for all x and y with $|\sigma| < p$ and $w \in LH(c)$. We shall prove the induction conclusion for $x = h_p \dots h_1 w$ and $|\sigma| = p$.

Since x and y are incomparable, it follows from Theorem 3.3 that there exists an index i in SI^c such that $h_1, k_1 \in LH_i^c$. Moreover, by Theorem 4.1, we have

$$x \cup y = \begin{cases} h_p \dots h_2(h_1 \vee k_1)w \cup k_m \dots k_2(h_1 \vee k_1)w & \text{if } h_1 w > w, \\ h_p \dots h_2(h_1 \wedge k_1)w \cup k_m \dots k_2(h_1 \wedge k_1)w, & \text{if } h_1 w < w. \end{cases}$$

First, assume that $h_1 w > w$. By (iii), $h_1 w^- < w^-$ and by (v), x^- and y^- are incomparable. So, on the account of Theorem 4.1, we have $x^- \cap y^- = h_p \dots h_2(h_1 \vee k_1)w^- \cap k_m \dots k_2(h_1 \vee k_1)w^-$, where $x^- = h_p \dots h_1 w^-$ and $y^- = k_m \dots k_1 w^-$. If $h_p \dots h_2(h_1 \vee k_1)w$ and $k_m \dots k_2(h_1 \vee k_1)w$ are comparable, then it is obvious by (v) that

$$(x \cup y)^- = (h_p \dots h_2(h_1 \vee k_1)w \cup k_m \dots k_2(h_1 \vee k_1)w)^- = h_p \dots h_2(h_1 \vee k_1)w^- \cap k_m \dots k_2(h_1 \vee k_1)w^- = x^- \cap y^-,$$

which is the desired equality.

If $x_1 = h_p \dots h_2(h_1 \vee k_1)w$ and $y_1 = k_m \dots k_2(h_1 \vee k_1)w$ are incomparable then, by Theorem 3.3, there exists an index j such that $2 \leq j < \min\{p, m\} + 1$ and $h_{j'} = k_{j'}$ for all j' satisfying $2 \leq j' < j$, and there exists an index i' in SI^c such that $h_j, k_j \in LH_{i'}^c$. Thus, it follows from Theorem 4.1 that

$$x_1 \cup y_1 = \begin{cases} h_p \dots h_{j+1}(h_j \vee k_j)w_{<j} \cup k_m \dots k_{j+1}(h_j \vee k_j)w_{<j} & \text{if } h_j w_{<j} > w_{<j}, \\ h_p \dots h_{j+1}(h_j \wedge k_j)w_{<j} \cup k_m \dots k_{j+1}(h_j \wedge k_j)w_{<j} & \text{if } h_j w_{<j} < w_{<j}, \end{cases}$$

where $w_{<j} = h_{j-1} \dots h_2(h_1 \vee k_1)w$. Clearly, $|\sigma'| < p$, where $\sigma' = h_p \dots h_{j+1}$.

If $h_j w_{<j} > w_{<j}$ then $h_j w_{<j}^- < w_{<j}^-$, by (iii). Note that, as proved above, x_1^- and y_1^- are incomparable. Therefore, again by Theorem 4.1,

$$x^- \cap y^- = h_p \dots h_{j+1}(h_j \vee k_j)w_{<j}^- \cap k_m \dots k_{j+1}(h_j \vee k_j)w_{<j}^- = x_1^- \cap y_1^-.$$

Now, combining the obtained equalities and taking into account the induction hypothesis, we obtain

$$(x \cup y)^- = (h_p \dots h_{j+1}(h_j \vee k_j)w_{<j} \cup k_m \dots k_{j+1}(h_j \vee k_j)w_{<j})^- = (x_1 \cup y_1)^- = x_1^- \cap y_1^- = x^- \cap y^-.$$

For the case $h_j w_{<j} < w_{<j}$, the proof is similar. Since the proof for the case $h_1 w < w$, can be obtained by duality, the theorem is completely proved.

ACKNOWLEDGEMENTS

We are indebted to L. Godo (FSS Area Editor in AI) for interesting and helpful remarks. We also thank two anonymous referees for their valuable comments and suggestions.

REFERENCES

1. G. Birkhoff, *Lattice Theory* (Providence, Rhode Island, 1973).
2. S. Burris & H. P. Sankappanavar, *A Course in Universal Algebras* (Springer-Verlag: New York-Heidelberg-Berlin, 1981).
3. N. Cat Ho, Fuzziness in structure of linguistic truth values: A foundation for development of fuzzy reasoning, *Proc. of ISMVL '87*, Boston, USA (IEEE Computer Society Press, New York), 1987, 326 - 335.
4. N. Cat Ho, A method in linguistic reasoning on a knowledge base representing by sentences with linguistic belief degree, *Fundamenta Informaticae* **28** (3,4) (1996), 247-259 (also appeared in "Linguistic-valued logic and a deductive method in linguistic reasoning", *Proc. of the Fifth IFSA'93*, Seoul, Korea, July 4-9, 1993, pp. 191-194).
5. N. Cat Ho, H. V. Nam, T. D. Khang, N. H. Chau, Hedge algebras, linguistic-valued logic and their application to fuzzy reasoning, *Inter. J. of Uncertainty, Fuzziness and Knowledge-Based Syst.* **7**(4) (1999) 347-361.

6. N. Cat Ho & H. Van Nam, A refinement structure of hedge algebras, *Proc. of the NCST of Vietnam* **9** (1) (1997) 15-28.
7. N. Cat Ho & H. Van Nam, A theory of refinement structure of hedge algebras and its application to fuzzy logic, in: D. Niwinski & M. Zawadowski, Eds., *Logic, Algebra and Computer Science*, Banach Center Publications **46** (1999) 63-91.
8. N. Cat Ho & W. Wechler, Hedge algebras: An algebraic approach to structure of sets of linguistic truth values, *Fuzzy Sets and Systems* **35** (1990) 281-293.
9. N. Cat Ho & W. Wechler, Extended hedge algebras and their application to fuzzy logic, *Fuzzy Sets and Systems* **52** (1992) 259 - 281.
10. R. Cignoli, F. Esteva, L. Godo, A. Torrens, Basic fuzzy logic is the logic of continuous t -norms and their residua, *Soft Computing* **4** (2000) 106-112.
11. D. Dubois & H. Prade, New trends and open problems in fuzzy logic and approximate reasoning, *Theoria* **11** (27) (1996) 109-121.
12. D. Dubois & H. Prade, Fuzzy sets in approximate reasoning, part Inference with possibility distributions, *Fuzzy Sets and Systems* **40** (1991) 143 - 202.
13. F. Esteva & L. Godo, Monoidal t -norm based Logic: Towards a logic for left-continuous t -norms, *Fuzzy Sets and Systems* (accepted).
14. F. Esteva., L. Godo, P. Hajek, M. Navara, Residuated fuzzy logic with an involutive negation, *Archive for Mathematical Logic* **39** (2000) 103-124.
15. F. Esteva, L. Godo, F. Montagna. $L_{\frac{1}{2}}$ and $L_{\frac{1}{2}1/2}$: two complete fuzzy logic systems joining Lukasiewicz and Product logics, *Archive for Mathematical Logic* **40** (2001) 39-67.
16. J. C. Fodor & T. Keresztfalvi, Non-standard conjunctions and implications in fuzzy logic, *Inter. J. of Approximate Reasoning* **12** (1995) 69 - 84.
17. R. Giles, Lukasiewicz logic and fuzzy set theory, *Inter. J. of Man-Machine stud.* **8** (1976) 313-327.
18. L. Godo & P. Hajek, On Deduction in Zadeh's Fuzzy Logic, *Proc. IPMU'96*, Granada (1996) 991 - 996.
19. L. Godo & P. Hajek, Fuzzy Inference as Deduction, *Journal of Applied non-Classical Logics* (Walter Carnielli, guest editor) **9** (1) (1999) 37-60.
20. S. Gottwald, Fuzzy propositional logics, *Fuzzy Sets and Systems* **3** (1980) 181-192.
21. P. Hajek, *Metamathematics of Fuzzy logic*, Kluwer, 1998.
22. P. Hajek, Fuzzy Logic and arithmetical hierarchy, *Fuzzy Sets and Systems* **73** (1995) 359 - 363.
23. P. Hajek, Fuzzy Logic from logical point of view, in *SOFSEM'95: Theory and Practice of Informatics*, LNCS **1012**, (M. Bartoseck, J. Standek and J. Wiedemann, Eds.), Springer - Verlag (1995), 31 - 49.
24. P. Hajek, Very true, *Fuzzy Sets and Systems* (to appear).
25. F. Klawonn & V. Novak, The relations between inference and interpolation in frame work of fuzzy systems, *Fuzzy Sets and Systems* **81** (1996) 336 - 354.
26. E. P. Klement, Some mathematical aspects of fuzzy sets: Triangular norms, fuzzy logics, and generalized measures,

27. G. Lakoff, Hedges: A study in meaning criteria and the logic of fuzzy concepts, *J. Philos. Logic* **2** (1973) 458-508 (also presented at the 8th Regional Meeting of the Chicago Linguistic Society, 1972).
28. M. Mizumoto, Comparison of various fuzzy reasoning methods, *Preprints of Second IFSA Congress*, Tokyo, July 20-25, 1987.
29. C. V. Negoita & D. A. Ralescu, *Application of Fuzzy Sets to System Analysis*, ISR Vol. **11** (Birkhauser, Basel-Boston, 1975).
30. V. Novak, Fuzzy control from logical point of view, *Fuzzy Sets and Systems* **66** (1994) 154 - 173.
31. H. Rasiowa, *An Algebraic Approach to Non-classical Logic* (North-Holland, Amsterdam-New York, 1974).
32. H. Rasiowa & R. Sikorski, *The Mathematics of Metamathematics*, second edition (Polish Scientific Publication, Warszawa, 1968).
33. D. B. Rinks, A heuristic approach to aggregate production scheduling using linguistic variables, *Proc. of Inter. Congr. on Appl. Systems Research and Cybernetics*, Vol. VI (1981) 2877-2883.
34. H. J. Skala, On many-valued logics, fuzzy sets, fuzzy logics and their applications, *Fuzzy Sets and Systems* **1** (1978) 129-149.
35. Y. Tsukamoto, An approach to fuzzy reasoning method, in M. M. Gupta, R. K. Ragade, R. R. Yager, Eds., *Advances in Fuzzy Set Theory and Applications* (North-Holland, Amsterdam, 1979) 137-149.
36. E. Turunen, BL-algebras of basic fuzzy logic, *Mathware & Soft Computing* **6** (1999) 49-61.
37. L. A. Zadeh, Fuzzy-set-theoretic interpretation of linguistic hedges, *J. of Cybernetics* **2** (1972) 4-34.
38. L. A. Zadeh, A theory of approximate reasoning, in: R. R. Yager, S. Ovchinnikov, R. M. Tong and H. T. Nguyen, Eds., *Fuzzy Sets and Applications: The selected papers by L. A. Zadeh* (Wiley, New York, 1987) 367-411.
39. L. A. Zadeh, The concept of linguistic variable and its application to approximate reasoning, *Inform. Sci.*, I: **8** (1975) 199-249; II: **8** (1975) 310 -357; III: **9** (1975) 43-80.
40. L. A. Zadeh, Fuzzy sets, usability and common-sense reasoning, in: L. M. Vaina (Ed.), *Matters of Intelligence*, (D. Reidel publishing company, 1987) 289-309.

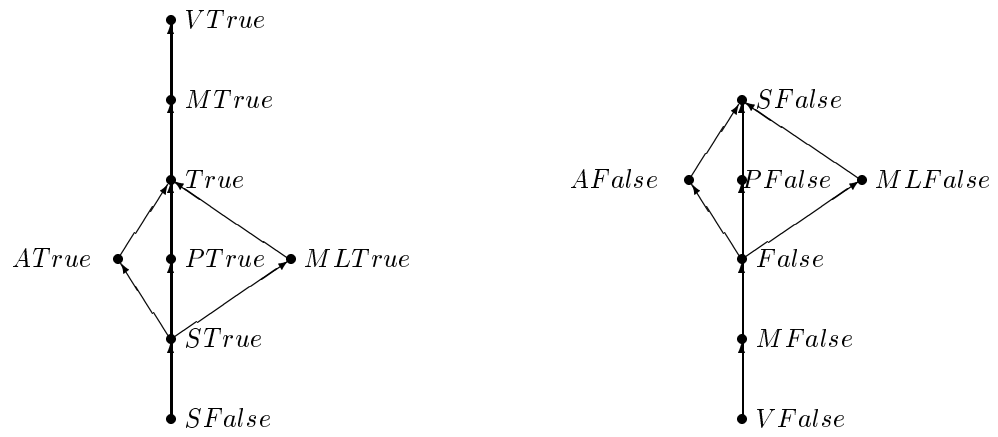

FIGURE 1. A poset of values of the linguistic variable *Truth*

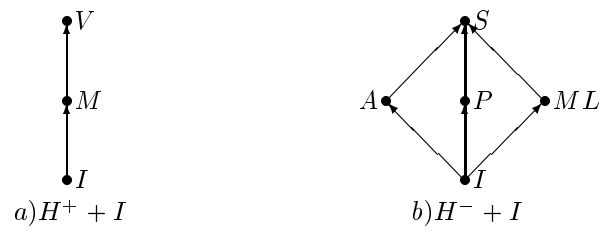

FIGURE 2. Lattices of hedges

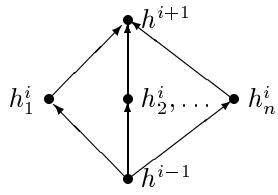

FIGURE 3. $H_{i-1}^+ < H_i^+ < H_{i+1}^+$

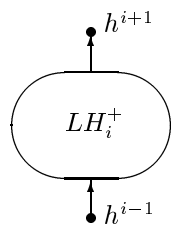
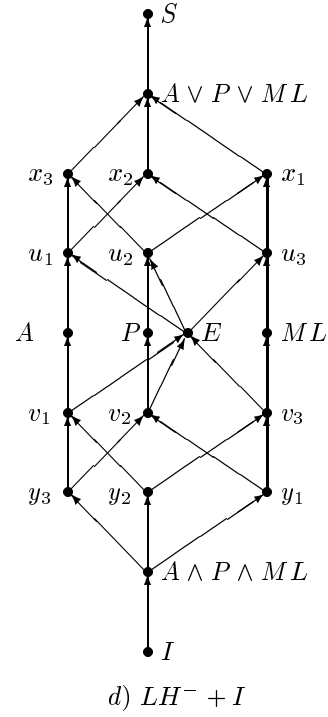
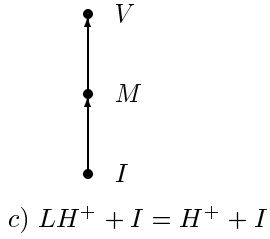
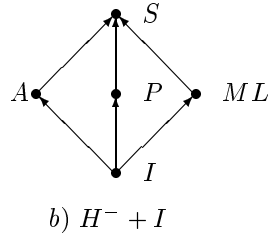
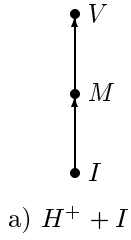

FIGURE 4. $LH_{i-1}^+ < LH_i^+ < LH_{i+1}^+$



where

$$\begin{aligned}
 x_1 &= P \vee ML; & x_2 &= ML \vee A; & x_3 &= A \vee P; & u_1 &= x_2 \wedge x_3; & u_2 &= x_3 \wedge x_1; & u_3 &= x_1 \wedge x_2; \\
 y_1 &= P \wedge ML; & y_2 &= ML \wedge A; & y_3 &= A \wedge P; & v_1 &= y_2 \vee y_3; & v_2 &= y_3 \vee y_1; & v_3 &= y_1 \vee y_2;
 \end{aligned}$$

and $E = (A \vee P) \wedge (P \vee ML) \wedge (ML \vee A) = (A \wedge P) \vee (P \wedge ML) \vee (ML \wedge A)$.

FIGURE 5. Lattices of hedges $H^c + I$ and 'freely' generated lattices $LH^c + I$.

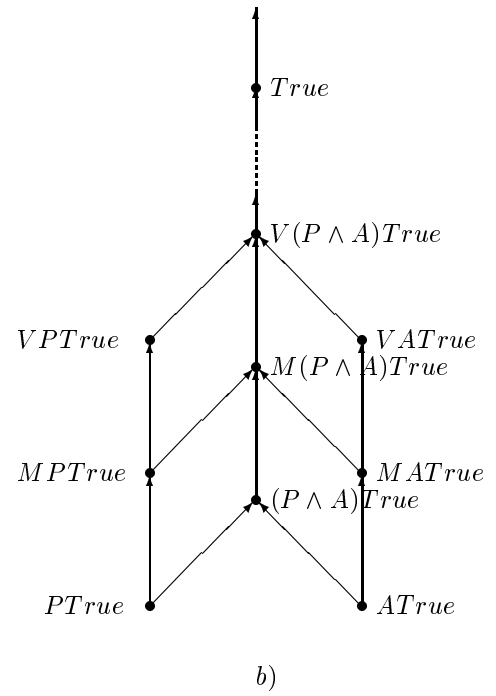
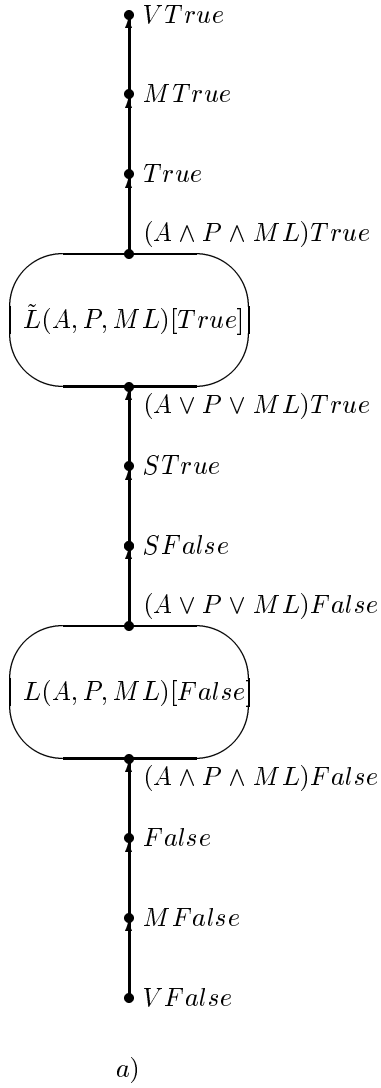

FIGURE 6. The poset of Example 3.1, where $\tilde{L}(A, P, ML)True$ denotes the dual of $L(A, P, ML)True$.

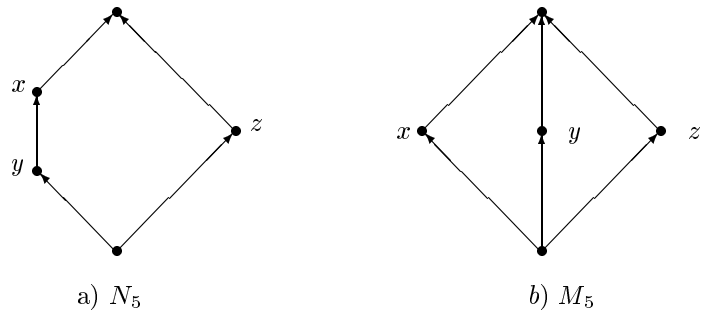

FIGURE 7. Lattices N_5 and M_5