

|              |  |
|--------------|--|
| Title        | Realistic performance evaluation for turbo diversity using field measurement data  |
| Author(s)    | Sarestoniemi, Mariella; Matsumoto, Tad; Kansanen, Kimmo; Schneider, Christian  |
| Citation     | ITG Workshop on Smart Antennas, 2004.: 138-143   |
| Issue Date   | 2004-03  |
| Type         | Conference Paper   |
| Text version | publisher  |
| URL          | <a href="http://hdl.handle.net/10119/9120">http://hdl.handle.net/10119/9120</a>  |
| Rights       | Copyright (C) 2004 IEEE. Reprinted from ITG Workshop on Smart Antennas, 2004, 138-143. This material is posted here with permission of the IEEE. Such permission of the IEEE does not in any way imply IEEE endorsement of any of JAIST's products or services. Internal or personal use of this material is permitted. However, permission to reprint/republish this material for advertising or promotional purposes or for creating new collective works for resale or redistribution must be obtained from the IEEE by writing to <a href="mailto:pubs-permissions@ieee.org">pubs-permissions@ieee.org</a> . By choosing to view this document, you agree to all provisions of the copyright laws protecting it. |
| Description  |  |

## REALISTIC PERFORMANCE EVALUATION FOR TURBO DIVERSITY USING FIELD MEASUREMENT DATA

Mariella Särestöniemi\*, Tad Matsumoto\*, Kimmo Kansanen\*, and Christian Schneider\*\*

\*University of Oulu, Center for Wireless Communications, P.O. Box 4500, FIN-90014, Oulu, Finland, {mariella, tadashi.matsumoto, kmo}@ee.oulu.fi

\*\*Ilmenau University of Technology, PSF 100565, D-98684 Ilmenau, Germany, christian.schneider@tu-ilmenau.de

**Abstract** – In turbo diversity technique, soft-cancellation followed by minimum mean squared error filtering (SC/MMSE) is applied to diversity combining of broadband single-carrier signals using multiple antennas in order to reduce the computational complexity. In this paper, our proposed turbo diversity technique is evaluated using field measurement data gathered in a suburban area in Germany. It is verified through the field measurement data –based simulations that the performance of the complexity-reduced turbo diversity technique can asymptotically achieve that of the original SC/MMSE equalizer.

### I. INTRODUCTION

The computational complexity for the equalization of the received signal corrupted by inter-symbol-interference (ISI) in single carrier systems increases exponentially with the equalizer's coverage when the maximum likelihood sequence estimation (MLSE) technique is used. Complexity-reduced iterative turbo techniques, soft canceller followed by MMSE filtering (SC/MMSE) [1]–[2], requires a cubic order complexity  $O(L^3M^3)$ , with  $L$  and  $M$  being the number of propagation paths and receive antennas, due to the matrix inversion needed for the MMSE filter coefficient calculation. To avoid the necessity of the matrix inversion, approximation techniques have been proposed in [3] and [4], by which the complexity can further be reduced.

The turbo diversity technique [5] reduces the complexity without approximating the SC/MMSE algorithm itself. The receiver antenna elements are split into a couple of branches in which the SC/MMSE signal processing is first performed independently. After sufficient SC/MMSE iterations, the obtained log likelihood ratios (LLR) are propagated cross-wise between the soft-input soft-output (SISO) channel decoders on the each group. Finally their bit-wise LLRs are combined for the final decision. It has been shown that turbo diversity performance approaches that of the original SC/MMSE equalizer [5].

The major objective of this paper is to verify the asymptotic performance tendency of the complexity-reduced turbo

diversity technique through field measurement data –based simulations. Multi-dimensional channel sounding field measurement campaign took place in Ilmenau, Germany. Channel impulse response data was gathered along the measurement route. The measurement data was pre-processed, of which process is comprised of upsampling, convolution with the transmitted waveform, and downsampling as well as delay-windowing to the adjusted bandwidth according to the system requirements. The pre-processed impulse response was then used in the off-line simulations.

This paper is organized as follows: Section II describes the communication channel model used. Section III summarizes the algorithm of the original SC/MMSE turbo equalizer. Section IV derives turbo diversity receiver configuration. Section V presents the measurement based simulation conditions and simulation results are shown and discussed in Section VI. Conclusions are given in Section VI.

### II. CHANNEL MODEL

We assume a single user single carrier signaling scenario. Let the transmitted symbol sequence be denoted by  $\underline{b}(k)$ . The sequence is transmitted using a single transmit antenna over frequency selective channels. The receiver is employed with  $M$  antennas. Space-time representation of the received signal vector  $\underline{y}(k)$  is expressed as

$$\underline{y}(k) = \underline{H} \cdot \underline{b}(k) + \underline{v}(k), \quad (1)$$

where

$$\underline{H} = \begin{bmatrix} H(0) & \dots & H(L-1) & & 0 \\ & \ddots & & \ddots & \\ 0 & & H(0) & \dots & H(L-1) \end{bmatrix} \quad (2)$$

is the channel matrix with

$$H(l) = [h_1(l) \ h_2(l) \ \dots \ h_M(l)]^T, \quad l = 0 \dots L-1 \quad (3)$$

and  $h_m(l)$  is a discrete time representation of the channel between the transmitter and the  $m$ th receiver antenna. The vector  $\underline{b}(k)$  is given by

This research is funded by National Technology Agency of Finland (TEKES), Nokia, Elektrobit and Finnish Air Force, which is gratefully acknowledged.

$$\underline{b}(k) = [b(k+L-1) \dots b(k) \dots b(k-L+1)]^T \quad (4)$$

and

$$\underline{V}(k) = [\underline{v}^T(k+L-1) \dots \underline{v}^T(k)]^T \quad (5)$$

with

$$\underline{v}(k) = [v_1(k) \ v_2(k) \ \dots \ v_M(k)]^T \quad (6)$$

is the Addition White Gaussian Noise (AWGN) vector.

### III. SC/MMSE TURBO EQUALIZER

Since the original SC/MMSE and its derivative algorithms are presented in a couple of references [1]-[4], this section only summarizes the algorithm.

A transmitter-receiver block diagram considered in the context of SC/MMSE turbo equalization is depicted in Figure 1. The SC/MMSE turbo equalizer consists of an SC/MMSE part and a soft-input soft-output (SISO) decoder part. The SC/MMSE part delivers the log-likelihood ratio (LLR) of each symbol in a frame. After de-interleaving the LLR values, SISO decoding is performed. The updated LLRs are fed back to the SC/MMSE part, which performs the SC/MMSE signal processing again. This process is repeated until the convergence of the performance is reached. Note that symbol-wise LLRs obtained from the SC/MMSE may have to be converted into bit-wise, depending on the decoder used. After decoding they have to be converted again into symbol-wise before feeding them back to the SC/MMSE part.

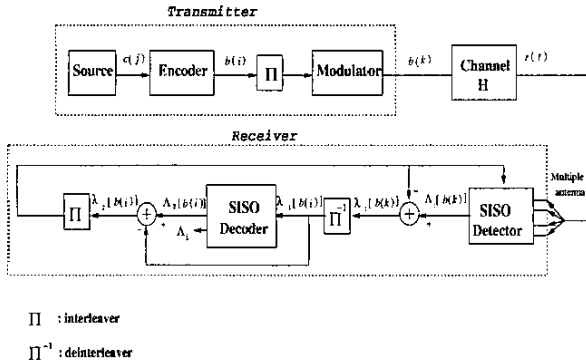

Figure 1. A transmitter-receiver block diagram in the context of SC/MMSE turbo equalization.

SC/MMSE requires output vector of the multiple antennas, the estimate of the channel matrix  $\underline{H}$ , and the soft symbol  $\hat{b}$  calculated from the LLR. Multiplying the channel matrix estimate  $\underline{H}$  by the soft symbol vector  $\underline{u}(k)$

$$\underline{u}(k) = [\hat{b}(k+L-1) \dots \hat{b}(k+1) \ 0 \ \hat{b}(k-1) \dots \hat{b}(k-L+1)] \quad (7)$$

the soft estimates of the interfering components can be calculated which are then subtracted from the antenna output vector as

$$\hat{\underline{y}}(k) = \underline{y}(k) - \underline{H} \cdot \underline{u}(k) \quad (8)$$

This process is referred to as soft cancellation.

The soft canceller output  $\hat{\underline{y}}(k)$  still has residual interfering components, which can further be suppressed by MMSE filtering. The MMSE filter also combines the multipath components. This iteration process is repeated resulting in the overall performance almost the same as the optimal receiver performance [1].

### IV. TURBO DIVERSITY BASED ON SC/MMSE

The computation of the MMSE filter coefficients requires inversion of the covariance matrix of the soft canceller output, of which the computational complexity is a cubic order  $O(L^3M^3)$  of  $LM$ . This leads to an idea that the multiple antenna elements are split into  $K$  diversity branches, in which the SC/MMSE signal processing first takes place independently. After sufficient SC/MMSE iterations, the SISO decoders of the each group are connected cross-wise to enable the exchange of the obtained LLRs between the decoders. Finally, the LLRs of the bits are combined, on which the final decision is made.

Figure 2 shows a block diagram of an example of the SC/MMSE turbo diversity receiver, in which four antenna elements are split into two branches. The SC/MMSE equalizers and SISO decoders are connected via two sets of switches  $\{S1a, S2a\}$  and  $\{S1b, S2b\}$ . For initial convergence the SC/MMSE iteration takes place independently on the two branches, i.e.,  $\{S1a, S2a\}$  are open, and  $\{S1b, S2b\}$  are closed. This process is referred to as horizontal iteration. After a sufficient number of horizontal iterations the obtained LLRs from the SC/MMSE parts,  $\lambda_1^1$  and  $\lambda_1^2$ , are stored, switches  $\{S1a, S2a\}$  closed, and  $\{S1b, S2b\}$  opened for vertical iterations.

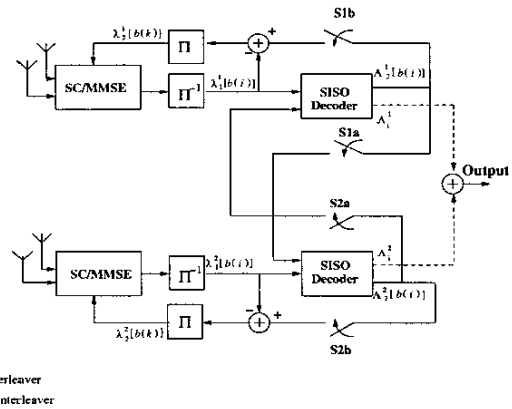

Figure 2. The structure of the single user SC/MMSE turbo diversity scheme.

During the vertical iterations, the LLR values are propagated between the SISO decoders. On the first branch,  $\Lambda_2^2 + \lambda_1^1$  is fed to the SISO decoder, which then provides the updated  $\Lambda_2^1$ , whereas on the second branch,  $\Lambda_2^2$  is updated by performing SISO decoding to the sum  $\Lambda_2^1 + \lambda_1^2$ . After the vertical iterations, the LLRs  $\Lambda_i^1$  and  $\Lambda_i^2$  of the bit estimates are combined, on which final decision is made.

The original SC/MMSE requires a cubic order of complexity  $O(L^3M^3)$ . If the  $M$  antenna elements are divided into  $K$  turbo diversity branches, the computational complexity becomes of the order  $O(L^3M^3/K^2)$ . Therefore, complexity reduction becomes more significant as  $K$  becomes larger.

### V. MEASUREMENT DATA

Multi-dimensional channel sounding measurement data, collected in Ilmenau, in a typical sub-urban area in Germany, and released by MEDAV in [6], was used. The place is hilly residential area where the average height of the buildings is 6m and the propagation is mostly non-line-of-sight. Figure 3 illustrates a map of the measurement route [6]. The transmitter has an omni-directional antenna, and the receiver antenna is 8 element uniform linear array (ULA) with element separation of 0.4 wavelength, and it is fixed to the point shown in Figure 3. The channel sounding signal bandwidth is 120 MHz, and carrier-frequency 5.2 GHz.

The raw data was preprocessed to reduce the bandwidth to 11 MHz, of which the obtained response was convoluted with a roll-off factor 0.25 raised cosine filter with upsampling rate 2. After downsampling, a segment of the processed impulse response was taken out within a calculated delay window. The obtained bandwidth-reduced impulse response was used in the simulations conducted to compare the performance of the original SC/MMSE and the turbo diversity SC/MMSE in a single user scenario.

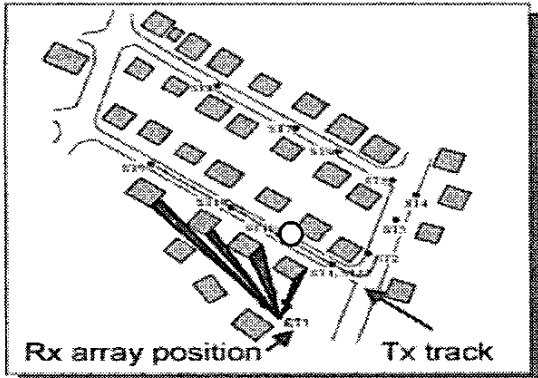

Figure 3: Map from the measurement route. [6]

### VI. PERFORMANCE RESULTS

It is shown in [5] that the performance of the turbo diversity equalizer approaches that of the original SC/MMSE as SNR increases. The primary purpose of this paper is to verify the performance tendency in real fields. The simulation parameters are summarized in Table I.

Table I. Simulation Parameters

|   |   |
|---|---|
| Modulation                              | BPSK  |
| Information bits/frame                  | 256   |
| Number of transmitted frames            | 10 / (BER exponent)                                       |
| Information bits                        | 256   |
| Channel coding                          | Convolutional coding (code rate=1/2, constraint length=3) |
| Interleaver                             | Random  |
| Channel estimation                      | Perfect   |
| Number of transmitter antennas ( $N$ )  | 1   |
| Number of receiver antennas ( $M$ )     | Original SC/MMSE=4<br>Turbo diversity=2+2                 |
| Number of branches ( $K$ )              | 2   |
| Number of horizontal iterations ( $H$ ) | 4   |
| Number of vertical iterations ( $V$ )   | 1   |
| Number of equalizer taps                | 7   |

First of all, performances of the original SC/MMSE and the turbo diversity scheme were verified in the area marked by a circle close to the point ST11 in the map of Figure 3. This is considered as a “good case” since the strong single bounce reflection can be observed via the house fronts. The BER performances at this point are shown in Figure 4. It is found that in this case both receivers achieve very good performance even at low SNR. It can be verified that the performance of the turbo diversity equalizer asymptotically approaches that of the original SC/MMSE

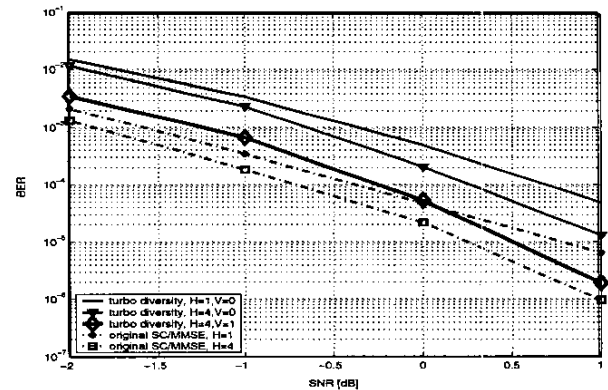

Figure 4. Original SC/MMSE and turbo diversity performances in snapshots from the area marked as a circle.

Next, BER performances were evaluated for a set of snapshots selected along the measurement route from ST9 to ST12 shown in Figure 3. The SNR was chosen to be 1 dB. BER performances of the turbo diversity equalizer and the original SC/MMSE after the last iterations for each of the selected snapshots are shown in Figures 5 and 6, respectively. Also the RMS delay spreads of the channels are marked by 'X' in the figures. From the figures it is found that the BER performance of the turbo diversity is significantly sensitive to the channel characteristics compared with the original SC/MMSE. Turbo diversity performance may vary even  $10e-4$  in BER from a snapshot to another, whereas the original SC/MMSE varies less than  $10e-2$  in BER.

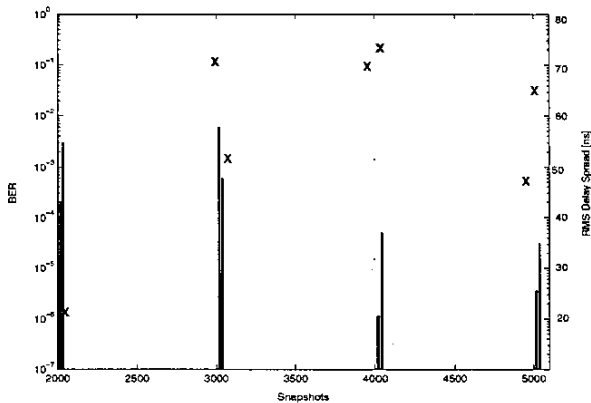

Figure 5. BER performances of the turbo diversity scheme for the selected snapshots with their delay spreads.

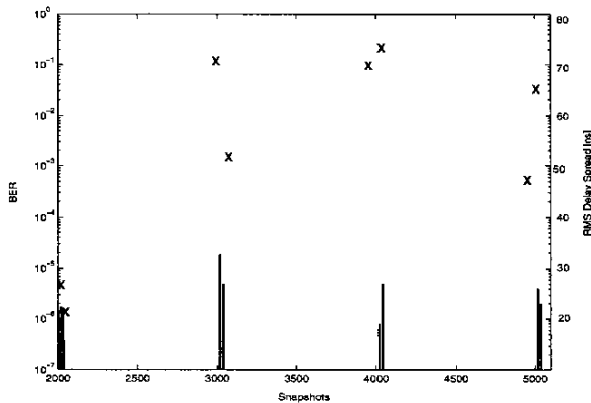

Figure 6. BER performances of the original SC/MMSE for the selected snapshots with their delay spreads.

To understand this performance tendency, the impulse responses of a "good snapshot" (4018) and a "bad snapshot" (3018) were observed, as well as the snapshot (2000), in which the original SC/MMSE achieves good performance whereas the performance of the turbo diversity scheme is poor.

Figure 7 illustrates impulse responses for the good snapshot (4018). Impulse responses received by first and second branches are separated by solid and dashed lines, respectively. It can be seen that the channel is in the minimum-phase mode and there is no timing-offset in the peaks of the impulse responses. There is relatively small power balance difference between the branches

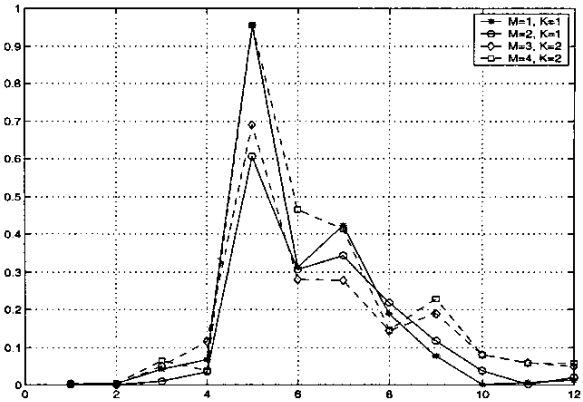

Figure 7. Impulse responses for the "good" snapshot (4018).

The impulse responses for the "bad" snapshot (3018) are shown in Figure 8. In this case the channel is not in the minimum-phase mode, which affects on the performance since the SC/MMSE works as a linear equalizer in the first iteration and 7 equalizer taps are not enough to mitigate the ISI when the equivalent diversity order of the SC/MMSE processing is smaller. Another point is that there is also some timing-offset between the peaks of the impulse responses. Furthermore the power balance difference between the antenna branches is larger than that of the snapshot 4018. These channel characteristics seem to affect more for the turbo diversity scheme than to the original SC/MMSE, most probably due to the smaller diversity order in the SC/MMSE processing.

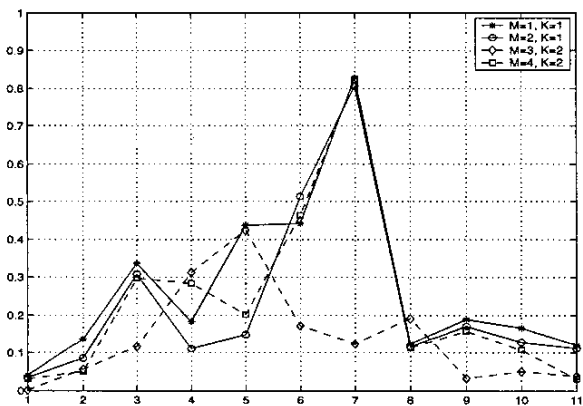

Figure 8. Impulse responses for the "bad" snapshot (3018).

In Figure 9 the impulse response of the snapshot (2000) is shown. Also in this case the channel is not in the minimum-phase mode. Besides, there is some timing-offset and power balance difference between the antenna branches.

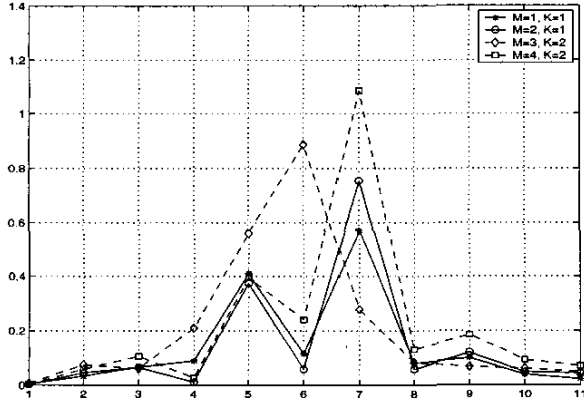

Figure 9. Impulse responses for the snapshot (2000).

These characteristics were common also to other snapshots, on which the performance of the turbo diversity scheme was relatively poor. Evidently these channels were clearly in non-minimum-phase mode. Then, the idea is that if the time is run reversely for these channels, they then become minimum-phase mode. To identify the effect of non-minimum-phase mode on the turbo diversity performance, simulations were conducted by using time-reversed channel impulse responses of the snapshots (3018) and (2000). Exceptionally two vertical iterations were performed in order to verify the effect of the LLR exchange between the branches.

Figure 10 shows turbo diversity performance in the snapshot (3018) when the time-reversal is performed. BER performance without time-reversal is also included for the comparison. It is noted that when the time-reversal is performed on the channel, the performance is improved significantly. Performance improvement can also be seen with the snapshot (2000), as shown in Figure 11. In this case the improvement is even more remarkable.

For both of the snapshots, BERs were also evaluated on the first and second turbo diversity branches based on their LLRs before combining. The performance of the first branch is found to be significantly worse than that of the second branch, especially with the snapshot (2000). However, it is improved notably after the vertical iteration due to the effect of the “better” LLRs received from the second branch. Apparently the BER of the second branch is not improved by the vertical iteration due to the “worse” LLRs of the first branch.

Finally, the simulations were conducted to the original SC/MMSE with time-reversed channel. From the performance comparison in Figure 12 it can be seen that in this case time-reversal does not have effect on the performance at higher iterations.

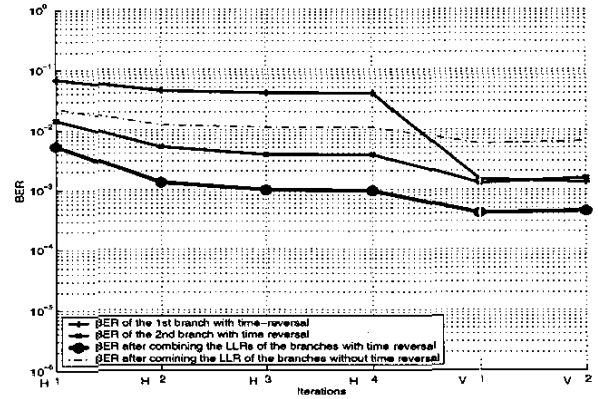

Figure 10. Turbo Diversity BER performances of the snapshot (3018) after time-reversal compared to the BER without time-reversal.

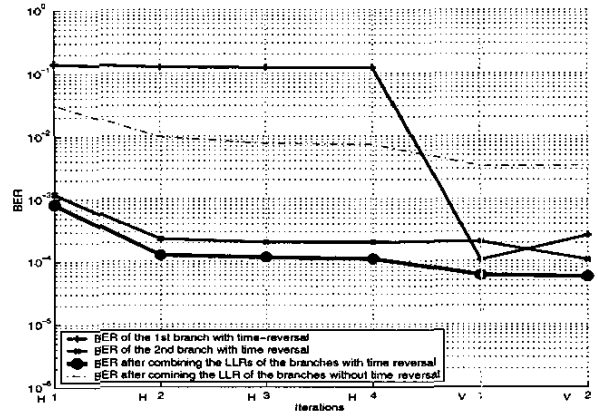

Figure 11. Turbo diversity BER performances of the snapshot (2000) after time-reversal compared to the BER without time-reversal.

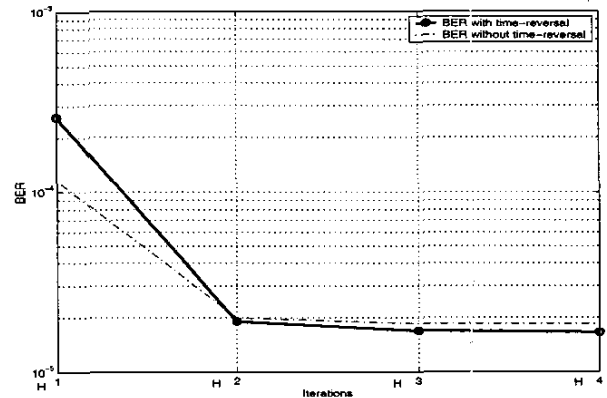

Figure 12. Original SC/MMSE BER performance of the snapshot (3018) after time-reversal compared to the BER without time-reversal.

These comparisons described above let us to conclude that the turbo diversity scheme can achieve very good performance in the cases where the channel is in minimum-phase mode. However, in other conditions the equalizer length of 7 is not enough to mitigate the effect of ISI due to the non-minimum-phase mode since the diversity order in the pure SC/MMSE signal processing is not large enough.

## VII. CONCLUSIONS

In this paper the performance of the complexity-reduced SC/MMSE turbo diversity scheme is evaluated by using field measurement data. It was shown that the performance of the original SC/MMSE is asymptotically approached by the turbo diversity scheme in the cases where the channel is in minimum-phase mode. However, given the same antenna configuration, when the channel is not in minimum-phase mode, the performance of the original SC/MMSE has better performance due to the higher diversity order with pure SC/MMSE processing than turbo diversity.

## REFERENCES

- [1] D. Reynolds and X. Wang, "Low-complexity Turbo Equalization for Diversity Channels", *Signal Processing*, Elsevier Science Publishers, Vol. 81, No. 5, May 2000, pp. 989-995.
- [2] M. Tuchler, R. Koetter, and A.C. Singer, "Turbo Equalization: Principle and New Results", *IEEE Trans. COM.*, Vol. 50, No. 50, May 2002, pp. 754-767
- [3] H. Oomori, T. Asai, and T. Matsumoto, "A Matched Filter Approximation for SC/MMSE Turbo Equalizers", *IEEE Communication Letter* 5, 2001, pp. 310-312.
- [4] K. Kansanen and T. Matsumoto, "A Computationally Efficient MIMO Turbo-Equalizer", *IEEE Vehicular Technology Conference*, Jeju, Korea, 2003
- [5] M. Särestöniemi, T. Matsumoto, and K. Kansanen, "A Turbo Diversity Technique based on SC/MMSE Equalizer", *Proc. IST Mobile Wireless Communication Summit*, Vol 2, pp. 411-413, Aveiro, Portugal.
- [6] MEDAV, Channel Sounder Data, URL: [www.channelsouder.de](http://www.channelsouder.de)