

Title	A joint spatial and temporal equalizer using separated spatial and temporal signal processing for broadband mobile radio communications
Author(s)	Tomisato, Shigeru; Matsumoto, Tadashi
Citation	2001 IEEE Third Workshop on Signal Processing Advances in Wireless Communications (SPAWC '01): 298-301
Issue Date	2001
Type	Conference Paper
Text version	publisher
URL	<a href="http://hdl.handle.net/10119/9128">http://hdl.handle.net/10119/9128</a>
Rights	Copyright (C) 2001 IEEE. Reprinted from 2001 IEEE Third Workshop on Signal Processing Advances in Wireless Communications (SPAWC '01), 2001, 298-301. This material is posted here with permission of the IEEE. Such permission of the IEEE does not in any way imply IEEE endorsement of any of JAIST's products or services. Internal or personal use of this material is permitted. However, permission to reprint/republish this material for advertising or promotional purposes or for creating new collective works for resale or redistribution must be obtained from the IEEE by writing to <a href="mailto:pubs-permissions@ieee.org">pubs-permissions@ieee.org</a> . By choosing to view this document, you agree to all provisions of the copyright laws protecting it.
Description	

# A Joint Spatial and Temporal Equalizer Using Separated Spatial and Temporal Signal Processing for Broadband Mobile Radio Communications

Shigeru Tomisato\*, and Tadashi Matsumoto\*,  
 \*Wireless Laboratories, NTT DoCoMo, Inc.  
 3-5 Hikarinooka, Yokosuka-shi, Kanagawa, 239-8536, Japan  
 E-mail: tomisato@mlab.yrp.nttdocomo.co.jp

**Abstract** — Joint spatial and temporal equalization techniques are considered most effective in reducing effects of Co-channel Interference (CCI) and Inter-Symbol Interference (ISI) in broadband mobile communications. This paper proposes a new configuration of Spatial and Temporal Equalizer (S/T-Equalizer) using separated spatial and temporal signal processing. An iterative parameter estimation technique is also proposed for the S/T-Equalizer. Computer simulations were conducted to demonstrate effectiveness of the proposed S/T-Equalizer. Results of computer simulations show that the proposed S/T-Equalizer can achieve excellent performances in the presence of CCI and ISI.

## I. INTRODUCTION

In mobile multimedia communications, Co-channel Interference (CCI) and Inter-Symbol Interference (ISI) are major problems to overcome. Joint space and time equalizers (S/T-Equalizers) are considered most effective in solving the problems [1][2]. S/T-Equalizer combines concepts of Adaptive Array Antenna (AAA) and Temporal Equalizer (TE). AAA aims to suppress CCI, and TE aims to reduce ISI effects. Among various types of TEs, Maximum Likelihood Sequence Estimation (MLSE) equalizer is known to achieve optimal performance [3]. Unfortunately, however, performances of the MLSE equalizers are sensitive to recovered symbol timing offset [4]. A solution to this problem is to use a fractionally-spaced Feed Forward Filter (FFF) before the temporal equalization. Obviously, optimal performances can be achieved with an S/T-Equalizer configuration expressed as a cascaded connection of AAA and MLSE equalizer where, as shown Fig. 1, each of the antenna elements is equipped with fractionally-spaced FFF [4]. However, the optimal S/T-Equalizer is too complex to implement because the total number of taps that have to be adaptively updated is  $LM+N$  where  $L$  is the number of antenna elements,  $M$  the number of FFF taps, and  $N$  the number of TE taps. Hence, a technique that can significantly reduce the complexity is required.

This paper proposes a new configuration of S/T-Equalizer using separated spatial and temporal signal processing. In this S/T-Equalizer configuration, a fractionally spaced FFF is inserted between AAA and MLSE equalizer.

Signal processing for the updating of FFF taps and AAA taps can be performed separately each other. The number of the adaptive taps is  $L+M+N$  with this configuration, thereby, signal processing complexity remains within a practical level. Obviously, however, the S/T-Equalizer with separated signal processing cannot achieve the optimal performance. This paper then proposes an iterative parameter estimation technique that can recover the performance loss. This paper first describes configuration of the proposed S/T-Equalizer with separated signal processing. A new algorithm that can perform an iterative parameter estimation is also presented. Results of computer simulations conducted to evaluate performances of the S/T-Equalizer are then presented.

## II. CONFIGURATION OF S/T-EQUALIZER

Fig. 2 shows a block diagram of the proposed S/T-Equalizer. The S/T-Equalizer consists of AAA, TE, and fractionally-spaced FFF. Instead of MLSE equalizer, Delayed Decision Feedback Sequence Estimation (DDFSE) equalizer [5] may be used as TE to reduce the computational complexity. The S/T-Equalizer has two parameter estimators that are used for separated spatial and temporal signal processing.

Parameter Estimator 1 (PE-1) first estimates the weight vectors with the AAA and TE using a training symbol sequence. During this period of time, FFF simply passes the AAA output signals (See Fig. 3 (a)).

Output  $y_a(i)$  of the  $L$ -element AAA is given by

$$y_a(i) = \mathbf{W}_a^H(i)\mathbf{R}(i), \quad (1)$$

where  $\mathbf{W}_a(i)$  and  $\mathbf{R}(i)$  are the weight and the sampled received signal vectors of AAA, respectively, with  $i$  being the symbol timing index. Let  $\mathbf{W}_a(i)$  and  $\mathbf{R}(i)$  be denoted by

$$\mathbf{R}(i) = [r_1(i), r_2(i), \dots, r_L(i)]^T \quad (2)$$

and

$$\mathbf{W}_a(i) = [w_{a1}, w_{a2}, \dots, w_{aL}]^T \quad (3)$$

respectively, where  $r_l(i)$  is the sampled signal received by the  $l$ -th element, and  $w_{al}(i)$  is the weight for the  $l$ -th element. The AAA output  $y_a(i)$  is then input to the TE

having  $M$ -taps. In the TE, a replica signal  $y_e(i)$  for its input  $y_a(i)$  is generated.  $y_e(i)$  can be expressed as

$$y_e(i) = \mathbf{W}_e(i)^H \mathbf{A}(i), \quad (4)$$

where  $\mathbf{W}_e(i)$  and  $\mathbf{A}(i)$  are the weight and the reference signal vectors for the TE, respectively. Let  $\mathbf{W}_e(i)$  and  $\mathbf{A}(i)$  be denoted by

$$\mathbf{A}(i) = [a_1(i), a_2(i), \dots, a_M(i)]^T \quad (5)$$

and

$$\mathbf{W}_e(i) = [w_{e1}(i), w_{e2}(i), \dots, w_{eM}(i)]^T, \quad (6)$$

respectively, where  $a_m(i)$  is the reference signal input to the  $m$ -th tap, and  $w_{em}(i)$  is the weight for the  $m$ -th tap. Estimation error  $e_1(i)$  is given by

$$e_1(i) = y_a(i) - y_e(i). \quad (7)$$

PE-1 updates the tap weight vectors  $\mathbf{W}_a(i)$  and  $\mathbf{W}_e(i)$  for the AAA and TE based on the minimum mean square error (MMSE) criterion that minimizes  $\langle |e_1(i)|^2 \rangle$ . The recursive least square (RLS) algorithm may be used for the tap updating.

Parameter Estimator 2 (PE-2) then estimates the weight vectors with the FFF and TE. During this period of time, the AAA weights determined as a result of the adaptation process for AAA and TE are used, and kept fixed. (See Fig. 3 (b)).

Output  $y_f(i)$  of the  $N$ -tap FFF is given by

$$y_f(i) = \mathbf{W}_f(i)^H \mathbf{C}(i), \quad (8)$$

where  $\mathbf{W}_f(i)$  and  $\mathbf{C}(i)$  are tap weight vector and input signal vector for the FFF. Let  $\mathbf{W}_f(i)$  and  $\mathbf{C}(i)$  be denoted by

$$\mathbf{C}(i) = [c_1(i), c_2(i), \dots, c_N(i)]^T \quad (9)$$

and

$$\mathbf{W}_f(i) = [w_{f1}(i), w_{f2}(i), \dots, w_{fN}(i)]^T, \quad (10)$$

relatively, where  $w_{fn}(i)$  is the input to the  $n$ -th tap, and  $c_n(i)$  is the weight for the  $n$ -th tap. The FFF output  $y_f(i)$  is the input to the TE, where a replica signal  $y_e(i)$  for the TE input  $y_f(i)$  is generated.  $y_e(i)$  is given by Eq. (4). Estimation error  $e_2(i)$  is given by

$$e_2(i) = y_f(i) - y_e(i) \quad (11)$$

PE-2 updates the tap weight vectors  $\mathbf{W}_f(i)$  and  $\mathbf{W}_e(i)$  for the FFF and TE based on the MMSE criterion that minimizes  $\langle |e_2(i)|^2 \rangle$ .

As shown in Fig.4, Iterative parameter estimation performs the two-step weight updating process repeatedly until all the taps with AAA, FFF, and TE converge. The FFF taps are fixed while the taps with AAA and TE are being updated, and the AAA taps are fixed while the taps with the FFF and TE are being updated.

### III. TRANSMISSION PERFORMANCE

Computer simulations were conducted to evaluate performances of the proposed S/T-Equalizer. Table 1 shows simulation conditions. A DDFSE equalizer was used as a temporal equalizer. Fig. 4 illustrates an example of the beam patterns obtained by the proposed S/T-Equalizer under a multipath fading condition, where, as shown in Table 1, one desired and one interference users, each having three propagation paths, are assumed. Dashed line represents the beam pattern obtained under a static condition. It is found from Fig. 4 that the proposed S/T-Equalizer can properly steer nulls towards the directions of interference paths, although the nulls are not as deep as those formed under the static condition.

Fig. 5 shows BER performance of the proposed S/T-Equalizer. Dashed line represents BER performance obtained by setting the AAA taps at those obtained under a static condition. (This scheme is referred to as "pre-set AAA tap" scheme for convenience.) Difference in Eb/No values to achieve BER=10<sup>-3</sup> between the S/T-Equalizer with the pre-set AAA taps and proposed algorithm is less than 2dB.

Fig. 6 shows the BER performance of the proposed S/T-Equalizer with iterative parameter estimation with the number of the training symbols and the iteration times as parameters. Dashed lines represent BER performance curves without iterative parameter estimation. Results show that BER with iterative parameter estimation is almost equivalent to that using pre-set AAA taps generated under the static condition. The proposed S/T-Equalizer with iterative parameter estimation can obtain roughly 2 dB improvement over without iterative parameter estimation using the same length of the training symbol sequence.

### IV. CONCLUSION

This paper has proposed a new S/T-Equalizer configuration for broadband mobile signal transmission. Instead of having FFF on each AAA element, FFF is inserted between AAA and TE. With the proposed configuration, signal processing for AAA and TE tap updating can be performed separately from FFF and TE tap updating, thereby required computational complexity can be significantly reduced. An iterative parameter estimation technique has also been proposed. BER performance of the proposed S/T-Equalizer with the iterative parameter estimation is found to be almost equivalent to that with the S/T-Equalizer having pre-set AAA taps.

### REFERENCES

- [1] W. Modestio and V. Eyboglu, "Integrated multielement receiver structures for spatially distributed interference channels," IEEE Trans. IT, vol. IT-32, No.2, pp.195-219, Mar. 1986.
- [2] R. Kohno, "Spatial and Temporal Communication Theory Using Adaptive Antenna Array," IEEE Personal Communications, pp.28-35, Feb. 1998.

- [3] K. Fukawa and H. Suzuki, "Adaptive equalization with RLS-MLSE for frequency selective fast fading mobile radio channels," IEEE GCOM '91, Phoenix, pp.16.6.1-16.6.5, Dec. 1991.
- [4] K. Fukawa and T. Matsumoto, "A New Joint Array Signal Processing Structure and Maximum Likelihood Sequence Estimation in Mobile Radio Communications," Smart Antenna Workshop '97, 1997.
- [5] A. Duel-Hallen and C. Heegard, "Delayed Decision-Feedback Sequence Estimation," IEEE Trans. Commun., vol.37, No.5, pp.428-436, May 1989.

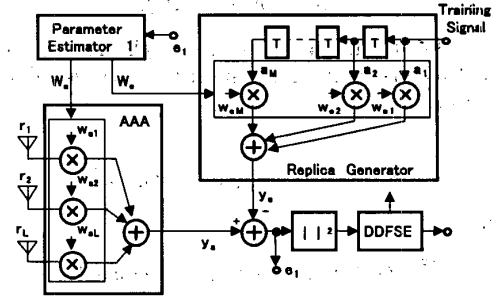

(a) Signal Processing of PE-1

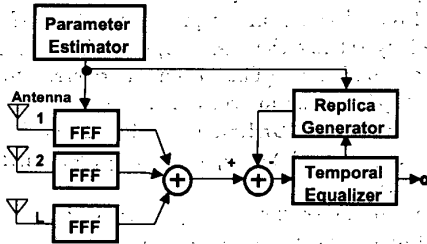
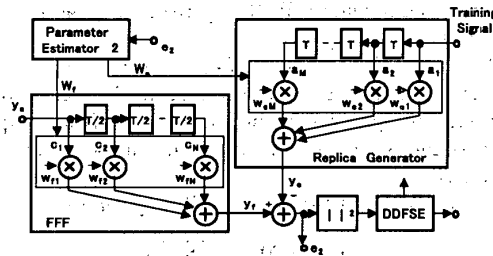

Fig. 1: Optimal S/T-Equalizer



(b) Signal Processing of PE-2

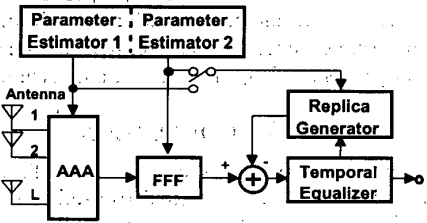

Fig. 2: Proposed S/T-Equalizer

Fig. 3: Signal Processing of Proposed S/T-Equalizer

Table 1: Simulation Conditions	
Modulation	QPSK
AAA	8 elements, Circular Array
T-Equalizer, FFF	16 state DDFSE(5 taps), 0.5 T spaced
Adaptive Algorithm	RLS
Frame Format	Training: 32 symbols, Data: 128 symbols
Interference Number	1
Path Number (Delay)	3 (0, 1T, 10T)
DOA	D: 0 deg., 60 deg., 120 deg. U: 30 deg., 90 deg., 150 deg.

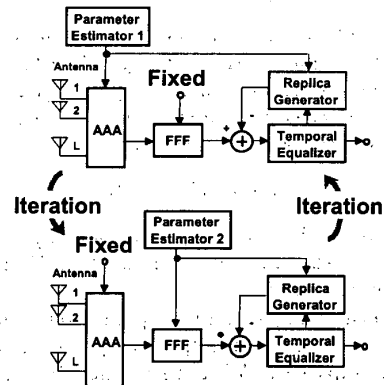

Fig. 4: Proposed Iterative S/T-Equalizer

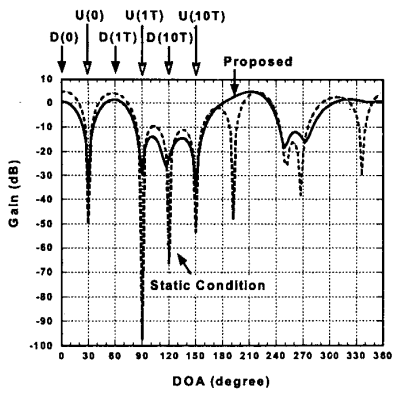

Fig. 5: Beam Pattern of Proposed S/T-Equalizer

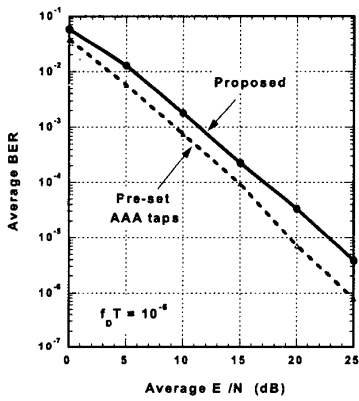

Fig. 6: BER Performance of Proposed S/T-Equalizer

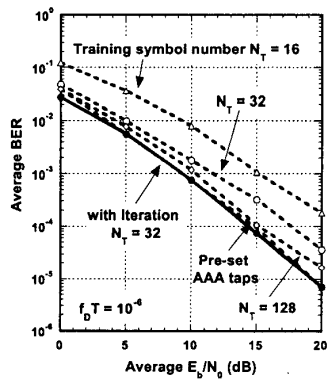

Fig. 7: BER Performance with Iteration